



SUPER·CLEAN
超洁亮

2026

产品目录 PRODUCT CATALOG

清洁机械 / 清洁工具 / 酒店用品 / 清洁剂
Cleaning Machine / Cleaning Tool / Hotel Supplies / General Detergent



广州市超洁亮清洁机械有限公司
GUANGZHOU SUPER CLEAN MACHINERY CO.,LTD

ISSA MEMBER
Advancing clean. Driving innovation.
美国国际清洁卫生协会会员



SUPER·CLEAN
超洁亮

要选好质量，还是超洁亮



关注微信公众号

国内销售部 Domestic sales Department

总机 Tel: 020-86063388 86060088

传真 Fax: 020-86063638

邮编 P.C.: 510460

邮箱 E-mail: superclean@super-clean.com.cn

出口销售部 Export Department

总机 Tel: +86-20-86060266

传真 Fax: +86-20-86061828

邮编 P.C.: 510460

官网 website: www.super-clean.com.cn

广州市超洁亮清洁机械有限公司
Guangzhou Super Clean Machinery CO.,LTD

地址: 广州市白云区江高镇神山工业园振中北路13号
Add: 13# North of zhenzhong Road, Shenshan Industrial Zone,
JiangGao Town, Baiyun District, Guangzhou, China.



邦启湘 | 公司董事长 兼总经理

浩瀚商海，英豪倍出。在市场竞争日益激烈的行业中，优秀企业将会获得更大的发展空间。超洁亮清洁机械正是在这大环境里茁壮成长的企业。我们将凭现有的品牌优势，产品优势，在清洁机械领域先人一步，加快企业发展的步伐，不断提升企业的实力。

精雕细作，我们脚踏实地；胸怀天下，我们志存高远。立足广东，辐射全中国，放眼全世界。面对未来，我们只有一个目标：通过自身的实力和对人类的贡献，用“诚信和品质”塑造中国清洁机械制造业的卓越品牌，让超洁亮的品牌享誉国际。我们深信，超洁亮成熟的发展势头，将会以更加稳健的步伐，以时不待我的紧迫感，舍我其谁的使命感带领清洁用品产业跨步前进。

秉持诚信、开放理念，我公司愿与您携手共进，共创更加灿烂辉煌的明天。



企业简介

广州市超洁亮清洁机械有限公司前身始创于一九八八年，是集技术研发、生产、销售于一体的企业。公司研发生产销售洗地机系列产品、吸尘吸水机、吹风机、蒸汽机、地毯抽洗机、清洁工具、客房用品、清洁剂等系列产品，现拥有超洁亮、驰丽洁、劲霸、钊隆、海亮、亮洁、深海洁等七大自主品牌。

公司位于美丽的广州市白云区神山镇工业园内，占地面积约5万平方米，建筑面积约12万平方米，经过三十多年的发展，目前销售网络已经覆盖国内所有大、中、小城市，并远销国外一百多个国家和地区，广泛用于机场、高铁、地铁、大型工厂、宾馆酒店、写字楼等场所，并被广大用户所推崇。

公司秉持“创新是发展、质量是生命、信誉是保证、顾客是上帝”的企业精神，以专业的研发生产管理技术队伍及现代化的生产设备，不断研发生产具有领先地位的新产品，不断地完善服务体系，让我们的企业成为现代清洁行业的领导者！

要选好质量，还是超洁亮！

充满朝气和活力的超洁亮人正朝着企业的最终目标不断奋斗！

广州市超洁亮清洁机械有限公司愿与您共赢当下，共创明天！

超洁亮二厂
The second factory of Super-Clean



ENTERPRISE PROFILE

The predecessor of Guangzhou Super Clean Machinery CO.,LTD was initially founded in 1988, which was an enterprise integrating technology research and development, production and selling. The company now develops, produces and sells scrubber series products, vacuum cleaner, blower, steam machine carpet machine, cleaning tools, guestroom equipments, cleanser and so on, possessing seven self-owned brands of Super-clean, Run Speed, Kimbo, ZhaoLong, Hai light, Light clean and Sea clean.

The company is located in the beautiful Shenshan town industrial park of Guangzhou Baiyun District, with the floor space of about 50,000 square meters and building area of about 120,000 square meters. After 38 years' development, now its selling network has covered all the large, medium and small cities in domestic, and the products have found a good sale in more than one hundred countries overseas. The products are widely applied to airports, high-speed rails, metro, large factories, hotels, office buildings, etc, and highly praised by customers.

It insists on the enterprise spirit of "Innovation is development, quality is life, reputation is guarantee and customer is God", continually develops and produces new products of leading position with the specialized Development, Production, Management and Technical Team and the modernized production equipments, and continually improves the service system, enabling our company to be the leader of modern cleaning industry!

Our object: Super clean, Super quality !
Our colleagues with vitality and vigor are continuously striving for our ultimate goal!
Guangzhou Super Clean Machinery CO., LTD is willing to seize today and create tomorrow with you!



团队协作 | TEAM COOPERATION

挑战自我 | CHALLENGE SELF

超洁亮人一直保持着对前沿技术与精致品质的最高追求，我们不畏艰险，艰苦卓绝。正是这种追求，在充满竞争和挑战的市场环境中，推动我们勇往直前。

Super Clean have been maintained the highest pursuit of cutting-edge technology and exquisite quality, We take the bull by the horns, extremely hard and bitter. It is this pursuit, in a market environment full of competition and challenges, to promote our courage.

团队协作 | TEAM COOPERATION

团队合作往往能激发出团体不可思议的潜力，集体协作干出的成果往往能超过成员个人业绩的总和。正所谓“同心山成玉，协力土变金”。一个团体，如果组织涣散，人心浮动，人人自行其是，何来生机与活力？又何谈干事创业？在一个缺乏凝聚力的环境里，个人再有雄心壮志，再有聪明才智，也不可能得到充分发挥！只有严密有序的集体组织和高效的团队协作，懂得团结协作克服重重困难，甚至创造奇迹。小溪只能泛起破碎的浪花，百川纳海才能激发惊涛骇浪，个人与团队关系就如小溪与大海。每个人都要将自己融入集体，才能充分发挥个人的作用。总之，团队精神对任何一个组织来讲都是不可缺少的精髓。否则就如同一盘散沙，一根筷子容易弯，十根筷子折不断……也是团队精神重要之所在。

The team are often able to inspire unbelievable potential group, the total collective collaboration of the results do tend group, if well organized, popular feeling drifts, everyone go one's own way, how can the vitality and the vigor? How about entrepreneurship? A lack of cohesion of the environment, people have lofty ideals and high aspirations, and one's ability and cleverness, can not be given full play! Only strict and orderly collective organization and efficient teamwork, unity cooperation to overcome difficulties, or even create a miracle. Streams can only be broken waves, sea rivers can stimulate the tempestuous waves, personal relationship with the team as streams and the sea. Everyone will be their integration into the collective, to give full play to the role of the individual. In short, the team spirit is indispensable to any organisation essence. Otherwise just as lacking spirit of cooperation; A chopstick is easy to bend, ten chopsticks break…… This is the team spirit importance intuitive strength of the performance, this is also my understanding of teamwork, team spirit is also important in.

综合清洁解决方案

优质产品支持 | 系统售后服务 | 免费来厂培训

Comprehensive Cleaning Solution For You

FOR YOU

我们为您提供高质量的商品、优质的服务和系统的售后

Super Clean is always providing high quality products.

Our service system is perfect and efficient.

超洁亮欢迎世界各地优质经销商加入我们的团队

If you wants to join us to be our Distributor, we can make you a firm partner.

真诚邀请您来厂参观、考察、学习

Welcome to visit our company and thanks for attention to our products.



SUPER·CLEAN

超洁亮

要选好质量，还是超洁亮



超洁亮公司展会岁月志 | Super Clean Exhibition Chronicles

2025

上海国际清洁技术与设备博览会 Shanghai International Cleaning Technology and Equipment Expo

创新驱动，【超洁亮】引领清洁新潮流



2021

第二十八届广州国际酒店用品展 The 28th Guangzhou International Hotel Supplies Exhibition

《志当高远·搏定未来》



2023

上海国际清洁技术与设备博览会 Shanghai International Cleaning Technology and Equipment Expo

《专注品质·铸造品牌》



2020

第二十七届广州国际酒店用品展 The 27th Guangzhou International Hotel Supplies Exhibition

《为梦前行——凝心·聚力·再出发!》



2019

第二十六届广州国际酒店用品展 The 26th Guangzhou International Hotel Supplies Exhibition

《筑梦三十一载 跨越新未来》



2016

第二十三届广州国际酒店用品展 The 23th Guangzhou International Hotel Supplies Exhibition



2017

上海国际清洁技术与设备博览会 Shanghai International Cleaning Technology and Equipment Expo



2024

第三十届广州国际酒店用品展
The 30th Guangzhou International Hotel Supplies Exhibition

《精工细作、品质领航》



2024

荷兰阿姆斯特丹荷兰国际清洁展
Amsterdam International Cleaning Show, Netherlands

《跨越国界、展现卓越》



2023

第二十九届广州国际酒店用品展
The 29th Guangzhou International Hotel Supplies Exhibition

《卓越品质、承载辉煌》



2024

上海国际清洁技术与设备博览会
Shanghai International Cleaning Technology and Equipment Expo

《高端品质、匠心出品》

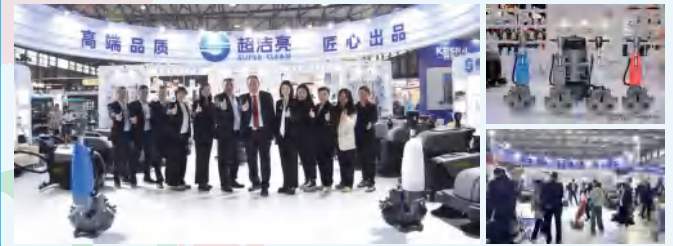

2018

第二十五届广州国际酒店用品展
The 25th Guangzhou International Hotel Supplies Exhibition

《筑梦三十载 跨越新未来》



2018

荷兰阿姆斯特丹荷兰国际清洁展
Amsterdam International Cleaning Show, Netherlands



2017

第二十四届广州国际酒店用品展
The 24th Guangzhou International Hotel Supplies Exhibition



2018

上海国际清洁技术与设备博览会
Shanghai International Cleaning Technology and Equipment Expo





公司实力销售团队
Powerhouse Sales Team of the Company

公司组织员工旅游
Powerhouse Sales Team of the Company



邝总为突出贡献员工颁奖
General Manager Kuang Presents
Awards to Outstanding Contributors

公司组织年会活动
Company-organized Annual Meeting



责任担当

勇于承担 乐于奉献
Responsible & Willing to dedicate



公司董事长兼总经理邝启湘先生
向广州市白云区区长移交善款支票





企业荣誉 | Corporate Honors

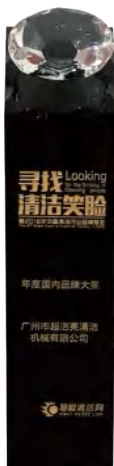

国内品牌大奖



行业杰出贡献奖



3M 公司快速成长奖



3M 20年合作奖

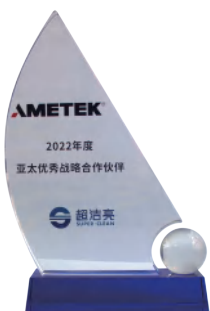

亚太优秀战略合作伙伴



阿美德格亚太最佳战略合作伙伴



阿美德格优秀合作伙伴



ISSA 清洁协会会员证书



纳税大户铜奖



中国工商业联合会会员



中国制造网认证供货商



企业认证 | Enterprise Certification

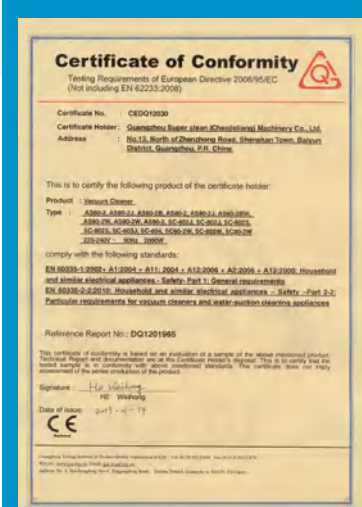

欧盟CE认证

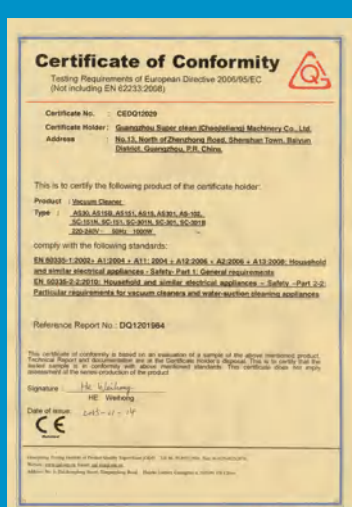

欧盟CE认证

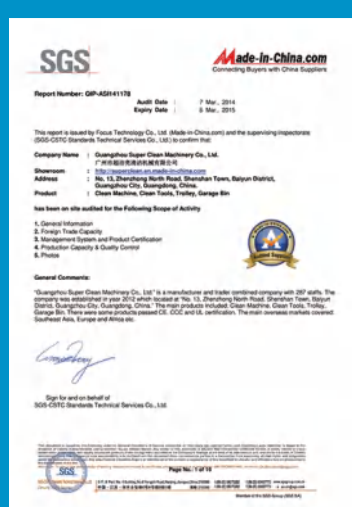

欧盟CE认证



中国 3C 认证



中国 3C 认证

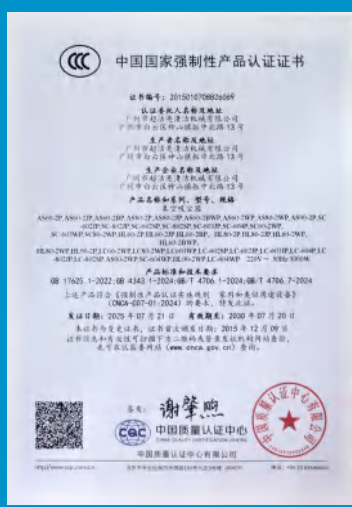

中国 3C 认证

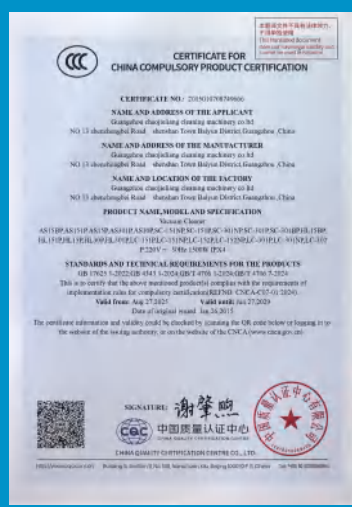

中国 3C 认证



中国 3C 认证



ISSA 证书



CB 证书



ISO9001 认证



ISO9001 认证



品牌荣誉
世界共享

Brand honor
The world to share

目录 Contents

驰丽洁产品系列 Cleaning Machine Series	1~12
清洁机械系列 Cleaning Machine Series	13~36
刷地机系列 Brushing Machine Series	37~46
地毯沙发抽洗机 Light Clean Carpet & Sofa Cleaner	47~54
吸尘吸水机系列 Wet And Dry Vacuum Cleaner	55~89
吹风机、配件系列 Blower & Accessories Series	90~98
环保垃圾桶 Environment Dustbin Series	99~112
清洁工具系列 Cleaning Tools Series	113~126
清洁服务车系列 Cleaning Cart Series	127~133
酒店用品系列 Hotel Supplies Series	134~148
保温箱系列 Thermal insulation box series	149~149
清洁剂品牌系列 General Detergent Series	150~184

专注品质 成就品牌



驰丽洁

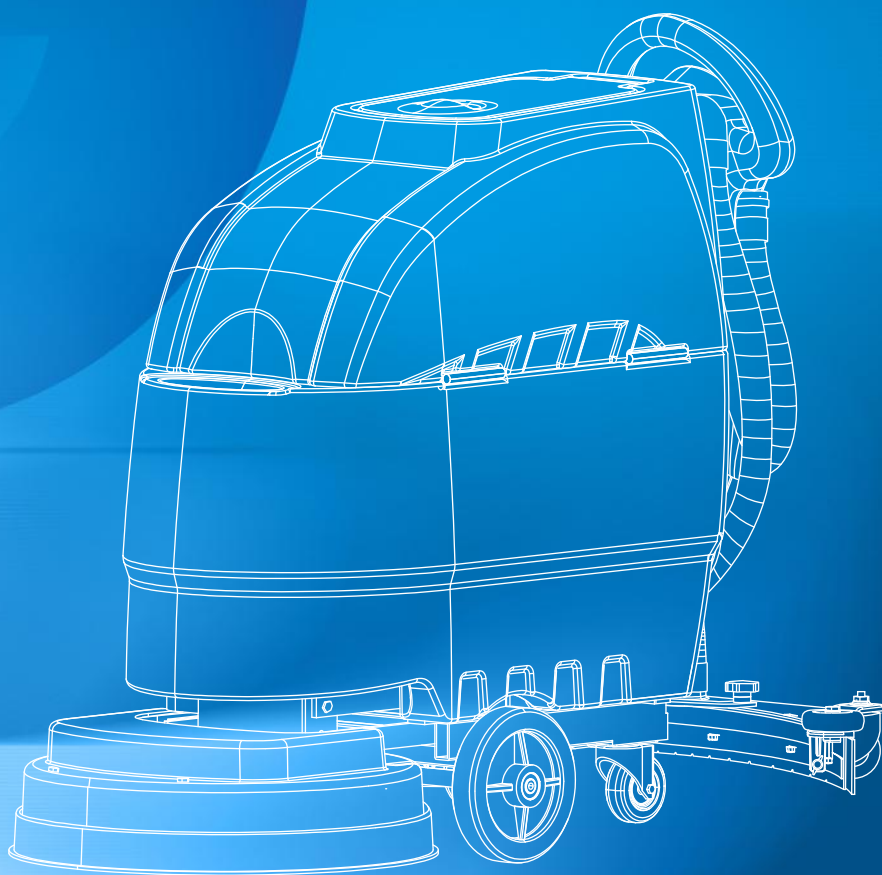



XD-860

静音型驾驶式洗地机

Lower-noise Ride-on Scrubber Dryer



性能优点/Specification



进口吸水马达
 Imported suction motor



进口胶条
 Imported strip



双刷盘
 Double brush set



新款控制面板
 The upgraded control panel

技术参数 Technical Data

	XD-860
电压 Voltage:	24V
行走速度 Speed:	0-6.5km/h
清洁宽度 Cleaning width:	860mm
最大清洁效率 Max. cleaning efficiency:	5500m ² /h
驱动电机 Driving motor:	24V 650W
刷地电机 Floor motor:	24V 450W*2
刷地转速 Brush rotation speed:	160RPM
吸水电机 Water sucker motor:	24V 600W
水扒升降电机 Water scraper lift motor:	24V 60W
刷盘升降电机 Brush disc lift motor:	24V 60W
吸力 Sucking degree:	160mbar
吸水扒宽度 Water sucker:	1200mm
电池组 Battery:	DC24V 4X6V200AH
清水箱容量 Clean water tank capacity:	140L
污水箱容量 Dirty water tank capacity:	150L
净重 Net weight:	389kg
毛重 Gross weight:	460kg
产品尺寸 Product Size:	1575×1210×1315mm
包装尺寸(含地台板) Packing Size (With Pallet):	1760×988×1360mm
颜色 Colour:	

产品特点

- 水箱带有胶圈密封, 14.5KPa 强劲吸力。
- 安装有污水限制电路板, 水满自动断电。
- 控制面板按钮灵敏可靠。
- 最大爬坡能力 30 度, 最大驻车坡度 30 度。
- 前驱驱动。

Features

- Water tank sealed by O-ring ,the suction more than 14.5kpa.
- The circuit board will automatically power-off when the water tank full.
- The control panel layout is high sensitive.
- Maximum grade ability is 30 degrees, maximum parking slope is 30 degrees.
- Front-wheel drive.

随机配件 Contents



16" 刷盘
 16" brush
 16" 针座
 16" pad holder



优质充电器
 Charger



优质蓄电池*4
 Battery*4



XD-660

静音型驾驶式洗地机

Lower-noise Ride-on Scrubber Dryer



性能优点/Specification



进口吸水马达
Imported suction motor



进口胶条
Imported strip



双刷盘
Double brush set



新款控制面板
The upgraded control panel

技术参数 Technical Data

	XD-660
电压 Voltage:	24V
行走速度 Speed:	0-5.5km/h
清洁宽度 Cleaning width:	660mm
最大清洁效率 Max. cleaning efficiency:	3600m ² /h
驱动电机 Driving motor:	24V 480W
刷地电机 Floor motor:	24V 400W*2
刷地转速 Brush rotation speed:	160RPM
吸水电机 Water sucker motor:	24V 500W
升降电机 Lift motor:	24V 60W*2
吸力 Sucking degree:	160mbar
吸水扒宽度 Water sucker:	1080mm
电池组 Battery:	DC24V 2X12V100AH
清水箱容量 Clean water tank capacity:	80L
污水箱容量 Dirty water tank capacity:	85L
净重 Net weight:	255kg
毛重 Gross Weight:	290kg
产品尺寸(含储物箱) Product Size(with storage box):	1520×1080×1145mm
包装尺寸(含地台板) Packing Size (With Pallet):	1420×850×1220mm
颜色 Colour:	

产品特点

- 水箱带有胶圈密封, 14.5KPa 强劲吸力。
- 安装有污水限制电路板, 水满自动断电。
- 控制面板按钮灵敏可靠。
- 最大爬坡能力 30 度, 最大驻车坡度 30 度。
- 后驱驱动。

Features

- Water tank sealed by O-ring ,the suction more than 14.5kpa.
- The circuit board will automatically power-off when the water tank full.
- The control panel layout is high sensitive,.
- Maximum grade ability is 30 degrees, maximum parking slope is 30 degrees.
- Rear-wheel drive.

随机配件 Contents



13" 刷盘
13" brush

13" 针座
13" pad holder



优质充电器
Charger



优质蓄电池*2
Battery*2

MINI-18

迷你双刷洗地机

Mini Dual Brush Scrubber



性能优点/Specification



控制面板操作简单
 The control panel is easy to operate

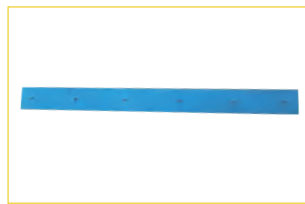

优质PV防油胶条，耐酸耐碱
 High quality PV oil-proof rubber strip, acid and alkali resistant



污水箱内水满保护装置
 Sewage tanks with full water device

技术参数 / Technical Data

	mini-18
额定电压 Rated voltage:	DC24V
工作效率 Work efficiency:	1200m ² /h
刷盘电机 Brush plate motor:	160W*2
清洁宽度 Cleaning width:	520mm
刷盘直径 Brush diameter:	ø230mm*2
刷盘转速 Brush rotation speed:	258RPM
真空马达 Vacuum Motor	150W
电池组 Battery:	12Ah
工作时间 working hours:	1.5h
外形尺寸 Overall dimensions:	518×410×1235mm
包装尺寸 Size:	1260×520×385mm
净重 Net weight:	20kg
毛重 Gross Weight:	28.8kg
颜色 Colour:	

产品特点/Features

- 轻巧灵活，360°旋转清洁不受限制。
- 采用双刷设计，清洁效率更高。
- 超长续航，充满可用1.5小时。
- Lightweight and flexible, 360° rotation for unrestricted cleaning.
- Adopt double brush design, higher cleaning efficiency.
- Extra long battery life, fully available for 1.5 hours.

随机配件/Contents



9"X2 地刷
 2X9" brush



优质锂电池
 lithium battery



优质充电器
 Charger



9"X2 针座
 2X9" Pad holder



9"X2 百洁垫
 2X9" Floor Pad

XD-20/XD-20C

电瓶式 / 电线式自动洗地机

Auto Scrubber With Battery/Cable



性能优点/Specification



控制面板操作简单
The control panel is easy to operate



阿美德格进口马达
Imported suction motor



污水箱内水满保护装置
Sewage equips with full water device



新式吸水扒, 更换胶条简单 无需工具
The new suction grill is simple to replace the rubber strip, No tools required



进口胶条可四面使用, 耐酸耐碱
Imported rubber strips can be used on four sides, acid and alkali resistant

技术参数 / Technical Data

	XD-20	XD-20C
清洁宽度 Cleaning width:	510mm	510mm
吸水扒宽度 Water sucker:	755mm	755mm
刷盘直径 Brush diameter:	Φ510mm	Φ510mm
刷盘转速 Brush rotation speed:	210RPM	160RPM
吸力 Sucking degree:	140mbar	140mbar
洗地电机功率 Floor motor power:	550W	750W
吸水马达功率 Power of water sucking motor:	500W	700W
清水箱容量 Clean water tank capacity:	50L	50L
污水箱容量 Dirty water tank capacity:	55L	55L
清洁效率 Cleaning rate:	1750m ² /h	1750m ² /h
电池组 Battery:	2×12V/100Ah	--
电压 Voltage:	24V.DC	220V/AC
电源线长度 Cable:	--	18m
包装尺寸(含地台板) Packing Size (With Pallet):	1250×630×1170mm	
净重 Net weight:	148kg	75kg
毛重 Gross Weight:	173kg	117kg
颜色 Colour:		

产品特点/Features

- 外观设计紧凑, 外壳与把手一体, 结构牢固。
- 操作面板一目了然, 控制方便简单易操作。
- 污水箱内设有水满装置, 保护吸水马达。
- 选用名牌电池、充电器, 工作时间长。
- 清水箱、污水箱容量大, 保证长时间工作。
- 弧形水刮, 吸水更有效。
- 刷盘加装防护罩, 防止污水外溢。
- Compact design, integrated shell and handle, firm structure
- Operation panel at a glance, convenient control simple operation.
- Sewage equips with full water device, protect suction motor
- Choose brand batteries, chargers, long working hours.
- Clear water tank, sewage tank capacity is big, ensure to work long hours.
- Curved water squeegee, water absorption is more effective.
- Brush plate equipped with the protective cover to prevent the sewage from overflowing.

随机配件/Contents



20" 刷盘
20" brush



20" 针座
20" pad holder



优质蓄电池
Battery



优质充电器
Charger

XD-16/XD-16C

电瓶式 / 电线式自动洗地机 Auto Scrubber With Battery/Cable



性能优点/Specification



进口吸水马达
 Imported suction motor



防撞轮与水量调节阀
 Anti-collision wheel and water regulating valve.



外置充电插口
 External charging socket.



进口胶条可四面使用，耐酸耐碱
 Imported rubber strips can be used on four sides, acid and alkali resistant

产品特点/Features

- 电瓶电线式样，两种选择
- 小巧灵活——清洁边角，转弯灵活，通过性强
- 续航持久——续航可达4小时以上，效率更高
- 操作简单——操控简单易懂，可快速上手
- 动力澎湃——配备500W吸水电机，550W强力洗地电机
- This machine is two kind power supply ,cable and battery for your choice.
- Small and flexible——Clean the corners, turn flexibly and pass through easily.
- Endurance——The endurance can reach more than 4 hours and the efficiency is higher.
- Simple operation——The control is simple and easy to understand and can be used quickly.
- Power strong——Equipped with 500W suction motor, 550W strong ground washing motor.

随机配件/Contents



16" 针座
 16" pad holder



17" 地刷
 17" brush



优质充电器
 Charger



优质蓄电池
 Battery

技术参数 / Technical Data

	XD-16	XD-16C
清洁宽度 Cleaning width	430mm	430mm
吸水扒宽度 Water sucker	530mm	530mm
刷盘直径 Brush diameter	φ430mm	φ430mm
刷盘转速 Brush rotation speed	210RPM	160RPM
吸力 Sucking degree	140mbar	180mbar
洗地电机功率 Floor motor power:	550W	750W
吸水马达功率 Power of water sucking motor	500W	700W
清水箱容量 Clean water tank capacity	25L	25L
污水箱容量 Dirty water tank capacity	25L	25L
清洁效率 Cleaning rate	1700m ² /h	1700m ² /h
电池组 Battery	2x12V 80AH	
电压 Voltage	24V	220V
电源线长度 Cable	--	18m
包装尺寸(含地台板) Packing Size (With Pallet):	870×610×890mm	
净重 Net weight	106kg	60kg
毛重 Gross Weight	121kg	75kg
颜色 Colour		

XD-1050

电瓶式自动洗地机

Auto Scrubber With Battery



性能优点/Specification



人性化水箱挽手设计
提拉方便舒适。

Humanized water tank with a lifting handle, which is convenient and comfortable.

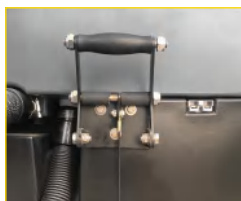

外置充电端口
充电简单便捷。

External charging port simple and convenient.



进口吸水马达
Imported suction motor



进口胶条可四面使用，耐酸耐碱
Imported rubber strips can be used on four sides, acid and alkali resistant



新式吸水扒，更换胶条简单
无需工具

The new suction grill is simple to replace the rubber strip, No tools required

产品特点/Features

- 电瓶电线式样，两种选择。
- 大容积 50 升，每箱清水可洗地 460 平方米。
- 容量大，效率高，价格合理质量稳定，是清洁洗地的理想选择。
- This machine is two kind power supply ,cable and battery for your choice.
- The water tanks big enough ,more than 50L, full clean water can wash 460 square meters.
- Large capacity high efficiency, reasonable price, stable quality is the ideal choice of clean floor.

随机配件/Contents



20" 针座
20" pad holder



20" 地刷
20" brush



优质充电器
Charger



优质蓄电池
Battery

技术参数 / Technical Data

	XD-1050
清洁宽度 Cleaning width	510mm
吸水扒宽度 Water sucker	755mm
刷盘直径 Brush diameter	φ510mm
刷盘转速 Brush rotation speed	210RPM
吸力 Sucking degree	140mbar
洗地电机功率 Floor motor power	550W
吸水马达功率 Power of water sucking motor	500W
清水箱容量 Clean water tank capacity	50L
污水箱容量 Dirty water tank capacity	40L
清洁效率 Cleaning rate	1750m ² /h
电池组 Battery	2×12V 100AH
电压 Voltage	24V
电源线长度 Cable	--
包装尺寸(含地台板) Packing Size (With Pallet):	1250×630×1050mm
净重 Net weight	145kg
毛重 Gross Weight	170kg
颜色 Colour	

XD-50

电瓶式自动洗地机

Auto Scrubber With Battery



性能优点/Specification



新式吸水扒, 更换胶条简单
 无需工具

The new suction grill is simple to replace the rubber strip, No tools required



进口胶条可四面使用, 耐酸耐碱
 Imported rubber strips can be used on four sides, acid and alkali resistant



优质马达
 High quality motor.



进口吸水马达
 Imported suction motor



污水箱内水满保护装置
 Sewage equips with full water device.

技术参数 / Technical Data

	XD-50
清洁宽度 Cleaning width:	510mm
吸水扒宽度 Water sucker:	755mm
刷盘直径 Brush diameter:	Φ510mm
刷盘转速 Brush rotation speed:	210RPM
吸力 Sucking degree:	140mbar
洗地电机功率 Floor motor power:	550W
吸水马达功率 Power of water sucking motor:	500W
清水箱容量 Clean water tank capacity:	40L
污水箱容量 Dirty water tank capacity:	50L
清洁效率 Cleaning rate:	1750m ² /h
电池组 Battery:	2×12v 100Ah
电压 Voltage:	24V.DC
电源线长度 Cable:	--
包装尺寸(含地台板) Packing Size (With Pallet):	1250×630×1050mm
净重 Net weight:	148kg
毛重 Gross Weight:	173kg
颜色 Colour:	

产品特点/Features

- 外观设计紧凑, 外壳与把手一体, 结构牢固。
- 操作面板一目了然, 控制方便简单易操作。
- 污水箱内设有水满装置, 保护吸水马达。
- 选用名牌电池、充电器, 工作时间长。
- 清水箱、污水箱容量大, 保证长时间工作。
- 弧形水刮, 吸水更有效。
- 刷盘加装防护罩, 防止污水外溢。
- Compact design, integrated shell and handle, firm structure
- Operation panel at a glance, convenient control simple operation.
- Sewage equips with full water device, protect suction motor
- Choose brand batteries, chargers, long working hours.
- Clear water tank, sewage tank capacity is big, ensure to work long hours.
- Curved water squeegee, water absorption is more effective.
- Brush plate equipped with the protective cover to prevent the sewage from overflowing.

随机配件/Contents



20" 刷盘
 20" brush



20" 针座
 20" pad holder



优质蓄电池
 Battery



优质充电器
 Charger

XD-70

电瓶式自动洗地机

Auto Scrubber With Battery



性能优点/Specification



新式吸水扒, 更换胶条简单
无需工具

The new suction grill is simple to replace the rubber strip, No tools required



进口胶条可四面使用, 耐酸耐碱
Imported rubber strips can be used on four sides, acid and alkali resistant



优质马达
High quality motor.



进口吸水马达
Imported suction motor

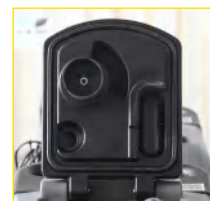

污水箱内水满保护装置
Sewage equips with full water device.

产品特点/Features

- 外观设计紧凑, 外壳与把手一体, 结构牢固。
- 操作面板一目了然, 控制方便简单易操作。
- 污水箱内设有水满装置, 保护吸水马达。
- 选用名牌电池、充电器, 工作时间长。
- 清水箱、污水箱容量大, 保证长时间工作。
- 弧形水刮, 吸水更有效。
- 刷盘加装防护罩, 防止污水外溢。
- Compact design, integrated shell and handle firm structure
- Operation panel at a glance, convenient control simple operation.
- sewage equips with full water device, protect suction motor
- Choose brand batteries, chargers, long working hours.
- Clear water tank, sewage tank capacity is big, ensure to work long hours.
- Curved water squeegee, water absorption is more effective.
- Brush plate equipped with the protective cover to prevent the sewage from overflowing.

随机配件/Contents



20" 刷盘
20" brush



20" 针座
20" pad holder



优质蓄电池
Battery



优质充电器
Charger

技术参数 / Technical Data

	XD-70
清洁宽度 Cleaning width:	510mm
吸水扒宽度 Water sucker:	755mm
刷盘直径 Brush diameter:	Φ510mm
刷盘转速 Brush rotation speed:	210RPM
吸力 Sucking degree:	140mbar
洗地电机功率 Floor motor power:	550W
吸水马达功率 Power of water sucking motor:	500W
清水箱容量 Clean water tank capacity:	65L
污水箱容量 Dirty water tank capacity:	70L
清洁效率 Cleaning rate:	1750m ² /h
电池组 Battery:	2×12v 100Ah
电压 Voltage:	24V.DC
电源线长度 Cable:	--
包装尺寸(含地台板) Packing Size (With Pallet):	1420×680×1080mm
净重 Net weight:	150kg
毛重 Gross Weight:	184.4kg
颜色 Colour:	

XD-18

洗地吸干机

Scrubber



性能优点/Specification



新式吸水扒, 更换胶条简单
 无需工具

The new suction grill is simple to replace the rubber strip, No tools required



进口胶条可四面使用, 耐酸耐碱
 Imported rubber strips can be used on four sides, acid and alkali resistant



翻转式设计
 Tilting design



防撞轮
 Anti-collision wheel



进口吸水电机
 Import suction motor

产品特点/Features

- 翻转式传动机构设计!
- 污水水位限制路板, 水满自动断电!
- 水扒增加可调节高度的小轮设计!
- Tilting transmission mechanism design!
- Sewage water level restrict the circuit board, it will automatically power-off when the water full.
- The water steak increase the small wheel which can adjust the height!

随机配件/Contents



18" 刷盘
 18" brush



18" 针座
 18" pad holder

技术参数 / Technical Data

	XD-18
电压 / 频率 Voltage/Frequency:	220-230V/50Hz
吸水扒宽度 Water sucker:	755mm
刷盘直径 Brush diameter:	455mm
洗地刷马达 Rolling brush motor:	200-240V/750W
吸水马达 Water sucking motor:	220-230V/1000W
洗地刷转速 Brush rotation speed:	148RPM/min
清洁宽度 Cleaning width:	455mm
清洁效率 Cleaning rate:	1660m ² /h
洗地刷压力 Brush pressures:	30kg
清水箱容量 Clean water tank capacity:	27.8L
污水箱容量 Dirty water tank capacity:	31.3L
电源线长度 Cable:	18m
净重 Net weight:	75.6kg
毛重 Gross weight:	98.45kg
包装尺寸(含地台板) Packing Size (With Pallet):	970×620×1120mm
颜色 Colour:	

DT-12

蒸汽地毯抽洗机

Steam Carpet Cleaner



专利产品

Patented product

专利申请号: 201520631442.6

Patent application number: 201520631442.6



污水箱水位控制器
The ewage tank
water level controller



蒸汽发热功能
Steam heating function



冷热出水口
Cold and hot water outlet



窗帘吸扒 (可选配)
Curtain Sucker
(optional)

产品特点/Features

- 体积小、机器本身易清洁。
- 内有清水过滤网避免堵塞。
- 既能独立吸尘、吸水,又能窗帘、地毯清洁;
- 蒸汽、擦洗、吸干多功能集于一体;
- 蒸汽源头125°, 高温杀菌;
- 蒸汽配件多样, 适合不同环境清洗作业;

- Small size, the machine itself is more easy for cleaning.
- A water filter to avoid congestion.
- It can not only dry & wet vacuum independently, but also clean curtains & carpets;
- Steaming, washing & drying are integrated in one machine.
- Steam source is 125°, high temperature sterilization of different types of sofa fabrics.
- Various steam accessories are suitable for cleaning operations in different environments.

随机配件/Contents

- | | | |
|--|-----------------------------------|-----------------------------|
| ① 地毯吸水钢扒连接软管总承
Carpet water sucker Connecting hose main bearing | ⑤ 玻璃刷
Glass brush | ⑩ 圆刷
Small round brush |
| ② 吸水扒
Water sucker | ⑦ 喷枪
Spraying gun | ⑪ 大圆刷
Big round brush |
| ③ 长扁扒
Long flat vacuuming head | ⑧ 地板刷连接头
Floor brush connector | ⑬ 蒸汽吸扒
Steam vacuum head |
| ④ 圆毛刷
Round brush | ⑨ 转换头
Converting head | ⑭ 加长杆
Extension rod |
| ⑤ 地板刷
Floor brush | ⑫ 高压喷咀
High pressure nozzle | ⑮ 蒸汽管3m
Steam pipe 3m |

技术参数 / Technical Data

	DT-12
电压 Voltage:	220-240V/50Hz
总功率 Power:	2862W
总电流 Current:	15A
清水箱容量 Clean water tank capacity:	16L
污水箱容量 Dirty water tank capacity:	12L
蒸汽加热器功率 Steam heater power:	2000W
水泵功率 Power of water pump:	34W/28Hz
吸水电机功率 Power of vacuum motor:	800W
喷水连接管长度 Spraying connecting pipe:	4m
伸缩管长度 Extension tube:	1.5m
配件直径 Hose diameter:	Φ40mm
电源线长度 Cable:	8m
净重 Net weight:	26kg
毛重 Gross weight:	30kg
尺寸 Size:	740×400×650mm
颜色 Colour:	



DT-15/20/30/40

蒸汽地毯抽洗机 Steam Carpet Cleaner



随机配件/Contents

- | | | |
|--|----------------------------|----------------------------------|
| ① 地毯吸水钢扒连接软管总承
Carpet water sucker Connecting hose main bearing | ⑥ 圆毛刷
Round brush | ⑪ 地板刷接头
Floor brush connector |
| ② 吸水扒
Water sucker | ⑦ 弯钢管
Curved steel pipe | ⑫ 转换头
Converting head |
| ③ 尘扒
Dust vacuuming head | ⑧ 地板刷
Floor brush | ⑬ 高压喷嘴
High pressure nozzle |
| ④ 水扒
Water vacuuming head | ⑨ 玻璃刷
Glass brush | ⑭ 圆刷
Small round brush |
| ⑤ 长扁扒
Long flat vacuuming head | ⑩ 喷枪
Spraying gun | ⑮ 蒸汽吸扒
Steam vacuum head |
| | | ⑯ 加长杆
Extension rod |
| | | ⑰ 大圆刷
Big round brush |
| | | ⑱ 蒸汽管3m
Steam pipe 3m |



技术参数 / Technical Data

	DT-15	DT-20	DT-30	DT-40
功能 Function:	蒸汽地毯抽洗机 Steam Carpet cleaner	蒸汽地毯抽洗机 Steam Carpet cleaner	蒸汽地毯抽洗机 Steam Carpet cleaner	蒸汽地毯抽洗机 Steam Carpet cleaner
主机容量 Capacity:	15L	20L	30L	40L
蒸汽水箱容量 Steam water tank capacity:	3L	3L	3L	3L
清水箱容量 Clean Water Capacity:	5L	7L	7L	7L
总功率 Power:	2862W	2862W	2862W	2862W
电压 Voltage:	220V-240V	220V-240V	220V-240V	220V-240V
水泵功率 Power of water pump:	34W/28W	34W/28W	34W/28W	34W/28W
吸水电机功率 Power of vacuum motor:	800W	800W	800W	800W
蒸汽加热器功率 Steam heater power:	2000W	2000W	2000W	2000W
高度 Height:	620mm	720mm	830mm	890mm
桶身直径 Tank diameter:	Φ335mm	Φ335mm	Φ335mm	Φ335mm
冷却模式 Mode of cooling:	循环风冷 Circulating air cooling	循环风冷 Circulating air cooling	循环风冷 Circulating air cooling	循环风冷 Circulating air cooling
气流量 Air flow rate:	48L/S	53L/S	53L/S	53L/S
真空吸力 Vacuum suction:	230mbar	230mbar	230mbar	230mbar
电源线长 Length of the cable:	8m	8m	8m	8m
配件直径 Hose diameter:	Φ40mm	Φ40mm	Φ40mm	Φ40mm
包装规格 Packing:	445×410×650mm	455×410×755mm	455×410×855mm	455×410×920mm
净重 Net weight:	15.83kg	17.5kg	18.8kg	19.8kg
毛重 Gross weight:	17.4kg	19.3kg	20.63kg	21.54kg
压力 Pressures	87PSI	87PSI	87PSI	87PSI
颜色 Colour:	■	■	■	■

产品特点/Features

- 圆桶型不锈钢桶身，坚固耐用
- 配备强劲静音型马达，吸力特强
- 既能独立吸尘、吸水，又能窗帘、地毯清洁；
- 蒸汽、擦洗、吸干多功能集于一体；
- 蒸汽源头125°，高温杀菌；
- 蒸汽配件多样，适合不同环境清洗作业；
- The stainless tank is strong and durable.
- With a powerful lower-noise motor the vacuum cleaner has a special strong suction.
- It can not only dry & wet vacuum independently, but also clean curtains & carpets;
- Steaming, washing & drying are integrated in one machine.
- Steam source is 125°, high temperature sterilization of different types of sofa fabrics.
- Various steam accessories are suitable for cleaning operations in different environments.

要选好质量 还是超洁亮

Super Clean Super Qualify

Cleaning
Machine Series

清洁机械

系列产品

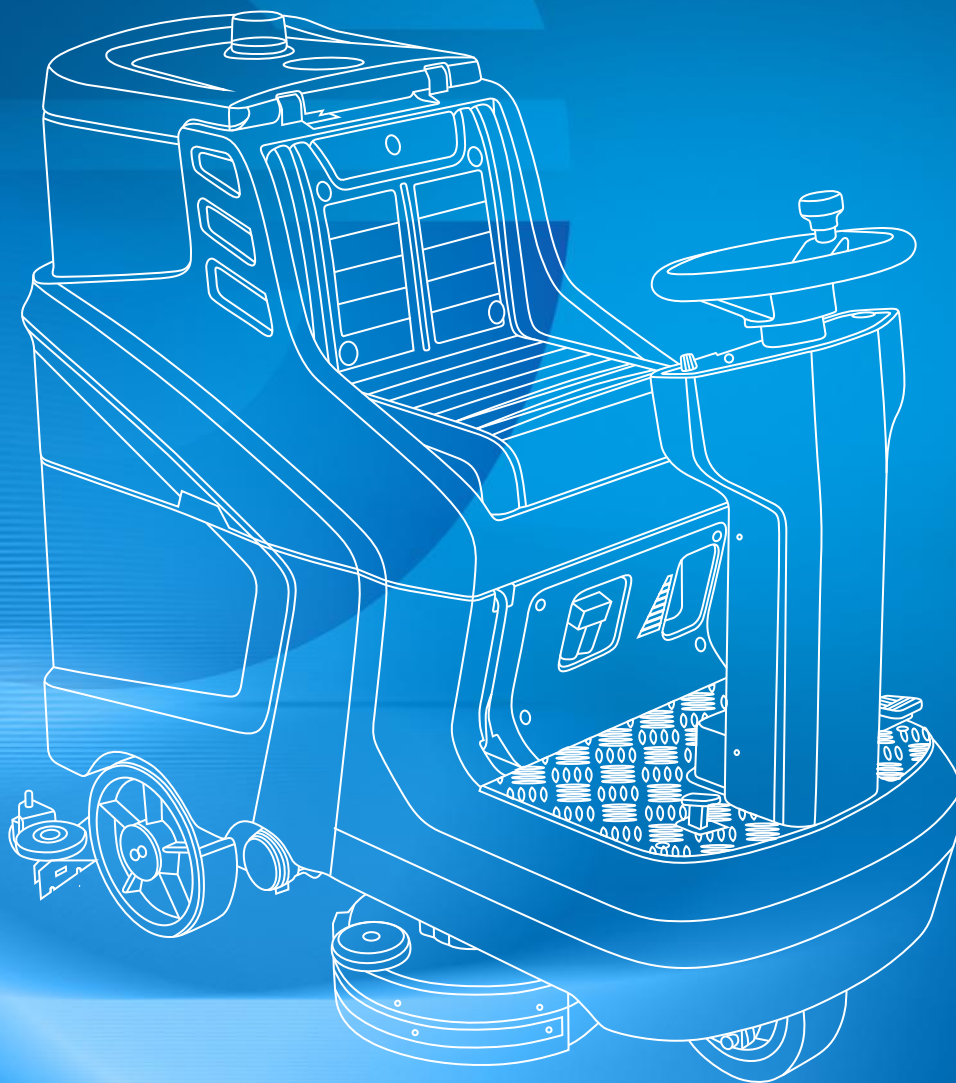

MINI-18

迷你双刷洗地机

Mini Dual Brush Scrubber



性能优点/Specification



控制面板操作简单
The control panel is easy to operate

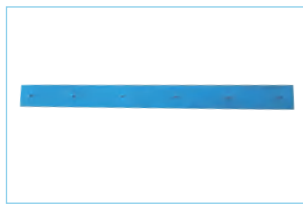

优质PV防油胶条，耐酸耐碱
High quality PV oil-proof rubber strip, acid and alkali resistant



污水箱内水满保护装置
Sewage tanks with full water device

技术参数 / Technical Data

	mini-18
额定电压 Rated voltage:	DC24V
工作效率 Work efficiency:	1200m ² /h
刷盘电机 Brush plate motor:	160W*2
清洁宽度 Cleaning width:	520mm
刷盘直径 Brush diameter:	ø230mm*2
刷盘转速 Brush rotation speed:	258RPM
真空马达 Vacuum Motor	120W
电池组 Battery:	12Ah
工作时间 working hours:	1.5h
外形尺寸 Overall dimensions:	518×410×1235mm
包装尺寸 Size:	1260×520×385mm
净重 Net weight:	20kg
毛重 Gross Weight:	28.8kg
颜色 Colour:	

产品特点/Features

- 轻巧灵活，360°旋转清洁不受限制。
- 采用双刷设计，清洁效率更高。
- 超长续航，充满可用1.5小时。
- Lightweight and flexible, 360° rotation for unrestricted cleaning.
- Adopt double brush design, higher cleaning efficiency.
- Extra long battery life, fully available for 1.5 hours.

随机配件/Contents



9''X2 地刷
2X9'' brush

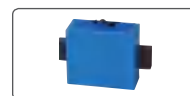

优质锂电池
lithium battery



优质充电器
Charger



9''X2 针座
2X9'' Pad holder



9''X2 百洁垫
2X9'' Floor Pad

SC25D / SC25C

电瓶式/电线式自动洗地机

Auto Scrubber With Battery/Cable



性能优点/Specification



进口吸水马达
Imported suction motor



进口胶条
Imported strip



防撞轮与水量调节阀
Anti-collision wheel
and water regulating valve



外置充电插口
External charging socket.

产品特点

- 电瓶电线式样，两种选择
- 小巧灵活——清洁边角，转弯灵活，通过性强
- 续航持久——续航可达4小时以上，效率更高
- 操作简单——操控简单易懂，可快速上手
- 动力澎湃——配备500W吸水电机，550W强力洗地电机

Features

- This machine is two kind power supply ,cable and battery for your choice.
- Small and flexible——Clean the corners, turn flexibly and pass through easily.
- Endurance——The endurance can reach more than 4 hours and the efficiency is higher.
- Simple operation——The control is simple and easy to understand and can be used quickly.
- Power strong——Equipped with 500W suction motor, 550W strong ground washing motor.

随机配件 Contents



16" 针座
16" pad holder



17" 地刷
17" brush



SC25D
优质充电器
Charger



SC25D
优质蓄电池
Battery

技术参数Technical Data

	SC25D	SC25C
清洁宽度 Cleaning width:	430mm	430mm
吸水扒宽度 Water sucker:	530mm	530mm
刷盘直径 Brush diameter:	φ430mm	φ430mm
刷盘转速 Brush rotation speed:	210RPM	160RPM
吸力 Sucking degree:	140mbar	180mbar
洗地电机功率 Floor motor power:	550W	750W
吸水马达功率 Power of water sucking motor:	500W	700W
清水箱容量 Clean water tank capacity:	25L	25L
污水箱容量 Dirty water tank capacity:	25L	25L
清洁效率 Cleaning rate:	1700m ² /h	1700m ² /h
电池组 Battery:	2x12V 80AH	--
电压 Voltage:	24V	220V
电源线长度 Cable:	--	18m
包装尺寸(含地台板) Packing Size (With Pallet):	870×610×890mm	
净重 Net weight:	106kg	60kg
毛重 Gross Weight:	121kg	75kg
颜色 Colour:		

SC1350

静音型驾驶式洗地机

Lower-noise Ride-on Scrubber Dryer



后吸扒升级
Suction Device Upgrade



性能优点/Specification



进口胶条
Imported strip



进口吸水马达
Imported suction motor



新款控制面板
The upgraded control panel

技术参数 Technical Data

	SC1350
电压 Voltage	24V
功率 Power	2020W
行走速度 Speed	0-5km/h
清洁宽度 Cleaning width	660mm
最大清洁效率 Cleaning rate	3300m ² /h
驱动电机 Driving motor	24V 400W
刷地电机 Floor motor	24V 2×450W
刷地转速 Brush rotation speed	180RPM
吸水电机 Water sucker motor	24V 600W
吸力 Sucking degree	160mbar
吸水扒宽度 Water sucker	1080mm
电池组 Battery	2×12V 120AH
清水箱容量 Clean water tank capacity	80L
污水箱容量 Dirty water tank capacity	70L
升降电机 Lifting motor	24v 2×60W
噪音 Noise	59dB
净重 Net weight	315kg
毛重 Gross weight	350kg
包装尺寸(含地台板) Packing Size (With Pallet):	1420×850×1360mm
颜色 Colour	

产品特点

- 水箱带有胶圈密封, 14.5KPa 强劲吸力。
- 安装有污水限制电路板, 水满自动断电。
- 控制面板按钮灵敏可靠, 有中英文切换, 反应使用情况。
- 最大爬坡能力 30 度, 最大驻车坡度 30 度。

Features

- Water tank sealed by O-ring ,the suction more than 14.5kpa.
- The circuit board will automatically power-off when the water tank full.
- The control panel layout is high sensitive, you can choose the chinese and english language. Which can reflect the use condition.
- Maximum grade ability is 30 degrees, maximum parking slope is 30 degrees.

随机配件 Contents



13" 刷盘
13" brush



13" 针座
13" pad holder



优质蓄电池
Battery



优质充电器
Charger

AS-2007

驾驶式洗地机

Ride-on Scrubber Dryer



性能优点/Specification

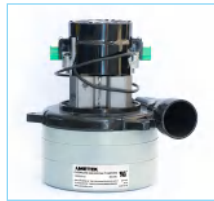

进口吸水马达
Imported suction motor



优质胶条
High quality strip



双刷盘
Double brush set



新款控制面板
The upgraded control panel

技术参数 Technical Data

	AS-2007
电压 Voltage:	36V
功率 Power:	2365W
电流 Current:	70A
行走速度 Speed:	0~6.5km/h
清洁宽度 Cleaning width:	820mm
清洁效率 Cleaning rate:	5330m ² /h
驱动电机 Driving motor:	36V 650W
刷地电机 Floor motor:	36V 900W 30A
刷地转速 Brush rotation speed:	170RPM
吸水电机 Water sucker motor:	36V 600W
吸力 Sucking degree:	160mbar
水扒升降电机 Water sucker lift motor:	36V 100W 5A
地刷升降电机 Floor brush lift motor:	36V 60W 3.5A
吸水扒宽度 Water sucker:	1100mm
照明 Lighting:	36V 55W 2A
电池组 Battery:	6×6V 200AH
清水箱容量 Clean water tank capacity:	125L
污水箱容量 Dirty water tank capacity:	132L
毛重 Gross weight:	635kg
净重 Net weight:	520kg
包装尺寸(含地台板) Packing Size (With Pallet):	1760×988×1460mm
颜色 Colour:	

产品特点

- 每小时可清洁 1200 平方米 -2800 平方米。
- 驾驶平稳，最小转弯半径 1.5 米，爬坡能力 30 度。
- 安装有 1 只 600W 阿美德格吸水电机，噪声低、寿命长。

Features

- It can clean 1200 square meters - 2800 square meters per hour.
- Smooth driving, the minimum turning radius of 1.5 meters, gradeability 30 degrees.
- Equipped with three 600W AMETEK suction motors, low noise, long service life.

随机配件 Contents



16" 刷盘 16" 针座 优质充电器 优质蓄电池
16" brush 16" pad holder Charger Battery(6pcs)

SC2008

驾驶式扫地机

Ride-on sweeper

1400 mm

专业高效解决市政道路、小区街道、校园、景区、广场、市场等地面清洁。
特别适合小区、仓库、工厂、车间等。
总电压 48V，使用时间可达 5 小时

Professional and efficient solutions to municipal roads, community streets, campuses, scenic spots, squares, markets and other floor cleaning. Especially suitable for small area, warehouse, factory, workshop, etc. The total voltage is 48V and the service time can be up to 5 hours



产品特点

- 舒适的座椅设计，良好的操作视野；
- 高底盘通过下更强，清扫宽到 1.3 米；
- 进口欧美电控系统，集约式设计安装，过流保护，欠压保护；
- 120L 超大垃圾箱提高清洁效果及效率；
- 55 分贝低噪音设计，专利控尘系统，控尘能力强，无二次扬尘；
- 专利前轮避震设计有效保护整车控制系统、电源系统以及动力系统，增加操作舒适性和安全性。

Features

- Comfortable seat design, good operating vision;
- The high chassis is stronger through the lower one and the sweeping width is 1.3 meters wide;
- Imported European and American electronic control system, intensive design and installation, overcurrent protection, undervoltage protection;
- 120L large garbage bin improves cleaning efficiency and efficiency;
- 55 decibel low noise design, patented dust control system, strong dust control, no secondary dust;
- The patented front wheel suspension design effectively protects the vehicle control system, power system and power system for increased operational comfort and safety.

技术参数 Technical Data

	SC2008
宽度 (含刷) Width(included brush):	1400mm
续航时间 Continuous Work Time:	5h
清扫效率 Productivity:	9200m ² /h
清水箱容量 Clean Water Tank Capacity:	70L
垃圾箱容量 Waste Hopper Capacity:	170L
过滤面积 (滤芯) Filiter Surface:	5m ²
主刷尺寸 Main Brush Length:	700*305mm
边刷尺寸 Side Brush' s Diameter:	500mm
行驶速度 Work Speed:	0-8km/h
工作速度 Driving Speed:	0-7km/h
坡度 Gradient:	<25°
电压 oltage:	48V
作业功率 Working Power:	500+200+600W
驱动功率 Driving Power:	1200W
包装尺寸 Size:	1945x1185x1565mm
毛重 Gross weight:	530kg
净重 Net weight:	450kg
颜色 Colour:	

随机配件 Contents



前边刷
The front side brushes



优质充电器
Charger



4块
优质蓄电池
Battery(4pcs)

AS-690

电瓶式扫地机

Battery Sweeping Machine



性能优点/Specification



后倾式垃圾箱
Tilting back dustbin



扶手调节装置
Armrest adjusting device



洒水装置
Spraying function

技术参数 Technical Data

	AS-690
清洁宽度 Cleaning width:	1000mm
清扫效率 Cleaning efficiency	4000m ² /h
电压 Voltage:	12V
总功率 Total power:	270W
电池组 Battery:	12V 100AH
续航时间 Battery life:	5H
滤尘面积 Dust filter area	1.5m ²
垃圾箱容积 Trash can volume	22L
选配水箱容积 Optional tank volume	12L
包装尺寸(含地台板) Packing Size (With Pallet):	1010×955×780mm
净重 Net weight:	90kg
毛重 Gross Weight:	116kg
颜色 Colour:	

随机配件 Contents



优质蓄电池
Battery



优质充电器
Charger

产品特点

- 外观时尚，线条既流畅又有力量感，色彩丰富多样
- 结构坚固，高强度的钣金焊接，耐刮擦抗撞击
- 可前后翘起，通过性强
- 扶手可折叠，角度调整方便，可适应不同身高人士操作
- 可加配洒水功能，抑制细微扬尘，满足高端场所的清扫
- 总噪音低于58分贝，最适合要求清静场所清扫
- 优质免维护蓄电池，充电时间短，续航可达5小时
- 强力吸风电机和高效空气过滤器，清扫中无扬尘

Features

- Fashionable appearance, smooth & powerful lines, colorful colors.
- Strong structure, high strength sheet metal welding, anti-scratch & anti-impact.
- Operation panel indicates clear and simple operation.
- Handle can be folded, angle adjustment is convenient, can adapt to different heights of operations.
- You can choose to add with sprinkle function, suppress the slight dust to meet the cleaning of high-end venues.
- The whole machine is quipped with high quality maintenance free battery & charger, with short charging time & up to 5 hours of endurance tim
- The total noise of motor is lower than 58db, which is most suitable for the cleaning of quiet places .
- Powerful suction motor and efficient air filter, ensure no dust in cleaning.

AS-1050 / AS-1050C

电瓶式 / 电线式自动洗地机

Auto Scrubber With Battery/Cable



进口吸水马达
Imported suction motor

性能优点/Specification



人性化水箱挽手设计，提拉方便舒适。
Humanized water tank with a lifting handle, which is convenient and comfortable

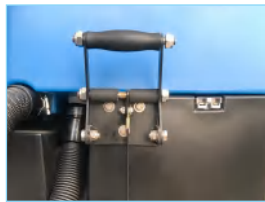

外置充电端口，充电简单便捷。
External charging port, simple and convenient



进口胶条
Imported strip

产品特点

- 电瓶电线式样，两种选择。
- 大容量 50 升，每箱清水可洗地 460 平方米。
- 容量大，效率高，价格合理质量稳定，是清洁洗地的理想选择。

Features

- This machine is two kind power supply ,cable and battery for your choice.
- The water tanks big enough ,more than 50L, full clean water can wash 460 square meters.
- Large capacity high efficiency, reasonable price, stable quality is the ideal choice of clean floor.

随机配件 Contents



20" 针座
20" pad holder



20" 地刷
20" brush



优质充电器
Charger



优质蓄电池
Battery

技术参数 Technical Data

	AS-1050	AS-1050C
清洁宽度 Cleaning width	510mm	510mm
吸水扒宽度 Water sucker	755mm	755mm
刷盘直径 Brush diameter	φ510mm	φ510mm
刷盘转速 Brush rotation speed	210RPM	160RPM
吸力 Sucking degree	140mbar	160mbar
洗地电机功率 Floor motor power	550W	750W
吸水马达功率 Power of water sucking motor	500W	700W
清水箱容量 Clean water tank capacity	50L	50L
污水箱容量 Dirty water tank capacity	40L	40L
清洁效率 Cleaning rate	1750m ² /h	1750m ² /h
电池组 Battery	2×12V 100AH	--
电压 Voltage	24V	220V
电源线长度 Cable	--	18m
包装尺寸(含地台板) Packing Size (With Pallet)		1250×630×1050mm
净重 Net weight	145kg	75kg
毛重 Gross Weight	170kg	100kg
颜色 Colour		

SC50D / SC50C

电瓶式 / 电线式自动洗地机

Auto Scrubber With Battery/Cable



性能优点/Specification



优质马达
High quality motor



进口吸水马达
Imported suction motor



污水箱内水满保护装置
Sewage tanks with
full water device



进口胶条
Imported strip

技术参数 Technical Data

	SC50D	SC50C
清洁宽度 Cleaning width:	510mm	510mm
吸水扒宽度 Water sucker:	755mm	755mm
刷盘直径 Brush diameter:	Φ510mm	Φ510mm
刷盘转速 Brush rotation speed:	210RPM	160RPM
吸力 Sucking degree:	140mbar	180mbar
洗地电机功率 Floor motor power:	550W	750W
吸水马达功率 Power of water sucking motor:	500W	700W
清水箱容量 Clean water tank capacity:	40L	40L
污水箱容量 Dirty water tank capacity:	50L	50L
清洁效率 Cleaning rate:	1750m ² /h	1750m ² /h
电池组 Battery:	2×12v 100Ah	--
电压 Voltage:	24V.DC	220V
电源线长度 Cable:	--	18m
包装尺寸(含地台板) Packing Size (With Pallet):	1250×630×1050mm	
净重 Net weight:	148kg	78kg
毛重 Gross Weight:	173kg	国内107kg / 出口117kg
颜色 Colour:		

产品特点

- 外观设计紧凑，外壳与把手一体，结构牢固。
- 操作面板一目了然，控制方便简单易操作。
- 污水箱内设有水满装置，保护吸水马达。
- 选用名牌电池、充电器，工作长时间。
- 清水箱、污水箱容量大，保证长时间工作。
- 弧形水刮，吸水更有效。
- 刷盘加装防护罩，防止污水外溢。

Features

- Compact design, integrated shell and handle, firm structure
- Operation panel at a glance, convenient control simple operation.
- Sewage tanks with full water device, protect suction motor
- Choose brand batteries, chargers, long working hours.
- Clear water tank, sewage tank capacity is big, ensure to work long hours.
- Curved water squeegee, water absorption is more effective.
- Brush plate equipped with the protective cover to prevent the sewage from overflowing.

随机配件 Contents



20" 刷盘
20" brush



20" 针座
20" pad holder



优质蓄电池
Battery



优质充电器
Charger

SC70D / SC70C

电瓶式 / 电线式自动洗地机

Auto Scrubber With Battery/Cable



性能优点/Specification



优质马达
High quality motor



进口吸水马达
Imported suction motor



污水箱内水满保护装置
Sewage tanks with
full water device



进口胶条
Imported strip

产品特点

- 外观设计紧凑，外壳与把手一体，结构牢固。
- 操作面板一目了然，控制方便简单易操作。
- 污水箱内设有水满装置，保护吸水马达。
- 选用名牌电池、充电器，工作时长。
- 清水箱、污水箱容量大，保证长时间工作。
- 弧形水刮，吸水更有效。
- 刷盘加装防护罩，防止污水外溢。

Features

- Compact design, integrated shell and handle firm structure
- Operation panel at a glance, convenient control simple operation.
- sewage tanks with full water device, protect suction motor
- Choose brand batteries, chargers, long working hours.
- Clear water tank, sewage tank capacity is big, ensure to work long hours.
- Curved water squeegee, water absorption is more effective.
- Brush plate equipped with the protective cover to prevent the sewage from overflowing.

随机配件 Contents



20" 刷盘
20" brush



20" 针座
20" pad holder



优质蓄电池
Battery



优质充电器
Charger

技术参数 Technical Data

	SC70D	SC70C
清洁宽度 Cleaning width:	510mm	510mm
吸水扒宽度 Water sucker:	755mm	755mm
刷盘直径 Brush diameter:	Φ510mm	Φ510mm
刷盘转速 Brush rotation speed:	210RPM	160RPM
吸力 Sucking degree:	140mbar	180mbar
洗地电机功率 Floor motor power:	550W	750W
吸水马达功率 Power of water sucking motor:	500W	700W
清水箱容量 Clean water tank capacity:	65L	65L
污水箱容量 Dirty water tank capacity:	70L	70L
清洁效率 Cleaning rate:	1750m ² /h	1750m ² /h
电池组 Battery:	2×12v 100Ah	--
电压 Voltage:	24V.DC	220V
电源线长度 Cable:	--	18m
包装尺寸(含地台板) Packing Size (With Pallet):	1420×680×1080mm	
净重 Net weight:	150kg	82.5kg
毛重 Gross Weight:	184.4kg	115kg
颜色 Colour:		

SC-461

电瓶式自动洗地吸干机

Auto Scrubber With Battery



性能优点/Specification



进口吸水马达
Imported suction motor



操作面板
Operation panel



进口胶条
Imported strip

技术参数 Technical Data

	SC-461
清洁宽度 Cleaning width:	510mm
吸水扒宽度 Water sucker:	755mm
刷盘直径 Brush diameter:	Φ510mm
刷盘转速 Brush rotation speed:	282RPM
刷盘压力 Brush pressures:	38kg
洗地电机功率 Floor motor power:	800W
吸水马达电压 Voltage of water sucking motor:	24V
吸水马达功率 Power of water sucking motor:	500W
清水箱容量 Clean water tank capacity:	35L
污水箱容量 Dirty water tank capacity:	45L
吸水真空度 Water sucking vacuum degree:	145KPA
噪音 Noise:	<70dB
清洁效率 Cleaning rate:	1750m ² /h
电池组 Battery:	2×12V 100AH
毛重 Gross weight:	192kg
净重 Net weight:	169kg
电源线长度 Cable:	--
包装尺寸(含地台板) Packing Size (With Pallet):	1350×680×1100mm
颜色 Colour:	

产品特点

- 进口胶条，优质品质保证！
- 手柄可调节高度，方便不同人群使用。
- 内部独特铝合金结构，机身更坚实。

Features

- Import strip, Good quality guarantee.
- The adjustable height handle, convenient for different population to use.
- Internal unique aluminum alloy structure, more solid fuselage!

随机配件 Contents



20" 刷盘
20" brush



20" 针座
20" pad holder



优质充电器
Charger



优质蓄电池
Battery

SC2A

洗地吸干机 Scrubber

蝴蝶形手柄
New Butterfly Handle

经典BDA手柄
Classic BDA handle



性能优点/Specification



翻转式设计
Tilting design



后吸水扒
The rear water sucker



防撞轮
Anti-collision wheel



进口吸水电机
Imported suction motor

产品特点

- 翻转式传动机构设计!
- 污水水位限制路板, 水满自动断电!
- 水扒增加可调节高度的小轮设计!

Features

- Tilting transmission mechanism design!
- Sewage water level restrict the circuit board, it will automatically power-off when the water full.
- The water steak increase the small wheel which can adjust the height!

随机配件 Contents



18" 刷盘
18" brush



18" 针座
18" pad holder

技术参数 Technical Data

	SC2A
电压 / 频率 Voltage/Frequency:	220-230V/50Hz
吸水扒宽度 Water sucker:	755mm
刷盘直径 Brush diameter:	455mm
洗地刷马达 Rolling brush motor:	200-240V/750W
吸水马达 Water sucking motor:	220-230V/1000W
洗地刷转速 Brush rotation speed:	148RPM/min
清洁宽度 Cleaning width:	455mm
清洁效率 Cleaning rate:	1660m ² /h
洗地刷压力 Brush pressures:	30kg
清水箱容量 Clean water tank capacity:	27.8L
污水箱容量 Dirty water tank capacity:	31.3L
电源线长度 Cable:	18m
净重 Net weight:	75.6kg
毛重 Gross weight:	98.45kg
包装尺寸(含地台板) Packing Size (With Pallet):	970×620×1120mm
颜色 Colour:	

SC3A / SC3AC

电瓶式 / 电线式洗地吸干机

Scrubber With Battery/Cable



性能优点/Specification



进口吸水马达
Imported suction motor



后吸水扒
The rear water sucker



可收缩前轮
Retractable wheels

技术参数 Technical Data

	SC3A	SC3AC
电压 Voltage:	24V	220-240V
频率 Frequency:	--	50Hz
电流 Current:	51A	9.7A
功率 Power:	1100W	1750W
刷地电机 Floor motor:	600W	750W
刷盘转速 Brush rotation speed:	168RPM	168RPM
吸水电机 Water sucking motor:	500W	1000W
清洁宽度 Cleaning width:	415mm	415mm
清洁效率 Cleaning rate:	1600m ² /h	1600m ² /h
吸水扒宽度 Water sucker:	755mm	755mm
清水箱容量 Clean water tank capacity:	31L	31L
污水箱容量 Dirty water tank capacity:	23L	23L
电池组 Battery:	2×12V	--
放水电磁阀 Electromagnetic value:	24V	220-240V
净重 Net weight:	138kg	77kg
毛重 Gross weight:	179kg	105kg
电源线长度 Cable:	--	18m
包装尺寸(含地台板) Packing Size (With Pallet):	1090×780×880mm	
颜色 Colour:		

产品特点

- 分拆式水箱设计，运输更方便！
- 贴心的前小轮，机器行走更便捷！
- 手柄可调节高度，方便不同人群使用。

Features

- The water tank can be splited,transport more convenient.
- With the little front wheel before, machine walking more convenient!
- The adjustable height handle,convenient for different population to use.

随机配件 Contents



17" 刷盘
17" brush

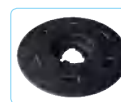

17" 针座
17" pad holder



优质充电器
Charger



优质蓄电池
Battery

DTJ3A

三合一地毯抽洗机 Three-in-one Carpet Cleaner



窗帘吸扒 (可选配)
Curtain Sucker (optional)

性能优点/Specification



操控手柄
Handle



放水管
Sewage pipe



吸水扒
Water sucker



洗地毯滚刷
Rolling brush

产品特点

- 集喷水、洗刷、吸水三功能为一体。
- 水箱内部增加清洁滤网，喷嘴不堵塞。
- 外接 4m 吸水管与水吸扒，使清洁 4m 之内的范围。
- 窗帘吸扒，一机多能，免却窗帘或沙发套的拆卸，水雾清洗，瞬间吸干。

Features

- Spraying water, washing, absorbing water three into one.
- Increase the filter screen inside the water tank, non-clagging nozzle.
- An external 4m suction pipe and water absorption, enables to clean within 4 meters.
- Curtain sucker multifunctional in one machine, very convenient, no need to remove the curtain or sofa cover in washing, wash with water mist and 80% dry in short-time.



随机配件 Contents

4米外接套管+手提吸扒
4-meter external connecting sleeve
+ handheld suction nozzle

技术参数 Technical Data

	DTJ3A
电压 / 频率 Voltage/Frequency:	220V/50Hz
功率 Power:	1290W
电流 Current:	5.3A
滚刷转速 Roll brush speed:	1100rpm/min
滚刷马达 Roll brush motor:	220V/180W
滚刷宽度 Roll brush width:	400mm
清洁效率 Cleaning rate:	400m ² /h
吸水马达 Water sucking motor:	220V/1000W
水泵压力 Pump Pressures:	30PSI
吸水扒宽度 Water sucker:	460mm
喷水马达 Water spray motor:	220V /110W
清水箱容量 Clean water tank capacity:	20L
污水箱容量 Dirty water tank capacity:	18L
电源线长度 Cable:	18m
净重 Net weight:	46kg
毛重 Gross weight:	65kg
包装尺寸(含地台板) Packing Size (With Pallet):	1000×545×1075mm
颜色 Colour:	

DTJ4A

三合一冷热水地毯抽洗机

Three-in-one Cold & Hot Water Carpet Cleaner



窗帘吸扒 (可选配)
Curtain Sucker (optional)

性能优点/Specification



冷热水功能
Cold and hot water
function



吸水扒
Water sucker



洗地毯滚刷
Rolling brush

技术参数 Technical Data

	DTJ4A
电压 / 频率 Voltage/Frequency:	220V/50Hz
功率 Power:	3290W
电流 Current:	15A
滚刷转速 Roll brush speed:	1100rpm/min
滚刷马达 Roll brush motor:	220V/180W
滚刷宽度 Roll brush width:	400mm
清洁效率 Cleaning rate:	400m ² /h
吸水马达 Water sucking motor:	220V/1000W
水泵压力 Pump Pressures:	30PSI
吸水扒宽度 Water sucker:	460mm
喷水马达 Water spray motor:	220V /110W
发热器 Calorifere:	2000W
清水箱容量 Clean water tank capacity:	20L
污水箱容量 Dirty water tank capacity:	18L
电源线长度 Cable:	12m
净重 Net weight:	49kg
毛重 Gross weight:	68kg
包装尺寸(含地台板) Packing Size (With Pallet):	1000×545×1075mm
颜色 Colour:	

产品特点

- 集喷水、洗刷、吸水三功能为一体。
- 快速加热水温，恒定温度清洗，30°C -55°C。
- 减少清洁剂用量，不伤地毯材质，清洗后地毯更蓬松。
- 窗帘吸扒，一机多能，免却窗帘或沙发套的拆卸，水雾清洗，瞬间吸干。

Features

- Spraying water , washing, absorbing water three into one.
- Heating water temperature quickly and constant temperature cleaning, 30°C -55°C .
- Reduce amount of cleaning agents ,not to hurt the carper material but more fluffy after washing the carpet.
- Curtain sucker multifunctional in one machine, very convenient, no need to remove the curtain or sofa cover in washing, wash with water mist and 80%dry in short-time.

随机配件 Contents



4米外接套管+手提吸扒
4-meter external connecting sleeve
+ handheld suction nozzle



DTJ5A

三合一地毯抽洗机

Three-in-one Carpet Cleaner



窗帘吸扒(可选配)
Curtain Sucker (optional)

DTJ5AR

三合一冷热水地毯抽洗机

3-in-1 Hot and Cold Water Carpet Cleaner



性能优点/Specification



污水箱内水满
保护装置
Sewage tanks with
full water device



吸水扒
Water sucker



洗地毯滚刷
Rolling brush



进口吸水马达
(2个)
Imported suction
motor X2



操控手柄
Handle



优质吸水马达
(1个)
High quality suction motor X1

技术参数 Technical Data

	DTJ5A	DTJ5AR
电压 / 频率 Voltage/Frequency:	220V/50Hz	220V/50Hz
功率 Power:	2320W	3320W
滚刷转速 Roll brush speed:	1400rpm/min	1400rpm/min
滚刷马达 Roll brush motor:	220V/190W	220V/190W
滚刷宽度 Roll brush width:	400mm	400mm
吸水马达 Water sucking motor:	220V/1000W X2	220V/1000W
加热器 Heater:		2000W
水泵 Water Pump	130W	130W
吸水扒宽度 Water sucker:	460mm	460mm
清水箱容量 Clean water tank capacity:	35L	35L
污水箱容量 Dirty water tank capacity:	35L	35L
电源线长度 Cable:	18m	12m
净重 Net weight:	50kg	48.5kg
毛重 Gross weight:	69.5kg	70.66kg
包装尺寸(含地台板) Packing Size (With Pallet):	1120×560×1050mm	1120×560×1050mm
颜色 Colour:		

产品特点

- 机身设计新颖小巧，使用灵活方便。
- 快速拆装手提吸扒。
- 喷嘴内部增加清洁滤网，喷嘴不堵塞。
- 集喷射、洗刷、冲洗、吸干四功能为一体，令地毯彻底干净。
- 窗帘吸扒，一机多能，免却窗帘或沙发套的拆卸，水雾清洗，瞬间吸干。

Features

- Novel and compact design, flexible and convenient to use.
- Quickly disassembly & assembly of portable water sucker.
- Add the clean filter inside the nozzle, the nozzle won't be clogged.
- spraying, scrubbing, rinsing and sucking dry are integrated to make the carpet thoroughly clean.
- Curtain sucker multifunctional in one machine, very convenient, no need to remove the curtain or sofa cover in washing, wash with water mist and 80% dry in short-time.

随机配件 Contents



4米外接套管+手提吸扒
4-meter external connecting sleeve
+ handheld suction nozzle

DTJ1A

分体式地毯抽洗机

Carpet Extraction Machine



DTJ1AR

分体式冷热水地毯抽洗机

Split-type Cold & Hot Water Carpet Extraction Machine



性能优点/Specification



操控手柄
Handle



进口吸水马达(3个)
Imported suction motor(X3)



角度调节
Angle adjustment



冷热水功能
Cold / Hot Water
Function



优质吸水马达
High quality suction motor

产品特点

- 进口马达保证质量。
- 水箱内部增加清洁滤网，不堵塞。
- 外接 7.5m 吸水管与水吸扒，使清洁 7.5m 之内的范围。
- 窗帘吸扒，一机多能，免却窗帘或沙发套的拆卸，水雾清洗，瞬间吸干。

Features

- Import motor, quality guarantee!
- Inside the water tank, increase the filter screen non-clogging.
- An external 7.5m suction pipe and water absorption, enables to clean within 7.5 meters.
- Curtain sucker multifunctional in one machine, very convenient, no need to remove the curtain or sofa cover in washing, wash with water mist and 80% dry in short-time.

随机配件 Contents



7.5米外接套管
+手提吸扒
7.5-meter external
connecting sleeve +
handheld suction nozzle



分体扒头
Portable suction
squeegee



窗帘吸扒 (可选配)
Curtain Sucker (optional)

技术参数 Technical Data

	DTJ1A	DTJ1AR
电压 / 频率 Voltage/Frequency:	220-240V/50Hz	220-240V/50Hz
功率 Power:	3230W	3230W
电流 Current:	12.7A	12.7A
滚刷转速 Roll brush speed:	1300rpm/min	1300rpm/min
滚刷马达 Roll brush motor:	230V/180W	230V/180W
滚刷宽度 Roll brush width:	400mm	400mm
清洁效率 Cleaning rate:	560m ² /h	560m ² /h
吸水马达 Water sucking motor:	3000W	1000W
加热器 Heater:		2000W
水泵压力 Pump Pressures:	30PSI	30PSI
吸水扒宽度 Water sucker:	480mm	480mm
喷水马达 Water spray motor:	220-240V /110W	220-240V /110W
清水箱容量 Clean water tank capacity:	49L	49L
污水箱容量 Dirty water tank capacity:	42L	42L
电源线长度 Cable:	12m	12m
净重 Net weight:	87.5kg	87.5kg
毛重 Gross weight:	111.5kg	111.5kg
包装尺寸(含地台板) Packing Size (With Pallet):	1060×610×1105mm	
吸水扒尺寸 Water sucker size:	535×190×1455mm	
颜色 Colour:		

XD760B / XD650B

双刷洗地机

Dual-brush Ground Cleaning Machine



性能优点/Specification



进口吸水马达
Imported suction motor

产品特点

- 洗地机拥有自走功能，操作轻松
- 每小时可清洁 1000 平方米 -2800 平方米。
- 70 升大容量水箱，适合各种大型场地使用。
- 电池单次充电可使用 3.5 小时，质量好，寿命长。

Features

- Washing machine has self - walking function, easy to operate
- It can clean 1000 square meters - 2800 square meters per hour.
- 70 litres of large-capacity water tank, suitable for all kinds of large site use.
- A single battery charge can use 3.5 hours, good quality, long service life.

随机配件 Contents



XD760B 15'' 刷盘
15'' brush



15'' 针座 x 2 个
15'' pad holder



优质蓄电池
Battery



XD650B 13'' 刷盘
13'' brush



13'' 针座 x 2 个
13'' pad holder x 2



优质充电器
Charger

技术参数 Technical Data

	XD760B/XD650B	
电压 Voltage:	24V	
功率 Power:	2110W	
电流 Current:	55A	
行走速度 Speed:	1.5-5Km/h	
清洁宽度 Cleaning width:	760mm/30inch	650mm/26inch
清洁效率 Cleaning rate:	1140-2800m ² /h	1000-2250m ² /h
驱动电机 Driving motor:	24V 450W 7.5A	
刷地电机 Floor motor:	24V 2×450W 20A	
刷地转速 Brush rotation speed:	140RPM	
吸水电机 Water sucker motor:	24V 600W 22A	
吸力 Sucking degree:	140mbar	
增压泵 Pressure pump:	24V 3L/min 3A 100W	
吸水扒宽度 Water sucker:	980mm	
电池组 Battery:	4×6V 200AH	
充电时间 Charge time:	8-12Hour	
电瓶使用时间 Hours time:	3.5Hour	
清水箱容量 Clean water tank capacity:	70L	
污水箱容量 Dirty water tank capacity:	65L	
净重 Net weight:	312.5kg	309.5kg
毛重 Gross weight:	347.5kg	344.5kg
包装尺寸(含地台板) Packing Size (With Pallet):	1460×840×1210mm	
颜色 Colour:	—	

XD510B

单刷洗地机

Single-brush Ground Cleaning Machine



性能优点/Specification



进口吸水马达
Imported suction motor

技术参数 Technical Data

	XD510B
电压 Voltage:	24V
功率 Power:	1700W
电流 Current:	42.5A
行走速度 Speed:	1.5~3.5km/h
清洁宽度 Cleaning width:	510mm/20inch
清洁效率 Cleaning rate:	765~1785m ² /h
驱动电机 Driving motor:	24V 450W 7.5A
刷地电机 Floor motor:	24V 550W 10A
刷地转速 Brush rotation speed:	180RPM
吸水电机 Water sucker motor:	24V 600W 22A
吸力 Sucking degree:	180mbar
增压泵 Pressure pump:	24V 3L/min 3A 100W
吸水扒宽度 Water sucker:	850MM
电池组 Battery:	3×8V 150AH
充电时间 Charge time:	8-12Hour
电瓶使用时间 Hours time:	3.5Hour
清水箱容量 Clean water tank capacity:	50L
污水箱容量 Dirty water tank capacity:	44L
净重 Net weight:	275kg
毛重 Gross weight:	312kg
包装尺寸(含地台板) Packing Size (With Pallet):	1550×720×1210mm
颜色 Colour:	■

产品特点

- 每小时可清洁 765平方米 -1785 平方米。
- 50 升大容量水箱，适合各种大型场地使用。
- 电池单次充电可使用 3.5 小时，质量好，寿命长。

Features

- It can clean 765square meters - 1785 square meters per hour.
- 50 litres of large-capacity water tank, suitable for all kinds of large site use.
- A single battery charge can use 3.5 hours, good quality, long service life.

随机配件 Contents



20" 刷盘
20" brush



20" 针座
20" pad holder



优质充电器
Charger



优质蓄电池
Battery

SC-450

电线式 自动扶梯清洁机 Cable Escalator Cleaner



当自动扶梯向上运行时，机器放置在扶梯的上方清洁。

In cleaning operation, if the escalator goes up, the cleaner should be placed on the upper part of the escalator.



当自动扶梯向下运行时，机器放置在扶梯的下方清洁。

In cleaning operation, if the escalator goes down, the cleaner should be placed on the lower part of the escalator.



性能优点/Specification



前移动轮
 Front movable wheel



布尘袋
 The cloth bag

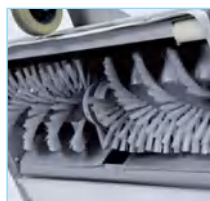

滚刷
 Rolling brush



进口马达
 Imported motor

技术参数 Technical Data

	SC-450
电压 Voltage:	220-240V/50Hz
总功率 Power:	1180W
工作宽度 Operating width:	450mm
吸尘电机 Dry motor:	220V/1000W
滚刷电机 Roll brush motor:	24V/180W
滚刷转速 Roll brush speed:	230RPM
容量 Capacity:	20L
电源线 Cable:	12m
重量 Weight:	39kg
毛重 Gross weight:	42.5kg
包装规格 Packing:	950×540×310mm
绝缘等级 In sulation grade:	I 级

产品特点

- 独特前轮设计，行走更方便！
- 内置集尘袋，取放卫生方便！
- 自动调节滚刷高度，清洁效率高！

Features

- Unique front wheel design, it is more convenient to walk!
- Can set up the dust bag inside, easy and clean.
- Automatically adjust the height of roller, high cleaning efficiency!

SC730ZQ

蒸汽地毯抽洗机 Steam Carpet Cleaner

专利产品

Patented product

专利申请号: 201520631442.6

Patent application number: 201520631442.6



性能优点/Specification



污水箱水位控制器
The Sewage tank
water level controller



蒸汽发热功能
Steam heating function



冷热出水口
Cold and hot water outlet



窗帘吸扒 (可选配)
Curtain Sucker
(optional)

产品特点

- 一体形小、机器本身易清洁。
- 内有清水过滤网避免堵塞。
- 既能独立吸尘、吸水,又能窗帘、地毯清洁;
- 蒸汽、擦洗、吸干多功能集于一体;
- 蒸汽源头125°,高温杀菌;
- 蒸汽配件多样,适合不同环境清洗作业;

Features

- Small size, the machine itself is more easy for cleaning.
- A water filter to avoid congestion.
- It can not only dry & wet vacuum independently, but also clean curtains & carpets;
- Steaming, washing & drying are integrated in one machine.
- Steam source is 125°,high temperature sterilization of different types of sofa fabrics.
- Various steam accessories are suitable for cleaning operations in different environments.

① 地毯吸水钢扒连接软管总承
Carpet water sucker Connecting
hose main bearing

② 吸水扒
Water sucker

③ 长扁扒
Long flat vacuuming head

④ 圆毛刷
Round brush

⑤ 地板刷
Floor brush

⑥ 玻璃刷
Glass brush

⑦ 喷枪
Spraying gun

⑧ 地板刷连接头
Floor brush connector

⑨ 转换头
Converting head

⑩ 高压喷咀
High pressure nozzle

⑪ 圆刷
Small round brush

⑫ 大圆刷
Big round brush

⑬ 蒸汽吸扒
Steam vacuum head

⑭ 加长杆
Extension rod

⑮ 蒸汽管3m
Steam pipe 3m

技术参数 Technical Data

	SC730ZQ
电压 Voltage:	220-240V/50Hz
总功率 Power:	2862W
总电流 Current:	15A
清水箱容量 Clean water tank capacity:	16L
污水箱容量 Dirty water tank capacity:	12L
蒸汽加热器功率 Steam heater power:	2000W
水泵功率 Power of water pump:	34W/28W
吸水电机功率 Power of vacuum motor:	800W
喷水连接管长度 Spraying connecting pipe:	4m
伸缩管长度 Extension tube:	1.5m
配件直径 Hose diameter:	Φ40mm
电源线长度 Cable:	8m
净重 Net weight:	26kg
毛重 Gross weight:	30kg
尺寸 Size:	740×400×630mm
颜色 Colour:	

随机配件 Contents



SC730SF

地毯沙发清洗机

Carpet & Sofa Cleaner



专利产品

Patented product

专利申请号: 201520631442.6

Patent application number: 201520631442.6

性能优点/Specification



污水箱水位控制器
The Sewage tank
water level controller



进口吸水马达
Imported suction motor



窗帘吸扒 (可选配)
Curtain Sucker
(optional)



沙发磨头
Grinding head

产品特点

- 体积小、机器本身易清洁。
- 内有清水过滤网避免堵塞。
- 磨头内采用无刷电机，静音、耐用。
- 窗帘吸扒，一机多能，免却窗帘或沙发套的拆卸，水雾清洗，瞬间吸干。

Features

- Small size, the machine itself is more easy for cleaning.
- A water filter to avoid congestion.
- Grinding head adopts brushless motor, lower-noise, durable.
- Curtain sucker multifunctional in one machine, very convenient, no need to remove the curtain or sofa cover in washing, wash with water mist and dry in short-time.

随机配件 Contents

①地毯吸水钢扒连接软管总承
Carpet water sucker Connecting
hose main bearing

②长扁扒
Long flat vacuuming head

③圆毛刷
Round brush

④吸水扒
Water sucker

⑤沙发磨头
Grinding head

技术参数 Technical Data

	SC730SF
电压 Voltage:	220-240V/50Hz
功率 Power:	1079W
清水箱容量 Clean water tank capacity:	16L
污水箱容量 Dirty water tank capacity:	12L
伸缩管长度 Extension tube:	1.5m
电源线长度 Cable:	8m
水泵功率 Power of water pump:	34W
吸水电机功率 Power of vacuum motor:	1000W
配件直径 Hose diameter:	Φ40mm
净重 Net weight:	29.8kg
毛重 Gross weight:	31.7kg
尺寸 Size:	740×400×630mm
磨头电压 Grinding head voltage:	12V
磨头电机 Grinding head motor:	45W
底盘直径 Brush diameter:	125mm
压力 Pressures	87PSI
颜色 Colour:	



SC730A

地毯抽洗机

Carpet Cleaner



专利产品

Patented product

专利申请号: 201520631442.6

Patent application number: 201520631442.6

性能优点/Specification



污水箱水位控制器
The Sewage tank
water level controller



进口吸水马达
Imported suction motor



窗帘吸扒 (可选配)
Curtain Sucker
(optional)

技术参数 Technical Data

	SC730A
电压 Voltage:	220V/50Hz
功率 Power:	1034W
清水箱容量 Clean water tank capacity:	16L
污水箱容量 Dirty water tank capacity:	12L
伸缩管长度 Extension tube:	1.5m
电源线长度 Cable:	8m
净重 Net weight:	26kg
毛重 Gross weight:	27.5kg
尺寸 Size:	740×400×570mm
颜色 Colour:	

产品特点

- 体积小、机器本身易清洁。
- 内有清水过滤网避免堵塞。
- 无滤网耗材，使用方便成本更低。
- 窗帘吸扒，一机多能，免却窗帘或沙发套的拆卸，水雾清洗，瞬间吸干。

Features

- Small size, the machine itself is more easy for cleaning
- A water filter to avoid congestion.
- without easy consume filtering material, easy to use and lower cost.
- Curtain sucker multifunctional in one machine, very convenient, no need to remove the curtain or sofa cover in washing, wash with water mist and 80%dry in short-time.

随机配件 Contents



小吸水扒
Water sucker



沙发扒头
Sofa vacuuming
head



沙发机长接头
Sofa cleaner
long connector



圆毛刷
Round brush



长扁扒
Long flat
vacuuming head



大钢扒
Large stainless sucker

SC730

三合一沙发清洗机

Three-in-one Sofa Cleaner



专利产品

Patented product

专利申请号: 201520631442.6

Patent application number: 201520631442.6

性能优点/Specification



沙发磨头
Grinding head



污水箱水位控制器
The Sewage tank
water level controller



进口吸水马达
Imported suction motor



水扒水量控制孔
Water sucker control
hole

产品特点

- 体积小、机器本身易清洁。
- 内有清水过滤网避免堵塞。
- 磨头内采用无刷电机，静音、耐用。

Features

- Small size, the machine itself is more easy for cleaning.
- A water filter to avoid congestion.
- Grinding head adopts brushless motor, lower-noise, durable.

随机配件 Contents



磨头
Grinding head



沙发扒头
Sofa vacuuming head



吸水扒
Water sucker



圆毛刷
Round brush



长扁扒
Long flat
vacuuming head

技术参数 Technical Data

	SC730
电压 Voltage:	220-240V/50Hz
功率 Power:	1079W
清水箱容量 Clean water tank capacity:	16L
污水箱容量 Dirty water tank capacity:	12L
伸缩管长度 Extension tube:	1.5m
电源线长度 Cable:	8m
净重 Net weight:	29.8kg
毛重 Gross weight:	31.7kg
尺寸 Size:	740×400×630mm
磨头电压 Grinding head voltage:	12V
磨头电机 Grinding head motor:	45W
底盘直径 Brush diameter:	125mm
压力 Pressures	87PSI
颜色 Colour:	

要选好质量 还是超洁亮

Super Clean Super Qualify

Brushing
Machine Series

刷地机
系列产品

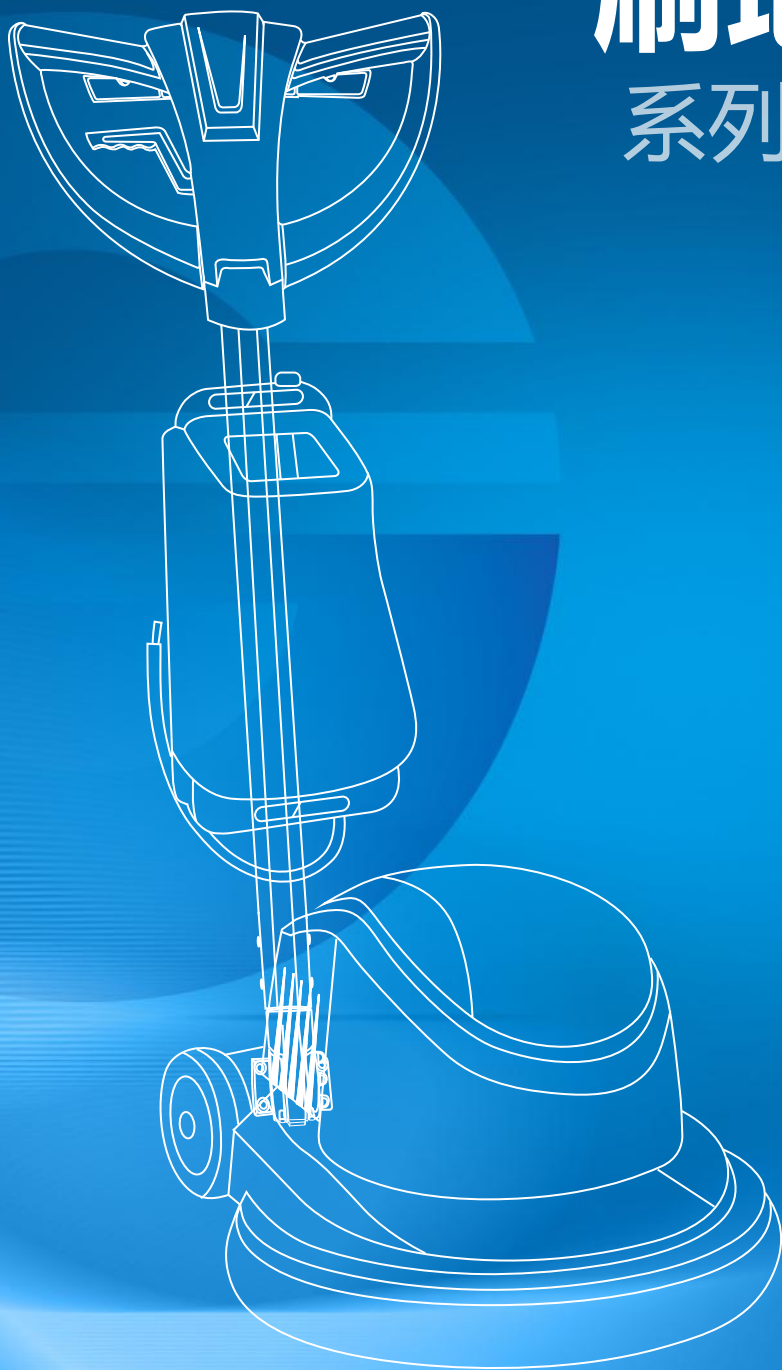

多功能清洗机

Multi-functional Floor Grinding Machine

SC-008

产品特点

- 平稳往复直线运动，打磨、抛光，无死角！
- 工作效率高是旋转式机器的2倍以上。
- 适合各种台阶地面的清洗、抛光、打蜡保养和深度翻新

Features

- Reciprocating linear motion, very stable to grinding or polishing, no blind angle!
- The work efficiency is 2 times of the rotational machine.
- It is especially suitable for various steps floors and marble of cleaning, polishing, wax maintaining and depth renovating.



随机配件 Contents



钻石打磨碟 (可选配)

Diamond grinding disc is applicable (Optional)

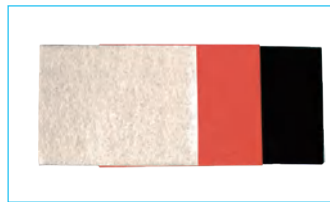

百洁垫 (细、中、粗)

Cleaning pad (Fine/Middle/Coarse)

技术参数 Technical Data

SC-008	
电压 Voltage:	220V ~ /50Hz
功率 Power:	1500W
电流 Current:	9.1A
转速 Speed of rotation:	2834 r/min
运行电容 Operating capacitor:	30μF/500V
启动电容 Start capacitor:	150μF/300V
噪音 Noise:	≤ 75dB
电源线长 Length of power cable:	12m
底盘直径 Base disc size:	480×330mm
加重铁重量 Weighting iron weight:	8×3.25kg
净重 Net weight:	70kg
整机毛重 Gross weight:	72.2kg
手柄包装尺寸 Handle packing size:	420×100×1115mm
机头包装尺寸 Main body packing size:	555×500×395mm
配置 Accessories:	主机、手柄、水箱、百洁垫、加重铁 main body, handle, water tank, cleaning pad, weighting irons

超洁亮多功能刷机

SUPER CLEAN Multi-functional Brushing Machine

经典牛头手柄
Classic tauren handle



蝴蝶形手柄
Butterfly Handle



SC-002





175 多功能刷机
175 Brushing Machine



SC-005

154 多功能刷机
154 Brushing Machine

技术参数 Technical Data

	SC-002	SC-005
电压 Voltage:	220V-240V	220V-240V
功率 Power:	1100W	1100W
转速 Speed:	175rpm/min	154rpm/min
电源线 Main cable length:	12m	12m
底盘直径 Base plate diameter:	17"	17"
整机毛重 Gross weight:	53.35kg	47.56kg
手柄包装尺寸 Handle packing size:	375×126×1133mm	375×126×1133mm
机头包装尺寸 Main body packing size:	540×440×375mm	540×440×370mm
颜色 Colour:		  
配置 Accessories:	主机、手柄、水箱、针座、地刷、毯刷 main body, handle, water tank, pad holder, hard brush, soft brush.	

产品特点

- 特大功率风冷式马达，双电容配置。
- 工作更安全可靠，强劲动力输出。
- 集清洗地毯、地面、起蜡、低速抛光等多功能于一身。

Features

- It is designed with super double- capacitor and high power air-cooling motor.
- More safer operation and more strong power output provided.
- It has multiple functions such as carpet and floor cleaning, wax removing, low-speed polishing, crystal, treatment.

偏头刷地机

Multi-functional Brushing Machine

SC-006

产品特点

- 上水箱卡扣带挂线钩，方便电线收放。
- 内藏式加重铁，降低了主机重心，整机工作稳定。
- 主机整体重心偏左，抵消主机转动时的甩动力量。工作更平稳。

Features

- The humanized design, easy to operate!
- The built-in iron , which is installed under of the base .make for the machine stable and more convenient,more beautiful.
- Main body gravity to the left, which offset the shaking of motor force.So the machine works more smoothly and better control.

随机配件 Contents



17" 地刷
17" hard brush



17" 毯刷
17" soft brush



17" 针座
17" Pad holder



17" 带动盘
17" driving disk

加重铁 15kg
weighting irons



技术参数 Technical Data

	SC-006
电压 Voltage:	220V ~ /50Hz
功率 Power:	1500W
电流 Current:	9.1 A
转速 Speed of rotation:	149 rpm/min
运行电容 Operating capacitor:	20μF/450V.AC
启动电容 Start capacitor:	150μF/250V.AC
噪音 Noise:	≤ 54dB
电源线长 Length of power cable:	12m
刷盘直径 Brush diameter:	17"
机头重量 Weight of The main body:	37kg
整机毛重 Gross weight:	63.6kg
手柄包装尺寸 Handle packing size:	465×120×1140mm
机头包装尺寸 Main body packing size:	580×480×380mm
配置 Accessories:	主机、手柄、水箱、针座、地刷、毯刷、带动盘、加重铁 main body, handle, water tank, pad holder, hard brush, soft brush, driving disk, weighting irons

13寸擦地机 (楼梯机)

13" Brushing Machine (Stair Cleaning Machine)

SC13

产品特点

- 风冷式马达，双电容配置。
- 外型精致小巧，适合于使用小面积地方或者楼梯清洁。

Features

- Air-cooled motor, double capacitor configuration.
- Appearance delicate and cabinet, suitable for use or small area clean stairs.

随机配件 Contents



13" 地刷
13" hard brush



13" 毯刷
13" soft brush



13" 针座
13" pad holder



技术参数 Technical Data

SC13	
电压 Voltage:	220V ~ /50Hz
功率 Power:	750W
电流 Current:	4.8A
转速 Speed of rotation:	175rpm/min
电源线长 Length of power cable:	12m
底盘直径 Base disc size:	13"
机头净重 Net weight of head:	24.5kg
机头毛重 Gross weight of head:	27.5kg
手柄包装尺寸 Handle packing size:	375×126×1133mm
机头包装尺寸 Main body packing size:	450×350×295mm
配置 Accessories:	主机、手柄、水箱、地刷、毯刷、针座 main body, handle, water tank, hard brush, soft brush, pad holder

多功能刷地机

Multi-functional Brushing Machine

蝴蝶形手柄
Butterfly Handle

经典BDA手柄
Classic BDA handle



BD1A



BD2A



BD3A



产品特点

- 特大功率风冷式马达，双电容配置。
- 工作更安全可靠，强劲动力输出。
- 集清洗地毯、地面、起蜡、低速抛光等多功能于一身。

Features

- It is designed with super double- capacitor and high power air-cooling motor.
- More safer operation and more strong power output provided.
- In has multiple functions such as carpet and floor cleaning, wax removing, low-speed polishing, crystal, treatment.

技术参数 Technical Data

	BD1A	BD2A	BD3A
电压 / 频率 Voltage/Frequency:	220V/50Hz	220V/50Hz	220V/50Hz
功率 Power:	1100W	1100W	1100W
电流 Current:	6.92A	6.92A	6.92A
刷盘转速 Brush rotation speed:	154rpm/min	154rpm/min	154rpm/min
噪音 Noise:	≤ 54dB	≤ 54dB	≤ 54dB
刷盘直径 Brush diameter:	17"	17"	17"
电源线 Main cable length:	12m	12m	12m
机头重量 Weight of the main body:	33kg	31.7kg	33kg
整机毛重 Gross weight:	49.66kg	48.36kg	49.66kg
手柄包装尺寸 Handle packing size:	400×120×1140mm	400×120×1140mm	400×120×1140mm
机头包装尺寸 Main body packing size:	540×440×365mm	540×440×390mm	540×440×390mm
颜色 Colour:			
配置 Accessories:	主机、手柄、水箱、针座、地刷、毯刷 main body, handle, water tank, pad holder, hard brush, soft brush.		

加重翻新机

Floor Renewing Machine

蝴蝶形手柄
Butterfly Handle

BD1AE

BD2AE



经典牛头手柄
Classic tauren handle

SC-004



技术参数 Technical Data

	BD1AE	BD2AE	SC-004
电压 / 频率 Voltage/Frequency:	220V/50Hz	220V-240V/50Hz	220V-240V/50Hz
功率 Power:	1500W	1500W	1500W/1800W
刷盘转速 Brush rotation speed:	154rpm/min	154rpm/min	154rpm/min
噪音 Noise:	≤ 54dB	≤ 54dB	≤ 54dB
底盘直径 Base plate diameter:	17"	17"	17"
电源线 Main cable length:	12m	12m	12m
机头重量 Weight of the main body:	33kg	33kg	34.2kg/38.8kg
整机毛重 Gross weight:	72.2kg	72.56kg	73.66kg/78.26kg
加重铁重量 Weighting iron weight:	1×12.8kg	1×14.5kg	1×14.5kg
手柄包装尺寸 Handle packing size:	400×120×1140mm	400×120×1140mm	375×126×1133mm
机头包装尺寸 Main body packing size:	540×440×365mm	540×440×390mm	540×440×370mm
颜色 Colour:	可来样选配Optional	可来样选配Optional	可来样选配Optional
配置 Accessories:	主机、手柄、水箱、针座、地刷、毯刷、加重铁1块、带动盘 main body, handle, water tank, pad holder, hard brush, soft brush, weighting irons one piece, driving disk		



BD1AE 加重铁
Weighting iron



BD2AE/SC-004 加重铁
Weighting iron

产品特点

- 特大功率风冷式马达，双电容配置。
- 工作更安全可靠，强劲动力输出。
- 可洗地毯、地面、起蜡、低速抛光、晶面处理、翻新等。

Features

- It is designed with super double- capacitor and high power air-cooling motor.
- More safer operation and more strong power output provided.
- It has multiple functions such as carpet and floor cleaning, wax removing, low-speed polishing, floor crystal treatment and renewing.

多功能刷机

Multi-functional Brushing Machine



角度调节部位可升级为滑槽卡板,更流畅的控制、更稳定的操作体验。

Angle adjusting parts can be upgraded to sliding card board, more fluid control, more stable operation experience.

经典铁手柄
Classic iron handle



A-039
多功能刷机
Brushing Machine

蝴蝶形手柄
Butterfly Handle



A-041
多功能刷机
Brushing Machine

产品特点

- 特大功率风冷式马达, 双电容配置。
- 工作更安全可靠, 强劲动力输出。
- 集清洗地毯、地面、起蜡、低速抛光等多功能于一身。

Features

- It is designed with super double- capacitor and high power air-cooling motor.
- More safer operation and more strong power output provided.
- It has multiple functions such as carpet and floor cleaning, wax removing, low-speed polishing, crystal, treatment.

技术参数 Technical Data

	A-039	A-041
电压 Voltage:	220V-240V	220V-240V
功率 Power:	1100W	1100W
转速 Speed:	175rpm/min	154rpm/min
电源线 Main cable length:	12m	12m
底盘直径 Base plate diameter:	18"	18"
整机毛重 Gross weight:	60.2kg	58.15kg
手柄包装尺寸 Handle packing size:	420×100×1115mm	420×100×1115mm
机头包装尺寸 Main body packing size:	590×450×370mm	600×450×370mm
配置 Accessories:	主机、手柄、水箱、针座、地刷、毯刷 main body, handle, water tank, pad holder, hard brush, soft brush.	

行星盘加重铁翻新机

Epicyclic Disk Weighting Renewing Machine

A-042



角度调节部位可升级为滑槽卡板,更流畅的控制、更稳定的操作体验。

Angle adjusting parts can be upgraded to sliding card board, more fluid control, more stable operation experience.



加重铁
Weighting iron



行星盘
Epicyclic disk



底盘
Base plate

产品特点

- 特大功率风冷式马达, 双电容配置。
- 传动部分采用硬质工程塑料行星齿轮。
- 可洗地毯、地面、起蜡、低速抛光、晶面处理、翻新等。

Features

- It is designed with super double-capacitor and high power air-cooling motor.
- Its driving parts are the triple epicyclic gears made of hard engineering plastic.
- It has multiple functions such as carpet and floor cleaning, wax removing, low-speed polishing, floor crystal treatment and renewing.

蝴蝶形手柄
Butterfly Handle

经典铁手柄
Classic iron handle



技术参数 Technical Data

	A-042
电压 Voltage:	220V-240V
功率 Power:	1800W
主盘转速 Main disk rotation speed:	154rpm/min
磨头转速 Polishing head rotation speed:	1280rpm
电源线 Main cable length:	12m
底盘直径 Base plate diameter:	18"
整机毛重 Gross weight:	99.7kg
加重铁重量 Weighting iron weight:	2×20kg
磨头数量 Number of polishing heads:	3ps
铁手柄包装尺寸 Iron handle package size:	420×100×1115mm
蝴蝶手柄包装尺寸 Butterfly Handle Package Size:	465×120×1140mm
机头包装尺寸 Main body packing size:	600×450×370mm
配置 Accessories:	主机、手柄、水箱、针座、地刷、毯刷、加重铁(2块)、带动盘、行星盘 main body, handle, water tank, pad holder, hard brush, soft brush, weighting irons(2), driving disk, epicyclic disks

高速抛光机

High-speed Burnisher

SC-1500

蝴蝶形手柄
Butterfly Handle



经典牛头手柄
Classic tauren handle

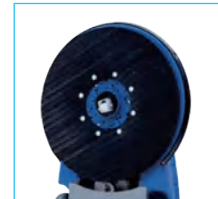

20" 针座
20" Pad holder

技术参数 Technical Data

	SC-1500
电压 Voltage:	220V-240V
功率 Power:	1500W
转速 Speed:	1500rpm
电源线 Main cable length:	12m
底盘直径 Base plate diameter:	20"
牛头手柄整机毛重 Gross weight with tauren handle:	49.8kg
蝴蝶手柄整机毛重 Gross weight with butterfly handle:	49.8kg
机头包装尺寸 Main body packing size:	860×550×480mm
BD手柄包装尺寸 Tauren handle packing size:	400×120×930mm
牛头手柄包装尺寸 Tauren handle packing size:	375×126×910mm
蝴蝶手柄包装尺寸 Butterfly handle packing size:	465×120×930mm
配置 Accessories:	主机、手柄、针座 main body, handle pad holder

产品特点

- 外观设计灵巧精美，操作灵便。
- 上蜡后经抛光处理，地面光亮如镜。
- 专为抛光各类石质地面而设，每分钟转速高达1500转。

Features

- It has a beautiful and fashionable appearance and is easy to operate.
- After waxing for polishing the floor surface is shining as a mirror.
- It is designed for polishing the floor of all kinds of stone materials speed is 1500 rpm the motor is totally enclosed.

要选好质量 还是超洁亮

Super Clean Super Quality

LIGHT CLEAN
CARPET & SOFA CLEANER

地毯沙发抽洗机

系列产品

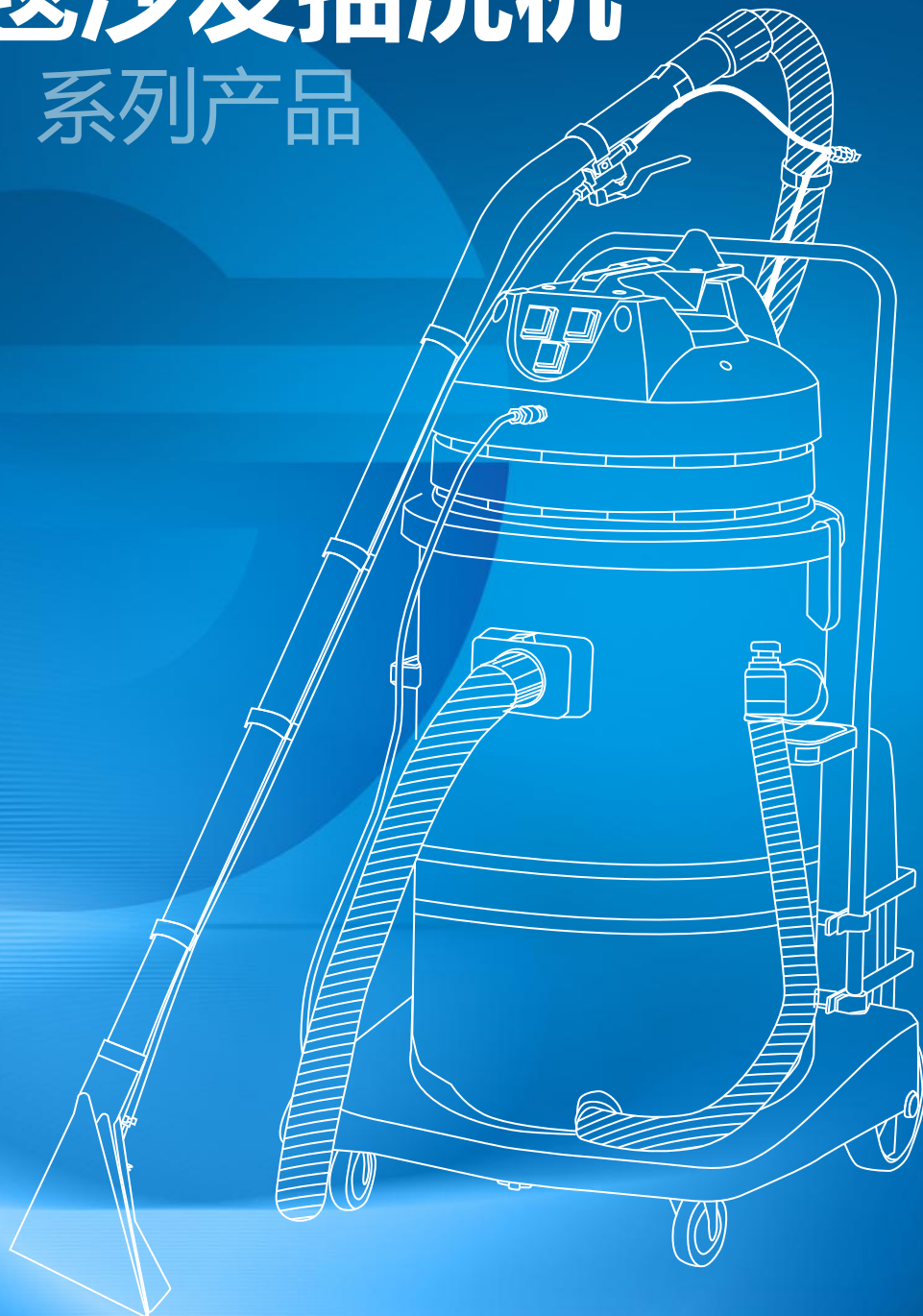



窗帘吸扒 (可选配)
Curtain Sucker (optional)



LC-30SE

四合一蒸汽沙发机 Four-in-One Steam Sofa Cleaner

技术参数 Technical Data

LC-30SE

功能 Function:	蒸汽沙发机 Steam Sofa Cleaner
主机容量 Capacity:	30L
清水箱容量 Clean Water Capacity:	25L
蒸汽水箱容量 Steam Water Capacity:	2.1L
总功率 Power:	2925W
电压 Voltage:	220V-240V
抽洗水泵功率 Suction Power of water pump:	34W
蒸汽水泵功率 Steam Power of water pump:	28W
吸水电机功率 Power of vacuum motor:	800W
蒸汽加热器功率 Steam heater power:	2000W
磨头电机 Grinding head motor	45W
气泵功率 Air pump	15W
高度 Height:	860mm
桶身直径 Tank diameter:	Φ375mm
冷却模式 Mode of cooling:	循环风冷 Circulating air cooling
气流量 Air flow rate:	53L/S
真空吸力 Vacuum suction:	170mbar
电源线长 Length of the cable:	8m
配件直径 Hose diameter:	Φ40mm
包装规格 Packing:	628x430x970 mm
净重 Net weight:	27.5kg
毛重 Gross weight:	30kg
压力 Pressures	87PSI
颜色 Colour:	
配件包装规格 Accessory Packaging Specification:	1490x220x170 mm
配件毛重 Accessory Gross Weight:	8.24kg

随机配件/Contents

① 地毯吸水钢扒连接软管总承 Carpet water sucker Connecting hose main bearing	⑥ 圆毛刷 Round brush	⑫ 转换头 Converting head	⑮ 蒸汽管3m Steam pipe 3m
② 吸水扒 Water sucker	⑦ 弯钢管 Curved steel pipe	⑬ 高压喷嘴 High pressure nozzle	⑰ 沙发磨头 Grinding head
③ 尘扒 Dust vacuuming head	⑧ 地板刷 Floor brush	⑭ 圆刷 Small round brush	⑱ 尘袋 Dust bag
④ 水扒 Water vacuuming head	⑨ 玻璃刷 Glass brush	⑰ 蒸汽吸扒 Steam vacuum head	⑳ 量杯 Measuring cup
⑤ 长扁扒 Long flat vacuuming head	⑩ 喷枪 Spraying gun	⑰ 加长杆 Extension rod	㉑ 毛巾 Towel
	⑪ 地板刷连接头 Floor brush connector	⑰ 大圆刷 Big round brush	㉒ 漏洞 funnel

产品特点/Features

- 滚塑一体成型机身，坚固耐用
- 配备强劲静音型马达，吸力特强
- 既能独立吸尘、吸水，又能窗帘、地毯清洁；
- 蒸汽、擦洗、吸干多功能集于一体；
- 蒸汽源头125°，高温杀菌；
- 蒸汽配件多样，适合不同环境清洗作业；
- Machine is strong and durable.
- With a powerful lower-noise motor the vacuum cleaner has a special strong suction.
- It can not only dry & wet vacuum independently, but also clean curtains & carpets;
- Steaming, washing & drying are integrated in one machine.
- Steam source is 125° ,high temperature sterilization of different types of sofa fabrics.
- Various steam accessories are suitable for cleaning operations in different environments.



蒸汽模式
Steam Mode



吸尘吸水模式
Vacuum Mode



沙发磨头模式
Sofa grinding head Mode

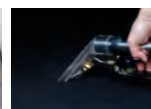

吸扒模式
Sucking Mode



背面喷咀图
Rear nozzle diagram





窗帘吸扒 (可选配)
Curtain Sucker (optional)



LC-30SE-T

三合一沙发机

Three-in-one carpet sofa cleaner

技术参数 Technical Data

	LC-30SE-T
功能 Function:	地毯沙发机 Carpet Cleaning & Sofa Cleaning
主机容量 Capacity:	30L
清水箱容量 Clean Water Capacity:	25L
沙发磨头水箱容量 Steam Water Capacity:	2.1L
总功率 Power:	1925W
电压 Voltage:	220V-240V
抽洗水泵功率 Suction Power of water pump:	34W
制泡水泵功率 Bubble water pump power:	28W
吸水电机功率 Power of vacuum motor:	1800W
磨头电机 Grinding head motor	45W
气泵功率 Air pump	15W
高度 Height:	860mm
桶身直径 Tank diameter:	Φ375mm
冷却模式 Mode of cooling:	循环风冷 Circulating air cooling
气流量 Air flow rate:	53L/S
真空吸力 Vacuum suction:	230mbar
电源线长 Length of the cable:	8m
配件直径 Hose diameter:	Φ40mm
包装规格 Packing:	628x430x970 mm
净重 Net weight:	26.5kg
毛重 Gross weight:	29kg
压力 Pressures	87PSI
颜色 Colour:	
配件包装规格 Accessory Packaging Specification:	1490x220x170 mm
配件毛重 Accessory Gross Weight:	7.94kg

随机配件/Contents

- | | | |
|--|-----------------------------------|----------------------------|
| ① 地毯吸水钢扒连接软管总承
Carpet water sucker Connecting hose main bearing | ⑤ 长扁扒
Long flat vacuuming head | ⑦ 弯钢管
Curved steel pipe |
| ② 吸水扒
Water sucker | ⑥ 圆毛刷
Round brush | ⑧ 沙发磨头
Grinding head |
| ③ 尘扒
Dust vacuuming head | ④ 水扒
Water vacuuming head | ⑨ 尘袋
Dust bag |

产品特点/Features

- 滚塑一体成型机身, 坚固耐用
 - 配备强劲静音型马达, 吸力特强
 - 既能独立吸尘、吸水, 又能窗帘、地毯清洁;
 - 擦洗、吸干多功能集于一体;
 - 配件多样, 适合不同环境清洗作业;
- Machine is strong and durable.
 - With a powerful lower-noise motor the vacuum cleaner has a special strong suction.
 - It can not only dry & wet vacuum independently, but also clean curtains & carpets;
 - Steaming, washing & drying are integrated in one machine.
 - Various accessories are suitable for cleaning operations in different environments.



吸尘吸水模式
Vacuum Mode



沙发磨头模式
Sofa grinding head Mode



吸扒模式
Sucking Mode



亮洁牌蒸汽地毯抽洗机

Steam Carpet Cleaner



背面水箱图
Rear Water Tank Diagram

技术参数 Technical Data	LC-15ZQ	LC-20ZQ	LC-30ZQ	LC-40ZQ
功能 Function:	蒸汽地毯抽洗机 Steam Carpet cleaner	蒸汽地毯抽洗机 Steam Carpet cleaner	蒸汽地毯抽洗机 Steam Carpet cleaner	蒸汽地毯抽洗机 Steam Carpet cleaner
主机容量 Capacity:	15L	20L	30L	40L
蒸汽水箱容量 Steam water tank capacity:	3L	3L	3L	3L
清水箱容量 Clean Water Capacity:	5L	7L	7L	7L
总功率 Power:	2862W	2862W	2862W	2862W
电压 Voltage:	220V-240V	220V-240V	220V-240V	220V-240V
水泵功率 Power of water pump:	34W/28W	34W/28W	34W/28W	34W/28W
吸水电机功率 Power of vacuum motor:	800W	800W	800W	800W
蒸汽加热器功率 Steam heater power:	2000W	2000W	2000W	2000W
高度 Height:	620mm	720mm	830mm	890mm
桶身直径 Tank diameter:	Φ335mm	Φ335mm	Φ335mm	Φ335mm
冷却模式 Mode of cooling:	循环风冷 Circulating air cooling	循环风冷 Circulating air cooling	循环风冷 Circulating air cooling	循环风冷 Circulating air cooling
气流量 Air flow rate:	48L/S	53L/S	53L/S	53L/S
真空吸力 Vacuum suction:	170mbar	170mbar	170mbar	170mbar
电源线长 Length of the cable:	8m	8m	8m	8m
配件直径 Hose diameter:	Φ40mm	Φ40mm	Φ40mm	Φ40mm
包装规格 Packing:	445×410×650mm	455×410×755mm	455×410×855mm	455×410×920mm
净重 Net weight:	15.83kg	17.5kg	18.8kg	19.8kg
毛重 Gross weight:	17.4kg	19.3kg	20.63kg	21.54kg
压力 Pressures	87PSI	87PSI	87PSI	87PSI
颜色 Colour:	■	■	■	■
配件包装规格 Accessory Packaging Specification:	1490×220×170 mm			
配件毛重 Accessory Gross Weight:	5kg			

产品特点/Features

- 圆桶型不锈钢桶身, 坚固耐用
- 配备强劲静音型马达, 吸力特强
- 既能独立吸尘、吸水, 又能窗帘、地毯清洁;
- 蒸汽、擦洗、吸干多功能集于一体;
- 蒸汽源头125°, 高温杀菌;
- 蒸汽配件多样, 适合不同环境清洗作业;
- The stainless tank is strong and durable.
- With a powerful lower-noise motor the vacuum cleaner has a special strong suction.
- It can not only dry & wet vacuum independently, but also clean curtains & carpets;
- Steaming, washing & drying are integrated in one machine.
- Steam source is 125°, high temperature sterilization of different types of sofa fabrics.
- Various steam accessories are suitable for cleaning operations in different environments.



窗帘吸扒 (可选配)
Curtain Sucker (optional)

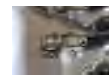

背面喷嘴图
Rear nozzle diagram



随机配件/Contents

- ① 地毯吸水钢扒连接软管总承
Carpet water sucker Connecting hose main bearing
- ② 吸水扒
Water sucker
- ③ 尘扒
Dust vacuuming head
- ④ 水扒
Water vacuuming head
- ⑤ 长扁扒
Long flat vacuuming head

- ⑥ 圆毛刷
Round brush
- ⑦ 弯钢管
Curved steel pipe
- ⑧ 地板刷
Floor brush
- ⑨ 玻璃刷
Glass brush
- ⑩ 喷枪
Spraying gun
- ⑪ 地板刷连接器
Floor brush connector

- ⑫ 转换头
Converting head
- ⑬ 高压喷嘴
High pressure nozzle
- ⑭ 圆刷
Small round brush
- ⑮ 蒸汽吸扒
Steam vacuum head
- ⑯ 加长杆
Extension rod
- ⑰ 大圆刷
Big round brush

- ⑱ 蒸汽管3m
Steam pipe 3m
- ⑳ 量杯
Measuring cup
- ㉑ 毛巾
Towel
- ㉒ 漏洞漏斗
Leakage funnel

亮洁牌多功能地毯沙发抽洗机

Multi-functional Carpet & Sofa Cleaner

LC-20SF

20升 (20L)



LC-30SF

30升 (30L)



LC-40SF

40升 (40L)



①地毯吸水钢扒连接软管总承
Carpet water sucker Connecting
hose main bearing
②水扒
Water vacuuming head
③尘扒
Dust vacuuming head

④长扁扒
Long flat vacuuming head
⑤圆毛刷
Round brush
⑥吸水扒
Water sucker

⑦软管
Soft tube
⑧弯钢管
Steel tube
⑨沙发磨头
Grinding head



技术参数 Technical Data

	LC-20SF	LC-30SF	LC-40SF
功能 Function:	地毯沙发抽洗机 Carpet & Sofa cleaner	地毯沙发抽洗机 Carpet & Sofa cleaner	地毯沙发抽洗机 Carpet & Sofa cleaner
主机容量 Capacity:	20L	30L	40L
清水箱容量 Clean Water Capacity:	10L	10L	10L
电压 Voltage:	220V-240V	220V-240V	220V-240V
水泵功率 Power of water pump:	34W	34W	34W
吸水电机功率 Power of vacuum motor:	1000W	1000W	1000W
高度 Height:	720mm	830mm	890mm
桶身直径 Tank diameter:	Φ335mm	Φ335mm	Φ335mm
冷却模式 Mode of cooling:	循环风冷 Circulating air cooling	循环风冷 Circulating air cooling	循环风冷 Circulating air cooling
气流量 Air flow rate:	53L/S	53L/S	53L/S
真空吸力 Vacuum suction:	230mbar	230mbar	230mbar
电源线长 Length of the cable:	7m	7m	7m
配件直径 Hose diameter:	Φ40mm	Φ40mm	Φ40mm
磨头电压 Grinding head voltage:	12V	12V	12V
磨头电机 Grinding head motor:	45W	45W	45W
底盘直径 Brush diameter:	125mm	125mm	125mm
包装规格 Packing:	455×410×755mm	455×410×855mm	455×410×920mm
净重 Net weight:	17.5kg	17.8kg	19.4kg
毛重 Gross weight:	19.3kg	19.6kg	20.4kg
配件毛重 Hose gross weight:	5.2kg	5.2kg	5.2kg
压力 Pressures	87PSI	87PSI	87PSI
颜色 Colour:	■	■	■
配件包装规格 Accessory Packaging Specification:		1490x220x170 mm	
配件毛重 Accessory Gross Weight:		7.94kg	



窗帘吸扒 (可选配)
Curtain Sucker (optional)

产品特点

- 圆桶型不锈钢桶身, 坚固耐用
- 配备强劲静音型马达, 吸力特强
- 新型大轮盘座, 稳重美观
- 随机附件一应俱全

Features

- The stainless tank is strong and durable.
- With a powerful lower-noise motor the vacuum cleaner has a special strong suction.
- New-style large wheel plate. It is stable and beautiful.
- A complete set of accessories are supplied with the vacuum cleaner.

亮洁牌多功能地毯沙发抽洗机

Multi-functional Carpet & Sofa Cleaner



LC-602SF

60升 (60L)

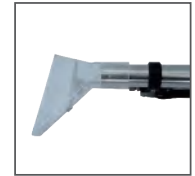

窗帘吸扒 (可选配)
Curtain Sucker (optional)



①地毯吸水钢扒连接软管总承
Carpet water sucker Connecting
hose main bearing
②水扒
Water vacuuming head
③尘扒
Dust vacuuming head

④长扁扒
Long flat vacuuming head
⑤圆毛刷
Round brush
⑥吸水扒
Water sucker

⑦软管
Soft tube
⑧弯钢管
Steel tube
⑨沙发磨头
Grinding head



技术参数 Technical Data

	LC-602SF
功能 Function:	地毯沙发抽洗机 Carpet & Sofa cleaner
主机容量 Capacity:	60L
清水箱容量 Clean Water Capacity:	20L
总功率 Power:	2079W
电压 Voltage:	220V-240V
水泵功率 Power of water pump:	34W
吸水电机功率 Power of vacuum motor:	1000W×2
高度 Height:	940mm
桶身直径 Tank diameter:	Φ440mm
冷却模式 Mode of cooling:	循环风冷 Circulating air cooling
气流量 Air flow rate:	106L/S
真空吸力 Vacuum suction:	250mbar
电源线长 Length of the cable:	8m
配件直径 Hose diameter:	Φ40mm
磨头电压 Grinding head voltage:	12V
磨头电机 Grinding head motor:	45W
底盘直径 Brush diameter:	125mm
包装规格 Packing:	640×540×990mm
净重 Net weight:	31.5kg
毛重 Gross weight:	35.7kg
配件毛重 Hose gross weight:	5.2kg
压力 Pressures	87PSI
颜色 Colour:	■
配件包装规格 Accessory Packaging Specification:	1490x220x170 mm
配件毛重 Accessory Gross Weight:	4.7kg

产品特点

- 圆桶型不锈钢桶身, 坚固耐用
- 配备强劲静音型马达, 吸力特强
- 新型大轮盘座, 稳重美观
- 随机附件一应俱全

Features

- The stainless tank is strong and durable.
- With a powerful lower-noise motor the vacuum cleaner has a special strong suction.
- New-style large wheel plate. It is stable and beautiful.
- A complete set of accessories are supplied with the vacuum cleaner.



亮洁牌地毯抽洗机

LIGHT CLEAN Carpet Cleaner

排污管需要另外选择
Option Sewage Pipe

LC-20SC

20 升 (20L)



LC-30SC

30 升 (30L)



LC-40SC

40 升 (40L)



①地毯吸水钢扒连接软管总承
Carpet water sucker Connecting
hose main bearing
②水扒
Water vacuuming head

③尘扒
Dust vacuuming head

④长扁扒
Long flat vacuuming head

⑤圆毛刷
Round brush

⑥吸水扒
Water sucker

⑦软管
Soft tube

⑧弯钢管
Steel tube



技术参数 Technical Data

	LC-20SC	LC-30SC	LC-40SC
功能 Function:	地毯抽洗机 Carpet cleaner	地毯抽洗机 Carpet cleaner	地毯抽洗机 Carpet cleaner
主机容量 Capacity:	20L	30L	40L
清水箱容量 Clean Water Capacity:	10L	10L	10L
总功率 Power:	1034W	1034W	1034W
电压 Voltage:	220V-240V	220V-240V	220V-240V
水泵功率 Power of water pump:	34W	34W	34W
吸水电机功率 Power of vacuum motor:	1000W	1000W	1000W
高度 Height:	720mm	830mm	890mm
桶身直径 Tank diameter:	Φ335mm	Φ335mm	Φ335mm
冷却模式 Mode of cooling:	循环风冷 Circulating air cooling	循环风冷 Circulating air cooling	循环风冷 Circulating air cooling
气流量 Air flow rate:	53L/S	53L/S	53L/S
真空吸力 Vacuum suction:	230mbar	230mbar	230mbar
电源线长 Length of the cable:	7m	7m	7m
配件直径 Hose diameter:	Φ40mm	Φ40mm	Φ40mm
包装规格 Packing:	455×410×755mm	455×410×855mm	455×410×920mm
净重 Net weight:	15.5kg	15.8kg	17.4kg
毛重 Gross weight:	17.3kg	17.6kg	18.4kg
配件毛重 Hose gross weight:	4.7kg	4.7kg	4.7kg
压力 Pressures	87PSI	87PSI	87PSI
颜色 Colour:	■	■	■
配件包装规格 Accessory Packaging Specification:		1490x220x170 mm	
配件毛重 Accessory Gross Weight:		4.7kg	



窗帘吸扒 (可选配)
Curtain Sucker (optional)

产品特点

- 圆桶型不锈钢桶身, 坚固耐用
- 配备强劲静音型马达, 吸力特强
- 新型大轮盘座, 稳重美观
- 随机附件一应俱全

Features

- The stainless tank is strong and durable.
- With a powerful lower-noise motor the vacuum cleaner has a special strong suction.
- New-style large wheel plate. It is stable and beautiful.
- A complete set of accessories are supplied with the vacuum cleaner.

亮洁牌地毯抽洗机

LIGHT CLEAN Carpet Cleaner

LC-603PC
60升 (60L)

LC-602SC
60升 (60L)

LC-802SC
80升 (80L)

塑料桶
Plastic tank



①地毯吸水钢扒连接软管总承
Carpet water sucker Connecting
hose main bearing
②水扒
Water vacuuming head

③尘扒
Dust vacuuming head
④长扁扒
Long flat vacuuming
head

⑤圆毛刷
Round brush
⑥吸水扒
Water sucker

⑦软管
Soft tube
⑧弯钢管
Steel tube



技术参数 Technical Data

	LC-603PC	LC-602SC	LC-802SC
功能 Function:	地毯抽洗机 Carpet cleaner	地毯抽洗机 Carpet cleaner	地毯抽洗机 Carpet cleaner
主机容量 Capacity:	60L	60L	80L
总功率 Power:	2110W	2110W	2110W
清水箱容量 Clean Water Capacity:	20L	20L	20L
电压 Voltage:	220V-240V	220V-240V	220V-240V
水泵功率 Power of water pump:	110W	110W	110W
吸水电机功率 Power of vacuum motor:	2000W	2000W	2000W
高度 Height:	94cm	94cm	109cm
桶身直径 Tank diameter:	Φ440mm	Φ440mm	Φ440mm
冷却模式 Mode of cooling:	循环风冷 Circulating air cooling	循环风冷 Circulating air cooling	循环风冷 Circulating air cooling
气流量 Air flow rate:	106L/S	106L/S	106L/S
真空吸力 Vacuum suction:	250mbar	250mbar	250mbar
电源线长 Length of the cable:	8m	8m	8m
配件直径 Hose diameter:	Φ40mm	Φ40mm	Φ40mm
包装规格 Packing:	640×540×990mm	640×540×990mm	640×540×1110mm
净重 Net weight:	27.8kg	28.9kg	29.7kg
毛重 Gross weight:	31.1kg	32.2kg	33.2kg
配件毛重 Hose gross weight:	4.7kg	4.7kg	4.7kg
压力 Pressures	116PSI	116PSI	116PSI
颜色 Colour:	塑料桶	不锈钢桶	不锈钢桶
配件包装规格 Accessory Packaging Specification:		1490x220x170 mm	
配件毛重 Accessory Gross Weight:		4.7kg	



窗帘吸扒 (可选配)
Curtain Sucker (optional)

产品特点

- 圆桶型不锈钢桶身/塑料身,坚固耐用
- 配备强劲静音型马达,吸力特强
- 新型大轮盘座,稳重美观
- 随机附件一应俱全

Features

- The stainless or plastic tank is strong and durable.
- With a powerful lower-noise motor the vacuum cleaner has a special strong suction.
- New-style large wheel plate. It is stable and beautiful.
- A complete set of accessories are supplied with the vacuum cleaner.

要选好质量 还是超洁亮

Super Clean Super Qualify

Wet and Dry
Vacuum Cleaner

吸尘吸水机

系列产品

Light Clean

亮洁品牌
LIGHT CLEAN SERIES

Hai Light

海亮品牌
HAI CLEAN SERIES



深海洁品牌
SEA CLEAN SERIES

KIMBO

KIMBO 品牌
KIMBO SERIES



亮洁牌10升超静音型吸尘机

LIGHT CLEAN 10L Super Lower-noise Dry Vacuum Cleaner



内置尘袋
Built-in dust bag

LC-101

产品特点

- 外观设计超前时尚，吸力强劲的进口吸尘电机使它得以长时间不间断操作，完美的隔音设计，最能适应对噪音敏感区域的清洁。

Features

- It has a fashionable appearance. The imported vacuum motor, which has a strong suction, allows a long and uninterrupted operation. The perfect sound insulation design makes it suitable for noise sensitive site. It contains a large capacity wool dust-collecting bag, preventing fine dust from getting out, while keeping a strong suction. The product is compact, light and handy, not taking a large place for storing. It is the best choice cleaner for hotels, rooms office and families.

技术参数 Technical Data

	LC-101
功能 Function:	吸尘 dry
容量 Capacity:	10L
功率 Power:	1000W
电压 Voltage:	220V-240V
高度 Height:	32cm
桶身直径 Tank diameter:	Φ345mm
冷却模式 Mode of cooling:	循环风冷 Circulating air cooling
气流量 Air flow rate:	48L/S
真空吸力 Vacuum suction:	210mbar
电源线长 Length of the cable:	7m
配件直径 Hose diameter:	Φ36mm
包装规格 Packing:	380×380×515mm
净重 Net weight:	9.8kg
毛重 Gross weight:	11.2kg

亮洁牌15升吸尘吸水机

LIGHT CLEAN 15L Wet and Dry Vacuum Cleaner

豪华底座
Luxury base

LC-151

配 1000W 马达
With 1000W Motor

LC-151P

配 1500W 马达
With 1500W Motor



普通底座
Normal base

LC-151N

配 1000W 马达
With 1000W Motor

LC-151NP

配 1500W 马达
With 1500W Motor



连体塑料桶
One-body plastic tank

LC-152

配 1000W 马达
With 1000W Motor

LC-152P

配 1500W 马达
With 1500W Motor



塑料桶
Plastic tank

LC-152N

配 1000W 马达
With 1000W Motor

LC-152NP

配 1500W 马达
With 1500W Motor



技术参数 Technical Data

	LC-151/LC-151P	LC-151N/ LC-151NP	LC-152/ LC-152P	LC-152N/ LC-152NP
功能 Function:	吸尘吸水 wet and dry	吸尘吸水 wet and dry	吸尘吸水 wet and dry	吸尘吸水 wet and dry
容量 Capacity:	15L	15L	15L	15L
功率 Power:	1000W/1500W	1000W/1500W	1000W/1500W	1000W/1500W
电压 Voltage:	220V-240V	220V-240V	220V-240V	220V-240V
高度 Height:	58cm	58cm	58cm	58cm
桶身直径 Tank diameter:	Φ345mm	Φ345mm	Φ345mm	Φ345mm
冷却模式 Mode of cooling:	循环风冷 Circulating air cooling	循环风冷 Circulating air cooling	循环风冷 Circulating air cooling	循环风冷 Circulating air cooling
气流量 Air flow rate:	48L/S	48L/S	48L/S	48L/S
真空吸力 Vacuum suction:	210mbar/220mbar	210mbar/220mbar	210mbar/220mbar	210mbar/220mbar
电源线长 Length of the cable:	7m	7m	7m	7m
配件直径 Hose diameter:	Φ36mm	Φ36mm	Φ36mm	Φ36mm
包装规格 Packing:	438×438×650mm	410×410×640mm	400×400×600mm	410×410×640mm
净重 Net weight:	11.9kg	12.6kg	11kg	11kg
毛重 Gross weight:	13.8kg	14.5kg	12.2kg	12.2kg

产品特点

- 圆桶型不锈钢桶 / 塑料身, 坚固耐用
- 配备强劲静音型 1000W/1500W 马达, 吸力特强
- 新型大轮盘座, 稳重美观
- 随机附件一应俱全

Features

- The stainless or plastic tank is strong and durable.
- With a powerful lower-noise 1000W or 1500W motor the vacuum cleaner has a special strong suction.
- New-style large wheel plate. It is stable and beautiful.
- A complete set of accessories are supplied with the vacuum cleaner.

亮洁牌30升吸尘吸水机

LIGHT CLEAN 30L Wet and Dry Vacuum Cleaner

产品特点

- 圆桶型不锈钢桶身，坚固耐用
- 配备强劲静音型马达，吸力特强
- 新型大轮盘座，稳重美观
- 随机附件一应俱全

Features

- The stainless tank is strong and durable.
- With a powerful lower-noise motor the vacuum cleaner has a special strong suction.
- New-style large wheel plate. It is stable and beautiful.
- A complete set of accessories are supplied with the vacuum cleaner.

豪华底座
Luxury base



LC-301 **LC-301P**
配 1000W 马达 配 1500W 马达
With 1000W Motor With 1500W Motor

普通底座
Normal base



LC-301N **LC-301NP**
配 1000W 马达 配 1500W 马达
With 1000W Motor With 1500W Motor

连体塑料桶
One-body plastic tank

LC-302

配 1000W 马达
With 1000W Motor

LC-302P

配 1500W 马达
With 1500W Motor



产品特点

- 塑料桶身，坚固耐用
- 配备强劲静音型马达，吸力极强
- 新型宽大底座，稳重美观
- 随机附件一应俱全

Features

- The plastic tank is strong and durable
- With a powerful lower-noise motor the vacuum cleaner has a special strong suction.
- New-style large wheel plate. It is stable and beautiful.
- A complete set of accessories are supplied with the vacuum cleaner.

技术参数 Technical Data

	LC-301/LC-301P	LC-301N/LC-301NP	LC-302/LC-302P
功能 Function:	吸尘吸水 wet and dry	吸尘吸水 wet and dry	吸尘吸水 wet and dry
容量 Capacity:	30L	30L	30L
功率 Power:	1000W/1500W	1000W/1500W	1000W/1500W
电压 Voltage:	220V-240V	220V-240V	220V-240V
高度 Height:	76cm	76cm	76cm
桶身直径 Tank diameter:	Φ345mm	Φ345mm	Φ345mm
冷却模式 Mode of cooling:	循环风冷 Circulating air cooling	循环风冷 Circulating air cooling	循环风冷 Circulating air cooling
气流量 Air flow rate:	53L/S	53L/S	53L/S
真空吸力 Vacuum suction:	230mbar/240mbar	230mbar/240mbar	230mbar/240mbar
电源线长 Length of the cable:	7m	7m	7m
配件直径 Hose diameter:	Φ40mm	Φ40mm	Φ40mm
包装规格 Packing:	438×438×825mm	410×410×815mm	400×400×800mm
净重 Net weight:	14.5kg	13.6kg	12.2kg
毛重 Gross weight:	16.2kg	15.6kg	14kg

亮洁牌60升吸尘吸水机

LIGHT CLEAN 60L Wet and Dry Vacuum Cleaner

豪华底座
Luxury base

LC-602S

配 1000W 马达
With 1000W Motor

LC-602SP

配 1500W 马达
With 1500W Motor



千秋架
Tilt

LC-602J

配 1000W 马达
With 1000W Motor

LC-602JP

配 1500W 马达
With 1500W Motor



塑料桶
Plastic tank

LC-603J

配 1000W 马达
With 1000W Motor

LC-603JP

配 1500W 马达
With 1500W Motor



三马达款
Three-motor



LC-602S-3



LC-603J-3



LC-602J-3

技术参数 Technical Data

	LC-602J/LC-602JP /LC-602J-3	LC-602S/LC-602SP /LC-602S-3	LC-603J/LC-603JP /LC-603J-3
功能 Function:	吸尘吸水 wet and dry	吸尘吸水 wet and dry	吸尘吸水 wet and dry
容量 Capacity:	60L	60L	60L
功率 Power:	2000W/3000W/3000W	2000W/3000W/3000W	2000W/3000W/3000W
电压 Voltage:	220V-240V	220V-240V	220V-240V
高度 Height:	97cm	94cm	87cm
桶身直径 Tank diameter:	Φ440mm	Φ440mm	Φ440mm
冷却模式 Mode of cooling:	循环风冷 Circulating air cooling	循环风冷 Circulating air cooling	循环风冷 Circulating air cooling
气流量 Air flow rate:	106L/S 159L/S 159L/S	106L/S 159L/S 159L/S	106L/S 159L/S 159L/S
真空吸力 Vacuum suction:	250mbar	250mbar	250mbar
电源线长 Length of the cable:	8m	8m	8m
配件直径 Hose diameter:	Φ40mm	Φ40mm	Φ40mm
包装规格 Packing:	630×560×1050mm	625×595×1040mm	590×520×995mm
净重 Net weight:	26kg/26kg/27.3kg	32kg/32kg/33.7kg	24.5kg/24.5kg/26.2kg
毛重 Gross weight:	27.2kg/27.2kg/29.5kg	35.5kg/35.5kg/37.2kg	27.5kg/27.5kg/29.2kg

产品特点

- 圆桶型不锈钢桶 / 塑料身，坚固耐用
- 配备强劲静音型马达，吸力特强
- LC-602J 配备千秋架式倒水，使用便捷
- LC-602S 配备新型大轮盘座，稳重美观
- LC-603J 桶身耐碰撞，防腐蚀，随时观察污水情况
- 随机附件一应俱全

Features

- The stainless or plastic tank is strong and durable.
- With a powerful lower-noise motor the vacuum cleaner has a special strong suction.
- LC-602J has tilted water decove,it is suitable to pour water.
- LC-602S has a new-style large wheel plate. It is stable and beautiful.
- LC-603J made of semitransparent plastic,the tank is bump-proof and erosion-proof and the waste water in the tank can be viewed anytime.
- A complete set of accessories are supplied with the vacuum cleaner.

亮洁牌80升吸尘吸水机

LIGHT CLEAN 80L Wet and Dry Vacuum Cleaner

千秋架
Tilt

LC-802J
配 1000W 马达
With 1000W Motor

LC-802JP
配 1500W 马达
With 1500W Motor



豪华底座
Luxury base

LC-802S
配 1000W 马达
With 1000W Motor

LC-802SP
配 1500W 马达
With 1500W Motor



产品特点

- 圆桶型不锈钢桶身，坚固耐用
- 配备强劲静音型马达，吸力特强
- LC-802J 配备千秋架式倒水，使用便捷
- LC-802S 配备新型大轮盘座，稳重美观
- 随机附件一应俱全

Features

- The stainless tank is strong and durable.
- With a powerful lower-noise motor the vacuum cleaner has a special strong suction.
- LC-802J has tilted water decove, it is suitable to pour water.
- LC-802S has a new-style large wheel plate. It is stable and beautiful.
- A complete set of accessories are supplied with the vacuum cleaner.

三马达款
Three-motor



LC-802J-3



LC-802S-3

技术参数 Technical Data

	LC-802J/LC-802JP/LC-802J-3	LC-802S/LC-802SP/LC-802S-3
功能 Function:	吸尘吸水 wet and dry	吸尘吸水 wet and dry
容量 Capacity:	80L	80L
功率 Power:	2000W/3000W/3000W	2000W/3000W/3000W
电压 Voltage:	220V-240V	220V-240V
高度 Height:	107cm	109cm
桶身直径 Tank diameter:	Φ440mm	Φ440mm
冷却模式 Mode of cooling:	循环风冷 Circulating air cooling	循环风冷 Circulating air cooling
气流量 Air flow rate:	106L/S 159L/S 159L/S	106L/S 159L/S 159L/S
真空吸力 Vacuum suction:	250mbar	250mbar
电源线长 Length of the cable:	8m	8m
配件直径 Hose diameter:	Φ40mm	Φ40mm
包装规格 Packing:	630×560×1160mm	640×625×1180mm
净重 Net weight:	27.5kg/27.5kg/29.2kg	33kg/33kg/34.7kg
毛重 Gross weight:	29.2kg/29.2kg/31.8kg	37kg/37kg/38.7kg

亮洁牌90升吸尘吸水机

LIGHT CLEAN 90L Wet and Dry Vacuum Cleaner

塑料桶
Plastic tank

LC-604

配 1000W 马达

With 1000W Motor

LC-604P

配 1500W 马达

With 1500W Motor



前带扒
Pre-water sucker

LC-604W

配 1000W 马达

With 1000W Motor

LC-604WP

配 1500W 马达

With 1500W Motor



三马达款
Three-motor



LC-604-3



LC-604-3W



吸水扒

Water sucker

产品特点

- 塑料桶身，坚固耐用
- 配备强劲静音型马达，吸力极强
- 半透明桶身耐碰撞，防腐蚀，随时观察污水情况
- 随机附件一应俱全

Features

- The plastic tank is strong and durable
- With a powerful lower-noise motor the vacuum cleaner has a special strong suction.
- Made of semitransparent plastic, the tank is bump-proof and erosion-proof and waste water in the tank can be viewed anytime.
- A complete set of accessories are supplied with the vacuum cleaner.

技术参数 Technical Data

	LC-604/LC-604P/LC-604-3	LC-604W/LC-604WP/LC-604-3W
功能 Function:	吸尘吸水 wet and dry	吸尘吸水 wet and dry
容量 Capacity:	90L	90L
功率 Power:	2000W/3000W/3000W	2000W/3000W/3000W
电压 Voltage:	220V-240V	220V-240V
高度 Height:	109cm	109cm
桶身直径 Tank diameter:	Φ440mm	Φ440mm
冷却模式 Mode of cooling:	循环风冷 Circulating air cooling	循环风冷 Circulating air cooling
气流量 Air flow rate:	106L/S 159L/S 159L/S	106L/S 159L/S 159L/S
真空吸力 Vacuum suction:	250mbar	250mbar
电源线长 Length of the cable:	8m	8m
配件直径 Hose diameter:	Φ40mm	Φ40mm
包装规格 Packing:	590×510×1020mm	740×510×1020mm
净重 Net weight:	27.2kg/27.2kg/28.6kg	31kg/31kg/32.7kg
毛重 Gross weight:	28.5kg/28.5kg/31.9kg	35kg/35kg/36.7kg

亮洁牌后带扒式吸尘吸水机

LIGHT CLEAN Wet and Dry Vacuum Cleaner With Squeegee

LC60-2W

配 1000W 马达
With 1000W Motor

LC60-2WP

配 1500W 马达
With 1500W Motor



60 升
60L

LC603W

配 1000W 马达
With 1000W Motor

LC603WP

配 1500W 马达
With 1500W Motor



塑料桶
Plastic tank

LC80-2W

配 1000W 马达
With 1000W Motor

LC80-2WP

配 1500W 马达
With 1500W Motor



80 升
80L



吸水扒
Water sucker

三马达款
Three-motor



LC60-3W



LC603W-3



LC80-3W

产品特点

- 圆桶型不锈钢桶身，坚固耐用
- 配备强劲静音型马达，吸力特强
- 后置式吸水扒，更快更干净
- 随机附件一应俱全

Features

- The stainless or plastic tank is strong and durable.
- With a powerful lower-noise motor, the vacuum cleaner has a special strong suction.
- Has postpositive water sucker, faster and cleaner.
- A complete set of accessories are supplied with the vacuum cleaner.

技术参数 Technical Data

	LC60-2W/LC60-2WP /LC60-3W	LC603W/LC603WP /LC603W-3	LC80-2W/LC80-2WP /LC80-3W
功能 Function:	吸尘吸水 wet and dry	吸尘吸水 wet and dry	吸尘吸水 wet and dry
容量 Capacity:	60L	60L	80L
功率 Power:	2000W/3000W/3000W	2000W/3000W/3000W	2000W/3000W/3000W
电压 Voltage:	220V-240V	220V-240V	220V-240V
高度 Height:	97cm	97cm	107cm
桶身直径 Tank diameter:	Φ440mm	Φ440mm	Φ440mm
冷却模式 Mode of cooling:	循环风冷 Circulating air cooling	循环风冷 Circulating air cooling	循环风冷 Circulating air cooling
气流量 Air flow rate:	106L/S 159L/S 159L/S	106L/S 159L/S 159L/S	106L/S 159L/S 159L/S
真空吸力 Vacuum suction:	250mbar	250mbar	250mbar
电源线长 Length of the cable:	8m	8m	8m
配件直径 Hose diameter:	Φ40mm	Φ40mm	Φ40mm
包装规格 Packing:	680×600×1060mm	680×600×1060mm	680×600×1180mm
净重 Net weight:	33.8kg/33.8kg/35.5kg	32.3kg/32.3kg/34.2kg	34.5kg/34.5kg/36.2kg
毛重 Gross weight:	38kg/38kg/39.7kg	36.5kg/36.5kg/38.2kg	39kg/39kg/40.7kg

亮洁牌后带尘扒式吸尘器

LIGHT CLEAN Vacuum Cleaner With Squeegee

LC60-2W

(单吸尘)

60 升
60L



LC603W

(单吸尘)

塑料桶
Plastic tank



LC80-2W

(单吸尘)

80 升
80L



三马达款
Three-motor



LC60-3W(单吸尘)



LC603W-3(单吸尘)



LC80-3W(单吸尘)

技术参数 Technical Data

	LC60-2W(单吸尘)	LC603W(单吸尘)	LC80-2W(单吸尘)
功能 Function:	吸尘吸水 wet and dry	吸尘吸水 wet and dry	吸尘吸水 wet and dry
容量 Capacity:	60L	60L	80L
功率 Power:	2000W/3000W	2000W/3000W	2000W/3000W
电压 Voltage:	220V-240V	220V-240V	220V-240V
高度 Height:	97cm	97cm	107cm
桶身直径 Tank diameter:	Φ440mm	Φ440mm	Φ440mm
冷却模式 Mode of cooling:	循环风冷 Circulating air cooling	循环风冷 Circulating air cooling	循环风冷 Circulating air cooling
气流量 Air flow rate:	106L/S	106L/S	106L/S
真空吸力 Vacuum suction:	250mbar	250mbar	250mbar
电源线长 Length of the cable:	8m	8m	8m
配件直径 Hose diameter:	Φ40mm	Φ40mm	Φ40mm
包装规格 Packing:	680×600×1060mm	680×600×1060mm	680×600×1180mm
净重 Net weight:	33.8kg	32.3kg	34.5kg
毛重 Gross weight:	38kg	36.5kg	39kg

产品特点

- 圆桶型不锈钢 / 塑料桶身，坚固耐用
- 配备强劲静音型马达，吸力特强
- 后置式吸尘扒，更快更干净
- 随机附件一应俱全

Features

- The stainless or plastic tank is strong and durable.
- With a powerful lower-noise motor, the vacuum cleaner has a special strong suction.
- Has postpositive sucker, faster and cleaner.
- A complete set of accessories are supplied with the vacuum cleaner.

海亮牌15升吸尘吸水机

HAI LIGHT 15L Wet and Dry Vacuum Cleaner

连体塑料桶
One-body plastic tank

HL151
配 1000W 马达
With 1000W Motor

HL151P
配 1500W 马达
With 1500W Motor



HL15
配 1000W 马达
With 1000W Motor

HL15P
配 1500W 马达
With 1500W Motor

普通底座
Normal base



塑料桶
Plastic tank

HL15B
配 1000W 马达
With 1000W Motor

HL15BP
配 1500W 马达
With 1500W Motor



技术参数 Technical Data

	HL151/HL151P	HL15B/HL15BP	HL15/HL15P
功能 Function:	吸尘吸水 wet and dry	吸尘吸水 wet and dry	吸尘吸水 wet and dry
容量 Capacity:	15L	15L	15L
功率 Power:	1000W/1500W	1000W/1500W	1000W/1500W
电压 Voltage:	220V-240V	220V-240V	220V-240V
高度 Height:	55cm	55cm	55cm
桶身直径 Tank diameter:	Φ345mm	Φ345mm	Φ345mm
冷却模式 Mode of cooling:	循环风冷 Circulating air cooling	循环风冷 Circulating air cooling	循环风冷 Circulating air cooling
气流量 Air flow rate:	48L/S	48L/S	48L/S
真空吸力 Vacuum suction:	210mbar/220mbar	210mbar/220mbar	210mbar/220mbar
电源线长 Length of the cable:	7m	7m	7m
配件直径 Hose diameter:	Φ36mm	Φ36mm	Φ36mm
包装规格 Packing:	400×400×560mm	410×410×600mm	410×410×600mm
净重 Net weight:	10kg	10.5kg	11.5kg
毛重 Gross weight:	11.2kg	12.2kg	13.2kg
颜色 Colour:			

产品特点

- 塑料 / 不锈钢桶身，坚固耐用
- 配备强劲静音型马达，吸力特强
- 新型宽大底座，稳重美观
- 随机附件一应俱全

Features

- Plastic/Stainless tank or stainless tank is strong and durable.
- With a powerful lower-noise motor the vacuum cleaner has a special strong suction.
- New-style large wheel plate. It is stable and beautiful.
- A complete set of accessories are supplied with the vacuum cleaner.

海亮牌30升吸尘吸水机

HAI LIGHT 30L Wet and Dry Vacuum Cleaner

普通底座
Normal base

HL30

配 1000W 马达
With 1000W Motor

HL30P

配 1500W 马达
With 1500W Motor



圆桶型不锈钢塑料桶身，坚固耐用
The stainless or plastic tank is strong and durable.

可配 $\Phi 40$ 弯钢管或 $\Phi 36$ 直钢管
($\Phi 40$ Bent steel tube or $\Phi 36$ Straight steel tube)

连体塑料桶
One-body plastic tank

HL301

配 1000W 马达
With 1000W Motor

HL301P

配 1500W 马达
With 1500W Motor

塑料桶身，坚固耐用

The plastic tank is strong and durable.

可配 $\Phi 40$ 弯钢管或 $\Phi 36$ 直钢管
($\Phi 40$ Bent steel tube or $\Phi 36$ Straight steel tube)



产品特点

- 配备强劲静音型马达，吸力特强
- 新型大轮盘宽底座，稳重美观
- 随机附件一应俱全

Features

- With a powerful lower-noise motor, the vacuum cleaner has a special strong suction.
- New-style large wheel plate. It is stable and beautiful.
- A complete set of accessories are supplied with the vacuum cleaner.

技术参数 Technical Data

	HL30/HL30P	HL301/HL301P
功能 Function:	吸尘吸水 wet and dry	吸尘吸水 wet and dry
容量 Capacity:	30L	30L
功率 Power:	1000W/1500W	1000W/1500W
电压 Voltage:	220V-240V	220V-240V
高度 Height:	76cm	76cm
桶身直径 Tank diameter:	$\Phi 345$ mm	$\Phi 345$ mm
冷却模式 Mode of cooling:	循环风冷 Circulating air cooling	循环风冷 Circulating air cooling
气流量 Air flow rate:	53L/S	53L/S
真空吸力 Vacuum suction:	230mbar/240mbar	230mbar/240mbar
电源线长 Length of the cable:	7m	7m
配件直径 Hose diameter:	$\Phi 36$ mm/ $\Phi 40$ mm	$\Phi 36$ mm/ $\Phi 40$ mm
包装规格 Packing:	410×410×795mm	400×400×745mm
净重 Net weight:	11.8kg	12kg
毛重 Gross weight:	13.6kg	13.5kg
颜色 Colour:		

海亮牌60升吸尘吸水机

HAI LIGHT 60L Wet and Dry Vacuum Cleaner

普通底座
Normal base

千秋架
Tilt

塑料桶
Plastic tank

HL60-2

配 1000W 马达
With 1000W Motor

HL60-2P

配 1500W 马达
With 1500W Motor



HL60-2J

配 1000W 马达
With 1000W Motor

HL60-2JP

配 1500W 马达
With 1500W Motor



HL60-2B

配 1000W 马达
With 1000W Motor

HL60-2BP

配 1500W 马达
With 1500W Motor



三马达款
Three-motor



HL60-3



HL60-3J



HL60-3B

技术参数 Technical Data

	HL60-2/HL60-2P /HL60-3	HL60-2J/HL60-2JP /HL60-3J	HL60-2B/HL60-2BP /HL60-3B
功能 Function:	吸尘吸水 wet and dry	吸尘吸水 wet and dry	吸尘吸水 wet and dry
容量 Capacity:	60L	60L	60L
功率 Power:	2000W/3000W/3000W	2000W/3000W/3000W	2000W/3000W/3000W
电压 Voltage:	220V-240V	220V-240V	220V-240V
高度 Height:	97cm	90cm	90cm
桶身直径 Tank diameter:	Φ440mm	Φ440mm	Φ440mm
冷却模式 Mode of cooling:	循环风冷 Circulating air cooling	循环风冷 Circulating air cooling	循环风冷 Circulating air cooling
气流量 Air flow rate:	106L/S 159L/S 159L/S	106L/S 159L/S 159L/S	106L/S 159L/S 159L/S
真空吸力 Vacuum suction:	250mbar	250mbar	250mbar
电源线长 Length of the cable:	8m	8m	8m
配件直径 Hose diameter:	Φ40mm	Φ40mm	Φ40mm
包装规格 Packing:	590×520×960mm	630×560×1040mm	590×520×960mm
净重 Net weight:	24.5kg/24.5kg/26.5kg	25.5kg/25.5kg/27.1kg	24kg/24kg/25.5kg
毛重 Gross weight:	27.5kg/27.5kg/29kg	26.5kg/26.5kg/28.3kg	27kg/27kg/28.5kg
颜色 Colour:			

产品特点

- 圆桶型不锈钢 / 塑料桶身，坚固耐用
- 配备强劲静音型马达，吸力特强
- HL60-2 配备新型大轮盘座，稳重美观
- HL60-2J 配备千秋架式倒水，使用便捷
- HL60-2B 桶身耐碰撞，防腐蚀，随时观
- 察污水情况
- 随机附件一应俱全

Features

- The stainless or plastic tank is strong and durable.
- With a powerful lower-noise motor the vacuum cleaner has a special strong suction.
- HL60-2 has a new-style large wheel plate. It is stable and beautiful.
- HL60-2J has tilting device, it is suitable to pour water.
- HL60-2B made of semitransparent plastic, the tank is bump-proof and erosion-proof and the waste water in the tank can be viewed anytime.
- A complete set of accessories are supplied with the vacuum cleaner.

海亮牌80升吸尘吸水机

HAI LIGHT 80L Wet and Dry Vacuum Cleaner

普通底座
Normal base

HL80-2

配 1000W 马达

With 1000W Motor

HL80-2P

配 1500W 马达

With 1500W Motor



千秋架
Tilt

HL80-2J

配 1000W 马达

With 1000W Motor

HL80-2JP

配 1500W 马达

With 1500W Motor



三马达款
Three-motor



HL80-3



HL80-3J

产品特点

- 圆桶型不锈钢桶身，坚固耐用
- 配备强劲静音型马达，吸力特强
- HL80-2 配备新型大轮盘座，稳重美观
- HL80-2J 配备千秋架式倒水，使用便捷
- 随机附件一应俱全

Features

- The stainless or plastic tank is strong and durable.
- With a powerful lower-noise motor the vacuum cleaner has a special strong suction.
- HL80-2 has a new-style large wheel plate. It is stable and beautiful.
- HL80-2J has tilted water decove, it is suitable to pour water.
- A complete set of accessories are supplied with the vacuum cleaner.

技术参数 Technical Data

	HL80-2/HL80-2P/HL80-3	HL80-2J/HL80-2JP/HL80-3J
功能 Function:	吸尘吸水 wet and dry	吸尘吸水 wet and dry
容量 Capacity:	80L	80L
功率 Power:	2000W/3000W/3000W	2000W/3000W/3000W
电压 Voltage:	220V-240V	220V-240V
高度 Height:	100cm	100cm
桶身直径 Tank diameter:	Φ440mm	Φ440mm
冷却模式 Mode of cooling:	循环风冷 Circulating air cooling	循环风冷 Circulating air cooling
气流量 Air flow rate:	106L/S 159L/S 159L/S	106L/S 159L/S 159L/S
真空吸力 Vacuum suction:	250mbar	250mbar
电源线长 Length of the cable:	8m	8m
配件直径 Hose diameter:	Φ40mm	Φ40mm
包装规格 Packing:	590×520×1055mm	630×560×1140mm
净重 Net weight:	25kg/25kg/26.5kg	26.8kg/26.8kg/28.3kg
毛重 Gross weight:	28.7kg/28.7kg/30.2kg	30.5kg/30.5kg/32kg
颜色 Colour:		

海亮牌90升吸尘吸水机

HAI LIGHT 90L Wet and Dry Vacuum Cleaner

塑料桶
Plastic tank

HL90-2
配 1000W 马达
With 1000W Motor

HL90-2P
配 1500W 马达
With 1500W Motor



前带扒
Pre-water sucker

HL90-2W
配 1000W 马达
With 1000W Motor

HL90-2WP
配 1500W 马达
With 1500W Motor



三马达款
Three-motor



HL90-3



HL90-3W



吸水扒
Water sucker

产品特点

- 塑料桶身，坚固耐用
- 配备强劲静音型马达，吸力特强
- 半透明桶身耐碰撞，防腐蚀，随时观察污水情况
- 随机附件一应俱全

Features

- The plastic tank is strong and durable.
- With a powerful lower-noise motor the vacuum cleaner has a special strong suction.
- Made of semitransparent plastic, the tank is bump-proof and erosion-proof and the waste water in the tank can be viewed anytime.
- A complete set of accessories are supplied with the vacuum cleaner.

技术参数 Technical Data

	HL90-2/HL90-2P/HL90-3	HL90-2W/HL90-2WP/HL90-3W
功能 Function:	吸尘吸水 wet and dry	吸尘吸水 wet and dry
容量 Capacity:	90L	90L
功率 Power:	2000W/3000W/3000W	2000W/3000W/3000W
电压 Voltage:	220V-240V	220V-240V
高度 Height:	100cm	100cm
桶身直径 Tank diameter:	Φ440mm	Φ440mm
冷却模式 Mode of cooling:	循环风冷 Circulating air cooling	循环风冷 Circulating air cooling
气流量 Air flow rate:	106L/S 159L/S 159L/S	106L/S 159L/S 159L/S
真空吸力 Vacuum suction:	250mbar	250mbar
电源线长 Length of the cable:	8m	8m
配件直径 Hose diameter:	Φ40mm	Φ40mm
包装规格 Packing:	590×510×995mm	740×510×995mm
净重 Net weight:	27kg/27kg/28.5kg	32kg/32kg/33.5kg
毛重 Gross weight:	30kg/30kg/31.5kg	35kg/35kg/36.5kg
颜色 Colour:		

海亮牌后带扒式吸尘吸水机

HAI LIGHT Wet and Dry Vacuum Cleaner With Squeegee

60 升
60L

塑料桶
Plastic tank

80 升
80L

HL60-2W

配 1000W 马达
With 1000W Motor

HL60-2WP

配 1500W 马达
With 1500W Motor



HL60-2BW

配 1000W 马达
With 1000W Motor

HL60-2BWP

配 1500W 马达
With 1500W Motor



HL80-2W

配 1000W 马达
With 1000W Motor

HL80-2WP

配 1500W 马达
With 1500W Motor



吸水扒
Water sucker

三马达款
Three-motor



HL60-3W



HL60-3BW



HL80-3W

产品特点

- 圆桶型不锈钢 / 塑料桶身，坚固耐用
- 配备强劲静音型马达，吸力特强
- 千秋架式倒水，使用便捷
- 后置式吸水扒，更快更干净，效率更高
- 随机附件一应俱全

Features

- The stainless or plastic tank is strong and durable.
- With a powerful lower-noise motor the vacuum cleaner has a special strong suction.
- Has tilted water decove,it is suitable to pour water,
- Has postpositive water sucker,faster and cleaner,more efficient.
- A complete set of accessories are supplied with the vacuum cleaner.

技术参数 Technical Data

	HL60-2W/HL60-2WP/ HL60-3W	HL60-2BW/HL60-2BWP/ HL60-3BW	HL80-2W/HL80-2WP/ HL80-3W
功能 Function:	吸尘吸水 wet and dry	吸尘吸水 wet and dry	吸尘吸水 wet and dry
容量 Capacity:	60L	60L	80L
功率 Power:	2000W/3000W/3000W	2000W/3000W/3000W	2000W/3000W/3000W
电压 Voltage:	220V-240V	220V-240V	220V-240V
高度 Height:	90cm	90cm	100cm
桶身直径 Tank diameter:	Φ440mm	Φ440mm	Φ440mm
冷却模式 Mode of cooling:	循环风冷 Circulating air cooling	循环风冷 Circulating air cooling	循环风冷 Circulating air cooling
气流量 Air flow rate:	106L/S 159L/S 159L/S	106L/S 159L/S 159L/S	106L/S 159L/S 159L/S
真空吸力 Vacuum suction:	250mbar	250mbar	250mbar
电源线长 Length of the cable:	8m	8m	8m
配件直径 Hose diameter:	Φ40mm	Φ40mm	Φ40mm
包装规格 Packing:	680×600×1040mm	680×600×1040mm	680×600×1140mm
净重 Net weight:	33.5kg/33.5kg/35kg	32.5kg/32.5kg/34kg	32.5kg/32.5kg/34kg
毛重 Gross weight:	37.5kg/37.5kg/39kg	36.5kg/36.5kg/38kg	39kg/39kg/40.5kg
颜色 Colour:			

海亮牌后带尘扒式吸尘器

HAI LIGHT Vacuum Cleaner With Squeegee



60 升
60L



塑料桶
Plastic tank



80 升
80L



三马达款
Three-motor



HL60-3W(单吸尘) HL60-3BW(单吸尘) HL80-3W(单吸尘)

技术参数 Technical Data

	HL60-2W(单吸尘)	HL60-2BW(单吸尘)	HL80-2W(单吸尘)
功能 Function:	吸尘吸水 wet and dry	吸尘吸水 wet and dry	吸尘吸水 wet and dry
容量 Capacity:	60L	60L	80L
功率 Power:	2000W	2000W	2000W
电压 Voltage:	220V-240V	220V-240V	220V-240V
高度 Height:	90cm	90cm	100cm
桶身直径 Tank diameter:	Φ440mm	Φ440mm	Φ440mm
冷却模式 Mode of cooling:	循环风冷 Circulating air cooling	循环风冷 Circulating air cooling	循环风冷 Circulating air cooling
气流量 Air flow rate:	106L/S	106L/S	106L/S
真空吸力 Vacuum suction:	250mbar	250mbar	250mbar
电源线长 Length of the cable:	8m	8m	8m
配件直径 Hose diameter:	Φ40mm	Φ40mm	Φ40mm
包装规格 Packing:	680×600×1040mm	680×600×1040mm	680×600×1140mm
净重 Net weight:	33.5kg	32.5kg	34.5kg
毛重 Gross weight:	37.5kg	36.5kg	39kg
颜色 Colour:			

产品特点

- 圆桶型不锈钢 / 塑料桶身，坚固耐用
- 配备强劲静音型马达，吸力特强
- 后置式吸尘扒，更快更干净
- 随机附件一应俱全

Features

- The stainless or plastic tank is strong and durable.
- With a powerful lower-noise motor the vacuum cleaner has a special strong suction.
- Has postpositive sucker, faster and cleaned, more efficient.
- A complete set of accessories are supplied with the vacuum cleaner.

KIMBO 10升真空吸尘机

KIMBO 10L Vacuum



内置尘隔
Built-in dust bag

AS-102C

产品特点

- 外观设计超前时尚，吸力强劲的进口吸尘电机使它得以长时间不间断操作，完美的隔音设计，最能适应对噪音敏感区域的清洁。

Features

- It has a fashionable appearance. The imported vacuum motor, which has a strong suction, allows a long and uninterrupted operation. The perfect sound insulation design makes it suitable for noise sensitive site. It contains a large capacity wool dust-collecting bag, preventing fine dust from getting out, while keeping a strong suction. The product is compact, light and handy, not taking a large place for storing. It is the best choice cleaner for hotels, rooms office and families.

技术参数 Technical Data

	AS-102C
功能 Function:	吸尘 dry
容量 Capacity:	10L
功率 Power:	1000W
电压 Voltage:	220V-240V
高度 Height:	32cm
桶身直径 Tank diameter:	Φ345mm
冷却模式 Mode of cooling:	循环风冷 Circulating air cooling
气流量 Air flow rate:	48L/S
真空吸力 Vacuum suction:	210mbar
电源线长 Length of the cable:	7m
配件直径 Hose diameter:	Φ36mm
包装规格 Packing:	390×345×530mm
净重 Net weight:	7.2kg
毛重 Gross weight:	8.3kg

KIMBO 15升吸尘吸水机

KIMBO 15L Wet and Dry Vacuum Cleaner

塑料桶
Plastic tank

AS15B

配 1000W 马达
With 1000W Motor

AS15BP

配 1500W 马达
With 1500W Motor



连体塑料桶
One-body plastic tank

AS151

配 1000W 马达
With 1000W Motor

AS151P

配 1500W 马达
With 1500W Motor



普通底座
Normal base

AS15

配 1000W 马达
With 1000W Motor

AS15P

配 1500W 马达
With 1500W Motor



技术参数 Technical Data

	AS151/AS151P	AS15B/AS15BP	AS15/AS15P
功能 Function:	吸尘吸水 wet and dry	吸尘吸水 wet and dry	吸尘吸水 wet and dry
容量 Capacity:	15L	15L	15L
功率 Power:	1000W/1500W	1000W/1500W	1000W/1500W
电压 Voltage:	220V-240V	220V-240V	220V-240V
高度 Height:	55cm	55cm	55cm
桶身直径 Tank diameter:	Φ345mm	Φ345mm	Φ345mm
冷却模式 Mode of cooling:	循环风冷 Circulating air cooling	循环风冷 Circulating air cooling	循环风冷 Circulating air cooling
气流量 Air flow rate:	48L/S	48L/S	48L/S
真空吸力 Vacuum suction:	210mbar/220mbar	210mbar/220mbar	210mbar/220mbar
电源线长 Length of the cable:	7m	7m	7m
配件直径 Hose diameter:	Φ36mm/Φ40mm	Φ36mm	Φ36mm
包装规格 Packing:	400×400×560mm	410×410×600mm	410×410×610mm
净重 Net weight:	10.3kg	10.3kg	11.8kg
毛重 Gross weight:	12.2kg	12.2kg	13.2kg
颜色 Colour:			

产品特点

- 塑料 / 不锈钢桶身，坚固耐用
- 配备强劲静音型马达，吸力特强
- 新型宽大底座，稳重美观
- 随机附件一应俱全

Features

- The plastic or stainless tank is strong and durable.
- With a powerful lower-noise motor the vacuum cleaner has a special strong suction.
- New-style large wheel plate. It is stable and beautiful.
- A complete set of accessories are supplied with the vacuum cleaner.

KIMBO 30升吸尘吸水机

KIMBO 30L Wet and Dry Vacuum Cleaner

连体塑料桶
One-body plastic tank

普通底座
Normal base

AS301

配 1000W 马达
With 1000W Motor

AS301P

配 1500W 马达
With 1500W Motor

AS30

配 1000W 马达
With 1000W Motor

AS30P

配 1500W 马达
With 1500W Motor



产品特点

- 圆桶型不锈钢 / 塑料桶身，坚固耐用
- 配备强劲静音型马达，吸力特强
- 新型大轮盘座 / 新型宽大底座，稳重美观
- 随机附件一应俱全

Features

- The stainless tank is strong and durable.
- With a powerful lower-noise motor, the vacuum cleaner has a special strong suction.
- New-style large wheel plate. It is stable and beautiful.
- A complete set of accessories are supplied with the vacuum cleaner.

技术参数 Technical Data

	AS30/AS30P	AS301/AS301P
功能 Function:	吸尘吸水 wet and dry	吸尘吸水 wet and dry
容量 Capacity:	30L	30L
功率 Power:	1000W/1500W	1000W/1500W
电压 Voltage:	220V-240V	220V-240V
高度 Height:	76cm	76cm
桶身直径 Tank diameter:	$\phi 345$ mm	$\phi 345$ mm
冷却模式 Mode of cooling:	循环风冷 Circulating air cooling	循环风冷 Circulating air cooling
气流量 Air flow rate:	53L/S	53L/S
真空吸力 Vacuum suction:	230mbar/240mbar	230mbar/240mbar
电源线长 Length of the cable:	7m	7m
配件直径 Hose diameter:	$\phi 36$ mm/ $\phi 40$ mm	$\phi 36$ mm/ $\phi 40$ mm
包装规格 Packing:	410×410×795mm	400×400×745mm
净重 Net weight:	12.8kg	12kg
毛重 Gross weight:	15kg	12.85kg
颜色 Colour:		

KIMBO 60升吸尘吸水机

KIMBO 60L Wet and Dry Vacuum Cleaner

普通底座
Normal base

AS60-2
配 1000W 马达
With 1000W Motor

AS60-2P
配 1500W 马达
With 1500W Motor



千秋架
Tilt

AS60-2J
配 1000W 马达
With 1000W Motor

AS60-2JP
配 1500W 马达
With 1500W Motor



塑料桶
Plastic tank

AS60-2B
配 1000W 马达
With 1000W Motor

AS60-2BP
配 1500W 马达
With 1500W Motor



三马达款
Three-motor



AS60-3



AS60-3J



AS60-3B

技术参数 Technical Data

	AS60-2/AS60-2P/AS60-3	AS60-2J/AS60-2JP/AS60-3J	AS60-2B/AS60-2BP/AS60-3B
功能 Function:	吸尘吸水 wet and dry	吸尘吸水 wet and dry	吸尘吸水 wet and dry
容量 Capacity:	60L	60L	60L
功率 Power:	2000W/3000W/3000W	2000W/3000W/3000W	2000W/3000W/3000W
电压 Voltage:	220V-240V	220V-240V	220V-240V
高度 Height:	90cm	90cm	90cm
桶身直径 Tank diameter:	Φ440mm	Φ440mm	Φ440mm
冷却模式 Mode of cooling:	循环风冷 Circulating air cooling	循环风冷 Circulating air cooling	循环风冷 Circulating air cooling
气流量 Air flow rate:	106L/S 159L/S 159L/S	106L/S 159L/S 159L/S	106L/S 159L/S 159L/S
真空吸力 Vacuum suction:	250mbar	250mbar	250mbar
电源线长 Length of the cable:	8m	8m	8m
配件直径 Hose diameter:	Φ40mm	Φ40mm	Φ40mm
包装规格 Packing:	590×520×970mm	630×560×1040mm	590×520×960mm
净重 Net weight:	24.5kg/24.5kg/26.5kg	24.2kg/24.2kg/23.2kg	24kg/24kg/25.7kg
毛重 Gross weight:	26.38kg/26kg/28kg	26.5kg/26.5kg/25.5kg	25kg/26.5kg/28.5kg
颜色 Colour:			

产品特点

- 圆桶型不锈钢 / 塑料桶身，坚固耐用
- 配备强劲静音型马达，吸力特强
- AS60-2 配备新型大轮盘座，稳重美观
- AS60-2J 配备千秋架式倒水，使用便捷
- AS60-2B 桶身耐碰撞，防腐蚀，随时观察污水情况
- 随机配备附件一应俱全

Features

- The stainless or plastic tank is strong and durable.
- With a powerful lower-noise motor the vacuum cleaner has a special strong suction.
- AS60-2 has a new-style large wheel plate. It is stable and beautiful.
- AS60-2J has tilted water decove, it is suitable to pour water.
- AS60-2B made of semitransparent plastic, the tank is bump-proof and erosion-proof and the waste water in the tank can be viewed anytime
- A complete set of accessories are supplied with the vacuum cleaner.

KIMBO 80升吸尘吸水机

KIMBO 80L Wet and Dry Vacuum Cleaner

千秋架
Tilt

AS80-2J

配 1000W 马达

With 1000W Motor

AS80-2JP

配 1500W 马达

With 1500W Motor



普通底座
Normal base

AS80-2

配 1000W 马达

With 1000W Motor

AS80-2P

配 1500W 马达

With 1500W Motor



三马达款
Three-motor



AS80-3

AS80-3J

产品特点

- 圆桶型不锈钢桶身，坚固耐用
- 配备强劲静音型马达，吸力特强
- AS80-2 配备新型大型大轮盘座，稳重美观
- AS80-2J 配备千秋架式倒水，使用便捷
- 随机附件一应俱全

Features

- The stainless tank is strong and durable.
- With a powerful lower-noise motor the vacuum cleaner has a special strong suction.
- AS80-2 Has a new-atyle large wheel plate.It is stable and beautiful.
- AS80-2J Has tilted water decove,it is suitable to pour water.
- A complete set of accessories are supplied with the vacuum cleaner.

技术参数 Technical Data

	AS80-2/AS80-2P/AS80-3	AS80-2J/AS80-2JP/AS80-3J
功能 Function:	吸尘吸水 wet and dry	吸尘吸水 wet and dry
容量 Capacity:	80L	80L
功率 Power:	2000W/3000W/3000W	2000W/3000W/3000W
电压 Voltage:	220V-240V	220V-240V
高度 Height:	100cm	100cm
桶身直径 Tank diameter:	Φ440mm	Φ440mm
冷却模式 Mode of cooling:	循环风冷 Circulating air cooling	循环风冷 Circulating air cooling
气流量 Air flow rate:	106L/S 159L/S 159L/S	106L/S 159L/S 159L/S
真空吸力 Vacuum suction:	250mbar	250mbar
电源线长 Length of the cable:	8m	8m
配件直径 Hose diameter:	Φ40mm	Φ40mm
包装规格 Packing:	590×520×1055mm	630×560×1140mm
净重 Net weight:	25.7kg/25.7kg/27kg	27kg/27kg/29kg
毛重 Gross weight:	28.7kg/28.7kg/30.7kg	28.1kg/28.1kg/30kg
颜色 Colour:		

KIMBO 90升吸尘吸水机

KIMBO 90L Wet and Dry Vacuum Cleaner

塑料桶
Plastic tank

AS90-2

配 1000W 马达
With 1000W Motor

AS90-2P

配 1500W 马达
With 1500W Motor



前带扒
Rre-water sucker

AS90-2W

配 1000W 马达
With 1000W Motor

AS90-2WP

配 1500W 马达
With 1500W Motor



三马达款
Three-motor



AS90-3



AS90-3W



吸水扒
Water sucker

产品特点

- 塑料桶身，坚固耐用
- 配备强劲静音型马达，吸力特强
- 半透明桶身耐碰撞，防腐蚀，随时观察污水情况
- 随机附件一应俱全

Features

- The plastic tank is strong and durable
- With a powerful lower-noise motor the vacuum cleaner has a special strong suction
- Made of semitransparent plastic, the tank is bump-proof and erosion-proof and the waste water in the tank can be viewed anytime
- A complete set of accessories are supplied with the vacuum cleaner

技术参数 Technical Data

	AS90-2/AS90-2P/AS90-3	AS90-2W/AS90-2WP/AS90-3W
功能 Function:	吸尘吸水 wet and dry	吸尘吸水 wet and dry
容量 Capacity:	90L	90L
功率 Power:	2000W/3000W/3000W	2000W/3000W/3000W
电压 Voltage:	220V-240V	220V-240V
高度 Height:	90cm	90cm
桶身直径 Tank diameter:	Φ450mm	Φ450mm
冷却模式 Mode of cooling:	循环风冷 Circulating air cooling	循环风冷 Circulating air cooling
气流量 Air flow rate:	106L/S 159L/S 159L/S	106L/S 159L/S 159L/S
真空吸力 Vacuum suction:	250mbar	250mbar
电源线长 Length of the cable:	8m	8m
配件直径 Hose diameter:	Φ40mm	Φ40mm
包装规格 Packing:	590×510×955mm	740×510×995mm
净重 Net weight:	27.5kg/27.5kg/29.2kg	33.5kg/33.5kg/35kg
毛重 Gross weight:	30.5kg/30.5kg/32.2kg	36.5kg/36.5kg/38kg
颜色 Colour:		

KIMBO 后带扒式吸尘吸水机

KIMBO Wet and Dry Vacuum Cleaner With Squeegee

60 升
60L

AS60-2W

配 1000W 马达
With 1000W Motor

AS60-2WP

配 1500W 马达
With 1500W Motor



80 升
80L

AS80-2W

配 1000W 马达
With 1000W Motor

AS80-2WP

配 1500W 马达
With 1500W Motor



塑料桶
Plastic tank

AS60-2BW

配 1000W 马达
With 1000W Motor

AS60-2BWP

配 1500W 马达
With 1500W Motor



三马达款
Three-motor



AS60-3W



AS60-3BW



AS80-3W

防止泥浆进入马达
Prevent the mud from entering the motor



浮球密封胶套



密封浮球架

浮球密封胶套更密封,不会在水满浮球浮起时产生吸力,杜绝污水吸进机头部位。浮球架360度全密封,机头角度可以任意调转,也不会有污水吸进机头部分。

The floating ball sealant sleeve is more sealed, which will not produce suction when the floating ball is full of water, and prevent sewage from being sucked into the machine head.

The floating ball stand is fully sealed in 360 degrees, and the angle of the head can be adjusted at will, and no sewage will be sucked into the head part.

产品特点

- 圆桶型不锈钢桶身,坚固耐用
- 配备强劲静音型马达,吸力特强
- 千秋架式倒水,使用便捷
- 后置式吸水扒,更快更干净
- 随机附件一应俱全

Features

- The stainless tank is strong and durable.
- With a powerful lower-noise motor the vacuum cleaner has a special strong suction.
- Has tilted water decove,it is suitable to pour water.
- Has postpositive water sucker,faster and cleaner.
- A complete set of accessories are supplied with the vacuum cleaner.

技术参数 Technical Data

	AS60-2W/AS60-2WP /AS60-3W	AS60-2BW/ AS60-2BWP/ AS60-3BW	AS80-2W/AS80-2WP /AS80-3W
功能 Function:	吸尘吸水 wet and dry	吸尘吸水 wet and dry	吸尘吸水 wet and dry
容量 Capacity:	60L	60L	80L
功率 Power:	2000W/3000W/3000W	2000W/3000W/3000W	2000W/3000W/3000W
电压 Voltage:	220V-240V	220V-240V	220V-240V
高度 Height:	90cm	90cm	100cm
桶身直径 Tank diameter:	Φ440mm	Φ440mm	Φ440mm
冷却模式 Mode of cooling:	循环风冷 Circulating air cooling	循环风冷 Circulating air cooling	循环风冷 Circulating air cooling
气流量 Air flow rate:	106L/S 159L/S 159L/S	106L/S 159L/S 159L/S	106L/S 159L/S 159L/S
真空吸力 Vacuum suction:	250mbar	250mbar	250mbar
电源线长 Length of the cable:	8m	8m	8m
配件直径 Hose diameter:	Φ40mm	Φ40mm	Φ40mm
包装规格 Packing:	680×600×1060mm	680×600×1060mm	680×600×1080mm
净重 Net weight:	33.5kg/33.5kg/35.5kg	32.5kg/32.5kg/34kg	35.2kg/35.2kg/36.7kg
毛重 Gross weight:	37.5kg/37.5kg/39.5kg	36.5kg/36.5kg/38kg	37.8kg/37.8kg/39.7kg
颜色 Colour:			

深海洁牌10升超静音型吸尘机

SEA CLEAN 10L Super Lower-noise Dry Vacuum Cleaner

产品特点

- 外观设计超前时尚，吸力强劲的进口吸尘电机使它得以长时间不间断操作，完美的隔音设计，最能适应对噪音敏感区域的清洁。

Features

- It has a fashionable appearance. The imported vacuum motor, which has a strong suction, allows a long and uninterrupted operation. The perfect sound insulation design makes it suitable for noise sensitive site. It contains a large capacity wool dust-collecting bag, preventing fine dust from getting out, while keeping a strong suction. The product is compact, light and handy, not taking a large place for storing. It is the best choice cleaner for hotels, rooms office and families.



SC-101

技术参数 Technical Data

	SC-101		SC-101
功能 Function:	吸尘 dry	气流量 Air flow rate:	48L/S
容量 Capacity:	10L	真空吸力 Vacuum suction:	210mbar
功率 Power:	1000W	电源线长 Length of the cable:	7m
电压 Voltage:	220V-240V	配件直径 Hose diameter:	Φ36mm
高度 Height:	32cm	包装规格 Packing:	380×380×515mm
桶身直径 Tank diameter:	Φ345mm	净重 Net weight:	9.34kg
冷却模式 Mode of cooling:	循环冷风 Circulating air cooling	毛重 Gross weight:	10.54kg

深海洁牌15升吸尘吸水机

SEA CLEAN 15L Wet and Dry Vacuum Cleaner

技术参数 Technical Data

	SC-151/SC-151N
功能 Function:	吸尘吸水 wet and dry
容量 Capacity:	15L
功率 Power:	1000W
电压 Voltage:	220V-240V
高度 Height:	58cm
桶身直径 Tank diameter:	Φ345mm
冷却模式 Mode of cooling:	循环风冷 Circulating air cooling
气流量 Air flow rate:	48L/S
真空吸力 Vacuum suction:	210mbar
电源线长 Length of the cable:	7m
配件直径 Hose diameter:	Φ36mm
包装规格 Packing:	SC-151: 438×438×650mm SC-151N: 410×410×640mm
净重 Net weight:	11.9kg/10.9kg
毛重 Gross weight:	13.8kg/12.7kg



豪华底座
Luxury base

普通底座
Normal base

SC-151

SC-151N

产品特点

- 圆桶型不锈钢桶身，坚固耐用，配备强劲静音型马达，吸力特强，新型大轮盘座，稳重美观，随机附件一应俱全。

Features

- The stainless tank is strong and durable, with a powerful lower-noise motor, the vacuum cleaner has a special strong suction. New-style large wheel plate. It is stable and beautiful. A complete set of accessories are supplied with the vacuum cleaner.

深海洁牌30升吸尘吸水机

SEA CLEAN 30L Wet and Dry Vacuum Cleaner

SC-301N

普通底座
Normal base



SC-301

豪华底座
Luxury base



产品特点

- 圆桶型不锈钢 / 塑料桶身，坚固耐用
- 配备强劲静音型马达，吸力特强
- 新型大轮盘座 / 新型宽大底座，稳重美观
- 随机附件一应俱全

Features

- The stainless or plastic tank is strong and durable.
- With a powerful lower-noise motor the vacuum cleaner has a special strong suction.
- NEW-style large wheel plate It is stable and beautiful.
- A complete set of accessories are supplied with the vacuum cleaner.

连体塑料桶
One-body plastic tank

可配钢管或塑料管
(Steel pipe or Plastic pipe)



SC-301B

技术参数 Technical Data

	SC-301	SC-301N	SC-301B
功能 Function:	吸尘吸水 wet and dry	吸尘吸水 wet and dry	吸尘吸水 wet and dry
容量 Capacity:	30L	30L	30L
功率 Power:	1000W	1000W	1000W
电压 Voltage:	220V-240V	220V-240V	220V-240V
高度 Height:	78cm	78cm	76cm
桶身直径 Tank diameter:	Φ345mm	Φ345mm	Φ345mm
冷却模式 Mode of cooling:	循环风冷 Circulating air cooling	循环风冷 Circulating air cooling	循环风冷 Circulating air cooling
气流量 Air flow rate:	53L/S	53L/S	53L/S
真空吸力 Vacuum suction:	230mbar	230mbar	230mbar
电源线长 Length of the cable:	7m	7m	7m
配件直径 Hose diameter:	Φ40mm	Φ40mm	Φ36mm
包装规格 Packing:	438×438×825mm	410×410×815mm	400×400×780mm
净重 Net weight:	13.3kg	12.3kg	12kg
毛重 Gross weight:	15.4kg	14.3kg	13.5kg

深海洁牌60升吸尘吸水机

SEA CLEAN 60L Wet and Dry Vacuum Cleaner

千秋架
Tilt



SC-602J

豪华底座
Luxury base



SC-602S

塑料桶
Plastic tank



SC-603J

三马达款
Three-motor



SC-602J-3



SC-602S-3



SC-603J-3

技术参数 Technical Data

	SC-602S/SC-602S-3		SC-603J/SC-603J-3		SC-602J/SC-602J-3	
功能 Function:	吸尘吸水 wet and dry		吸尘吸水 wet and dry		吸尘吸水 wet and dry	
容量 Capacity:	60L		60L		60L	
功率 Power:	2000W	3000W	2000W	3000W	2000W	3000W
电压 Voltage:	220V-240V		220V-240V		220V-240V	
高度 Height:	94cm		87cm		97cm	
桶身直径 Tank diameter:	Φ440mm		Φ440mm		Φ440mm	
冷却模式 Mode of cooling:	循环风冷 Circulating air cooling		循环风冷 Circulating air cooling		循环风冷 Circulating air cooling	
气流量 Air flow rate:	106L/S	159L/S	106L/S	159L/S	106L/S	159L/S
真空吸力 Vacuum suction:	250mbar		250mbar		250mbar	
电源线长 Length of the cable:	8m		8m		8m	
配件直径 Hose diameter:	Φ40mm		Φ40mm		Φ40mm	
包装规格 Packing:	625×595×1040mm		590×520×995mm		630×560×1040mm	
净重 Net weight:	31kg/32.7kg		24kg/26kg		26kg/27.3kg	
毛重 Gross weight:	31.6kg/33.5kg		25kg/27kg		27kg/29kg	

产品特点

- 圆桶型不锈钢 / 塑料桶身，坚固耐用
- 配备强劲静音型马达，吸力特强
- SC-602J 配备千秋架式倒水，使用便捷
- SC-602S 配备新型大轮盘座，稳重美观
- SC-603J 桶身耐碰撞，防腐蚀，随时观察污水情况
- 随机附件一应俱全

Features

- The stainless or plastic tank is strong and durable.
- With a powerful lower-noise motor the vacuum cleaner has a special strong suction.
- SC-602J has tilted water decove, it is suitable to pour water.
- SC-602B has a new-style large wheel plate. It is stable and beautiful.
- SC-603J made of semitransparent plastic, the tank is bump-proof and erosion-proof and the waste water in the tank can be viewed anytime.
- A complete set of accessories are supplied with the vacuum cleaner.

深海洁牌80升吸尘吸水机

SEA CLEAN 80L Wet and Dry Vacuum Cleaner



产品特点

- 圆桶型不锈钢桶身，坚固耐用
- 配备强劲静音型马达，吸力特强
- SC-802J 配备千秋架式倒水，使用便捷
- SC-802S 配备新型大轮盘座，稳重美观
- 随机附件一应俱全

Features

- The stainless tank is strong and durable.
- With a powerful lower-noise motor the vacuum cleaner has a special strong suction.
- SC-802J has tilted water decove, it is suitable to pour water.
- SC-802S has a new-style large wheel plate. It is stable and beautiful.
- A complete set of accessories are supplied with the vacuum cleaner.

技术参数 Technical Data

	SC-802S/SC-802S-3	SC-802J/SC-802J-3
功能 Function:	吸尘吸水 wet and dry	吸尘吸水 wet and dry
容量 Capacity:	80L	80L
功率 Power:	2000W/3000W	2000W/3000W
电压 Voltage:	220V-240V	220V-240V
高度 Height:	109cm	107cm
桶身直径 Tank diameter:	Φ440mm	Φ440mm
冷却模式 Mode of cooling:	循环风冷 Circulating air cooling	循环风冷 Circulating air cooling
气流量 Air flow rate:	106L/S 159L/S	106L/S 159L/S
真空吸力 Vacuum suction:	250mbar	250mbar
电源线长 Length of the cable:	8m	8m
配件直径 Hose diameter:	Φ40mm	Φ40mm
包装规格 Packing:	640×625×1175mm	630×560×1140mm
净重 Net weight:	30.6kg/32.2kg	29kg/30.5kg
毛重 Gross weight:	34.6kg/36kg	32kg/33.5kg

深海洁牌90升吸尘吸水机

SEA CLEAN 90L Wet and Dry Vacuum Cleaner



塑料桶
Plastic tank

SC-604



前带扒
Pre-water sucker

SC-604W

三马达款
Three-motor



SC-604-3



SC-604-3W



吸水扒
Water sucker

产品特点

- 塑料桶身，坚固耐用
- 配备强劲静音型马达，吸力特强
- 半透明桶身耐碰撞，防腐蚀，随时观察污水情况
- 随机附件一应俱全

Features

- The plastic tank is strong and durable.
- With a powerful lower-noise motor the vacuum cleaner has a special strong suction.
- Made of semitransparent plastic, the tank is bump-proof and erosion-proof and the waste water in the tank can be viewed anytime.
- A complete set of accessories are supplied with the vacuum cleaner.

技术参数 Technical Data

	SC-604/SC-604-3	SC-604W/SC-604-3W
功能 Function:	吸尘吸水 wet and dry	吸尘吸水 wet and dry
容量 Capacity:	90L	90L
功率 Power:	2000W/3000W	2000W/3000W
电压 Voltage:	220V-240V	220V-240V
高度 Height:	92cm	109cm
桶身直径 Tank diameter:	Φ440mm	Φ440mm
冷却模式 Mode of cooling:	循环风冷 Circulating air cooling	循环风冷 Circulating air cooling
气流量 Air flow rate:	106L/S 159L/S	106L/S 159L/S
真空吸力 Vacuum suction:	250mbar	250mbar
电源线长 Length of the cable:	8m	8m
配件直径 Hose diameter:	Φ40mm	Φ40mm
包装规格 Packing:	590×510×995mm	740×510×995mm
净重 Net weight:	27kg/28.2kg	32kg/33.5kg
毛重 Gross weight:	30.3kg/31.6kg	35kg/36.5kg

深海洁牌后带扒式吸尘吸水机

SEA CLEAN Wet and Dry Vacuum Cleaner With Squeegee

60 升
60L

塑料桶
Plastic tank

80 升
80L

SC60-2W



SC-603W



SC80-2W



防止泥浆进入马达
Prevent the mud from entering the motor



浮球密封胶套



密封浮球架

浮球密封胶套更密封, 不会在水满浮球浮起时产生吸力, 杜绝污水吸进机头部位。
浮球架360度全密封, 机头角度可以任意调转, 也不会有污水吸进机头部分。

三马达款
Three-motor



SC60-3W



SC-603W-3



SC80-3W

The floating ball sealant sleeve is more sealed, which will not produce suction when the floating ball is full of water, and prevent sewage from being sucked into the machine head.

The floating ball stand is fully sealed in 360 degrees, and the angle of the head can be adjusted at will, and no sewage will be sucked into the head part.

产品特点

- 圆桶型不锈钢 / 塑料桶身, 坚固耐用
- 配备强劲静音型马达, 吸力特强
- 千秋架式倒水, 使用便捷
- 后置式吸水扒, 更快更方便
- 随机附件一应俱全

Features

- The stainless or plastic tank is strong and durable.
- With a powerful lower-noise motor the vacuum cleaner has a special strong suction.
- Has tilted water decove, it is suitable to pour water.
- Has postpositive water sucker, faster and cleaner.
- A complete set of accessories are supplied with the vacuum cleaner.

技术参数 Technical Data

	SC60-2W/SC60-3W	SC-603W/ SC-603W-3	SC80-2W/SC80-3W
功能 Function:	吸尘吸水 wet and dry	吸尘吸水 wet and dry	吸尘吸水 wet and dry
容量 Capacity:	60L	60L	80L
功率 Power:	2000W/3000W	2000W/3000W	2000W/3000W
电压 Voltage:	220V-240V	220V-240V	220V-240V
高度 Height:	97cm	97cm	107cm
桶身直径 Tank diameter:	Φ440mm	Φ440mm	Φ440mm
冷却模式 Mode of cooling:	循环风冷 Circulating air cooling	循环风冷 Circulating air cooling	循环风冷 Circulating air cooling
气流量 Air flow rate:	106L/S 159L/S	106L/S 159L/S	106L/S 159L/S
真空吸力 Vacuum suction:	250mbar	250mbar	250mbar
电源线长 Length of the cable:	8m	8m	8m
配件直径 Hose diameter:	Φ40mm	Φ40mm	Φ40mm
包装规格 Packing:	680×600×1060mm	680×600×1060mm	680×600×1120mm
净重 Net weight:	33.7kg/35.4kg	32kg/33.7kg	35.5kg/37.2kg
毛重 Gross weight:	36.5kg/38.5kg	36.5kg/38.5kg	38kg/40kg

15升1500W马达吸尘吸水机

15L Wet and Dry Vacuum Cleaner



豪华底座
Luxury base

SC-151P

普通底座
Normal base

SC-151NP

技术参数 Technical Data

	SC-151P/SC-151NP
功能 Function:	吸尘吸水 wet and dry
容量 Capacity:	15L
功率 Power:	1500W
电压 Voltage:	220V-240V
高度 Height:	58cm
桶身直径 Tank diameter:	Φ345mm
冷却模式 Mode of cooling:	循环风冷 Circulating air cooling
气流量 Air flow rate:	48L/S
真空吸力 Vacuum suction:	220mbar
电源线长 Length of the cable:	7m
配件直径 Hose diameter:	Φ36mm
包装规格 Packing:	SC-151P: 438×438×650mm SC-151NP: 410×410×640mm
净重 Net weight:	11.9kg/10.9kg
毛重 Gross weight:	13.8kg/12.7kg

产品特点

- 圆桶型不锈钢桶身，坚固耐用
- 配备强劲静音型马达，吸力特强
- 新型大轮盘座，稳重美观
- 随机附件一应俱全

Features

- The stainless tank is strong and durable,
- With a powerful lower-noise motor, the vacuum cleaner has a special strong suction.
- New-style large wheel plate. It is stable and beautiful.
- A complete set of accessories are supplied with the vacuum cleaner.

30升1500W马达吸尘吸水机

30L Wet and Dry Vacuum Cleaner

SC-301NP

普通底座
Normal base



SC-301P

豪华底座
Luxury base



SC-301BP

连体塑料桶
One-body plastic tank



产品特点

- 圆桶型不锈钢 / 塑料桶身, 坚固耐用
- 配备强劲静音型 1500W 马达, 吸力特强
- 新型大轮盘座 / 新型宽大底座, 稳重美观
- 随机附件一应俱全

Features

- The stainless or plastic tank is strong and durable.
- With a powerful lower-noise 1500W motor, the vacuum cleaner has a special strong suction.
- New-style large wheel plate. It is stable and beautiful.
- A complete set of accessories are supplied with the vacuum cleaner.

技术参数 Technical Data

	SC-301P	SC-301NP	SC-301BP
功能 Function:	吸尘吸水 wet and dry	吸尘吸水 wet and dry	吸尘吸水 wet and dry
容量 Capacity:	30L	30L	30L
功率 Power:	1500W	1500W	1500W
电压 Voltage:	220V-240V	220V-240V	220V-240V
高度 Height:	78cm	78cm	76cm
桶身直径 Tank diameter:	Φ345mm	Φ345mm	Φ345mm
冷却模式 Mode of cooling:	循环风冷 Circulating air cooling	循环风冷 Circulating air cooling	循环风冷 Circulating air cooling
气流量 Air flow rate:	53L/S	53L/S	53L/S
真空吸力 Vacuum suction:	240mbar	240mbar	240mbar
电源线长 Length of the cable:	7m	7m	7m
配件直径 Hose diameter:	Φ40mm	Φ40mm	Φ36mm
包装规格 Packing:	438×438×825mm	410×410×815mm	400×400×780mm
净重 Net weight:	13.3kg	12.3kg	12kg
毛重 Gross weight:	15.4kg	14.3kg	13.5kg

60升1500W马达吸尘吸水机

60L Wet and Dry Vacuum Cleaner

SC-602JP

千秋架
Tilt



SC-602SP

豪华底座
Luxury base



产品特点

- 圆桶型不锈钢 / 塑料桶身，坚固耐用
- 配备强劲静音型马达，吸力特强
- SC-602JP 配备千秋架式倒水，使用便捷
- SC-602SP 配备新型大轮盘座，稳重美观
- SC-603JP 桶身耐碰撞，防腐蚀，随时观察污水情况
- 随机附件一应俱全

Features

- The stainless or plastic tank is strong and durable.
- With a powerful lower-noise motor the vacuum cleaner has a special strong suction.
- SC-602J has tilted water decove, it is suitable to pour water.
- SC-603J has a new-style large wheel plate. It is stable and beautiful.
- SC-602B made of semitransparent plastic, the tank is bunn-proof and erosion-proof and the waste water in the tank can be viewed anytime.
- A complete set of accessories are supplied with the vacuum cleaner.

SC-603JP

塑料桶
Plastic tank



技术参数 Technical Data

	SC-602JP	SC-602SP	SC-603JP
功能 Function:	吸尘吸水 wet and dry	吸尘吸水 wet and dry	吸尘吸水 wet and dry
容量 Capacity:	60L	60L	60L
功率 Power:	3000W	3000W	3000W
电压 Voltage:	220V-240V	220V-240V	220V-240V
高度 Height:	97cm	94cm	87cm
桶身直径 Tank diameter:	Φ440mm	Φ440mm	Φ440mm
冷却模式 Mode of cooling:	循环风冷 Circulating air cooling	循环风冷 Circulating air cooling	循环风冷 Circulating air cooling
气流量 Air flow rate:	159L/S	159L/S	159L/S
真空吸力 Vacuum suction:	250mbar	250mbar	250mbar
电源线长 Length of the cable:	8m	8m	8m
配件直径 Hose diameter:	Φ40mm	Φ40mm	Φ40mm
包装规格 Packing:	630×560×1040mm	625×595×1040mm	590×520×995mm
净重 Net weight:	26kg	31kg	24kg
毛重 Gross weight:	27k	31.6kg	25kg

80升1500W马达吸尘吸水机

80L Wet and Dry Vacuum Cleaner

豪华底座
Luxury base

SC-802SP



千秋架
Tilt

SC-802JP



产品特点

- 圆桶型不锈钢桶身，坚固耐用
- 配备强劲静音型马达，吸力特强
- 配备千秋架式倒水，使用便捷
- 配备新型大轮盘座，稳重美观
- 随机附件一应俱全

Features

- The stainless tank is strong and durable.
- With a powerful lower-noise motor the vacuum cleaner has a special strong suction.
- Has tilted water decove, it is suitable to pour water.
- Has a new-style large wheel plate. It is stable and beautiful.
- A complete set of accessories are supplied with the vacuum cleaner.

技术参数 Technical Data

	SC-802JP	SC-802SP
功能 Function:	吸尘吸水 wet and dry	吸尘吸水 wet and dry
容量 Capacity:	80L	80L
功率 Power:	3000W	3000W
电压 Voltage:	220V-240V	220V-240V
高度 Height:	107cm	109cm
桶身直径 Tank diameter:	Φ440mm	Φ440mm
冷却模式 Mode of cooling:	循环风冷 Circulating air cooling	循环风冷 Circulating air cooling
气流量 Air flow rate:	159L/S	159L/S
真空吸力 Vacuum suction:	250mbar	250mbar
电源线长 Length of the cable:	8m	8m
配件直径 Hose diameter:	Φ40mm	Φ40mm
包装规格 Packing:	630×560×1140mm	640×625×1175mm
净重 Net weight:	29kg	30.6kg
毛重 Gross weight:	32kg	34.6kg

90升1500W马达吸尘吸水机

90L Wet and Dry Vacuum Cleaner

塑料桶
Plastic tank

产品特点

- 塑料桶身，坚固耐用
- 配备强劲静音型马达，吸力特强
- 半透明桶身耐碰撞，防腐蚀，随时观察污水情况
- 随机附件一应俱全

Features

- The plastic tank is strong and durable.
- With a powerful lower-noise motor the vacuum cleaner has a special strong suction.
- Made of semitransparent plastic, the tank is bump-proof and erosion-proof and the waste water in the tank can be viewed anytime
- A complete set of accessories are supplied with the vacuum cleaner.



SC-604P

技术参数 Technical Data

功能 Function:
容量 Capacity:
功率 Power:
电压 Voltage:
高度 Height:
桶身直径 Tank diameter:
冷却模式 Mode of cooling:
气流量 Air flow rate:
真空吸力 Vacuum suction:
电源线长 Length of the cable:
配件直径 Hose diameter:
包装规格 Packing:
净重 Net weight:
毛重 Gross weight:

SC-604P
吸尘吸水 wet and dry
90L
3000W
220V-240V
92cm
Φ440mm
循环风冷 Circulating air cooling
159L/S
250mbar
8m
Φ40mm
590×510×995mm
27kg
30.3kg

后带扒式吸尘吸水机

Wet and Dry Vacuum Cleaner With Squeegee

60 升
60L

SC60-2WP



塑料桶
Plastic tank

SC-603WP



80 升
80L

SC80-2WP



产品特点

- 圆桶型不锈钢 / 塑料桶身，坚固耐用
- 配备强劲静音型马达，吸力特强
- 千秋架式倒水，使用便捷
- 后置式吸水扒，更快更干净
- 随机附件一应俱全

Features

- The stainless or plastic tank is strong and durable.
- With a powerful lower-noise motor, the vacuum cleaner has a special strong suction.
- Has tilted water decove, it is suitable to pour water.
- Has postpositive water sucker, faster and cleaner.
- A complete set of accessories are supplied with the vacuum cleaner..

防止泥浆进入马达
Prevent the mud from entering the motor



浮球密封胶套



密封浮球架

浮球密封胶套更密封，不会在水满浮球浮起时产生吸力，杜绝污水吸进机头部位。
浮球架360度全密封，机头角度可以任意调转，也不会有污水吸进机头部分。

The floating ball sealant sleeve is more sealed, which will not produce suction when the floating ball is full of water, and prevent sewage from being sucked into the machine head.

The floating ball stand is fully sealed in 360 degrees, and the angle of the head can be adjusted at will, and no sewage will be sucked into the head part.

技术参数 Technical Data

	SC60-2WP	SC-603WP	SC80-2WP
功能 Function:	吸尘吸水 wet and dry	吸尘吸水 wet and dry	吸尘吸水 wet and dry
容量 Capacity:	60L	60L	80L
功率 Power:	3000W	3000W	3000W
电压 Voltage:	220V-240V	220V-240V	220V-240V
高度 Height:	97cm	97cm	107cm
桶身直径 Tank diameter:	Φ440mm	Φ440mm	Φ440mm
冷却模式 Mode of cooling:	循环风冷 Circulating air cooling	循环风冷 Circulating air cooling	循环风冷 Circulating air cooling
气流量 Air flow rate:	159L/S	159L/S	159L/S
真空吸力 Vacuum suction:	250mbar	250mbar	250mbar
电源线长 Length of the cable:	8m	8m	8m
配件直径 Hose diameter:	Φ40mm	Φ40mm	Φ40mm
包装规格 Packing:	680×600×1060mm	680×600×1060mm	680×600×1120mm
净重 Net weight:	33.7kg	32kg	35.5kg
毛重 Gross weight:	36.5kg	36.5kg	38kg

要选好质量 还是超洁亮
Super Clean Super Quality

Blower &
Accessories

吹风机、配件

系列产品

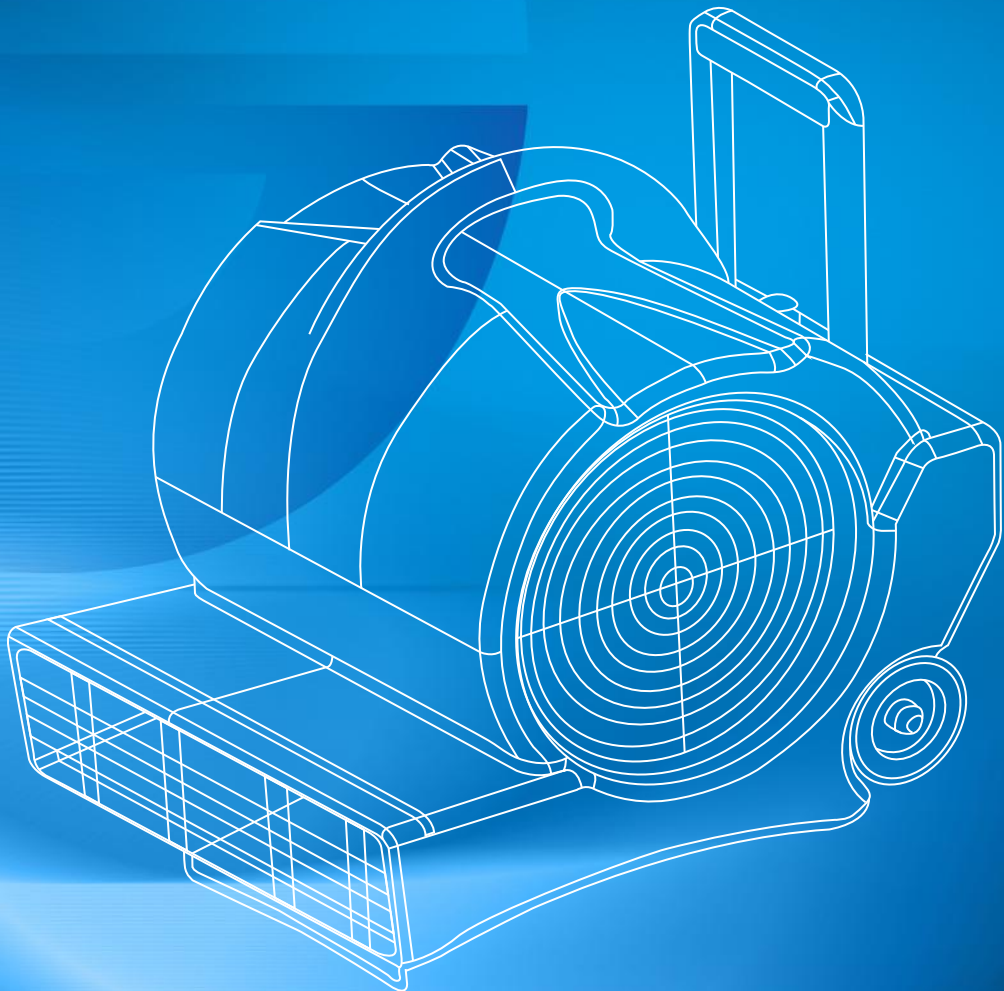

三速电热风机/三速吹风机

3-speed Hot-air Blower/Three-speed blower dryer



钢风轮或塑料风轮配置，三风速档位。
Wind turbines use steel, and three speed can be adjusted.

拉杆设计可上下提拉，方便设备移动使用。

Pull rod can be push-up design convenient for moving.



SC-2900

深海洁牌电热风机

SEA CLEAN Hot-air blower

可配钢风轮或塑料风轮

Wind turbines use steel or plastic



产品特点

- 聚乙烯高强度外壳，美观耐用
- 三档位调速，满足不同环境需要
- SC-2900 三速电热风机装有控温装置，机箱达到一定温度自动断电
- 出风口 < 60°C

Features

- Its housing is made of high strength polyethylene.
- The three-gear speed regulation can satisfy the demands of various conditions.
- Accord with human body safety temperature, thermostat, load protection and the effect is good.
- The outle temperature < 60°C



SC-900

深海洁牌电风机

SEA CLEAN blower



技术参数 Technical Data

	SC-2900	SC-900
功率 Power:	2900W	900W
电压 Voltage:	220-240V~	220-240V~
转速 Rotation speed:	高 High 中 Medium 低 Low	高 High 中 Medium 低 Low
风量 Air flow rate:	140 100 90m ³ /min	160 130 110m ³ /min
电源引线 Cable:	12m	7m
包装规格 Packing:	540×440×555mm	540×440×555mm
毛重 Gross weight:	20.9kg	19.5kg
颜色 Colour:		

三速吹风机

Three-speed blower dryer

KIMBO 牌 / 深海洁牌

AS-900

劲霸牌三速吹风机

THREE-SPEED BLOWER DRYER

产品特点

- 聚乙烯高强度外壳，美观耐用
- 三档位调速，满足不同环境需要

Features

- Its housing is made of high strength polyethylene.
- The three-gear speed regulation can satisfy the demands of various conditions.



SC-900B

深海洁牌三速吹风机

Three-speed blower dryer

技术参数 Technical Data

	AS-900	SC-900B
功率 Power:	900W	900W
电压 Voltage:	220-240V~	220-240V~
转速 Rotation speed:	高 High 中 Medium 低 Low	高 High 中 Medium 低 Low
风量 Air flow rate:	160 130 110m ³ /min	160 130 110m ³ /min
电源引线 Cable:	7m	7m
包装规格 Packing:	540×460×580mm	500×410×490mm
毛重 Gross weight:	19.5kg	17.5kg
颜色 Colour:		

阿美德格抽洗机马达

AMETEK DRY & WET MOTOR



A-043
 119625-00
 抽洗机马达
 Dry & Wet Motor



A-046
 119436-29
 抽洗机马达
 Dry & Wet Motor



A-047
 116513-13
 抽洗机马达
 Dry & Wet Motor



A-048
 119438-29
 抽洗机马达
 Dry & Wet Motor



A-064
 116515-13
 抽洗机马达
 Dry & Wet Motor

技术参数 Technical Data

	A-043	A-046
功率 Power:	1000W	500W
毛重 Gross weight:	14.5kg	13.7kg
电压 Voltage:	240V.AC	24V.DC
包装尺寸 Size:	530×340×230mm	510×340×230mm
包装规格 Packing:	6个 / 箱 6pcs/box 适用于 (Suit for):DTJ1A/SC730A/SC730	6个 / 箱 6pcs/box 适用于 (Suit for):SC25D/SC50D/SC70D/AS1050/SC3A/SC-461

技术参数 Technical Data

	A-047	A-048	A-064
功率 Power:	600W	600W	600W
毛重 Gross weight:	14.5kg	14.5kg	14.5kg
电压 Voltage:	36V.DC	24V.DC	24V.DC
包装尺寸 Size:	530×340×230mm	510×340×230mm	510×340×230mm
包装规格 Packing:	6个 / 箱 6pcs/box 适用于 (Suit for):AS2007	6个 / 箱 6pcs/box 适用于 (Suit for):SC1350/XD860	6个 / 箱 6pcs/box 适用于 (Suit for):XD760B/XD650B/XD510B

阿美德格马达

AMETEK MOTOR



A-050
 119559-00
 吸尘马达
 Dry Motor



A-051
 119656-01
 吸尘吸水马达
 Dry & Wet Motor



A-066A
 133812-00
 吸尘吸水马达
 Dry & Wet Motor



A-066B
 133813-00
 吸尘吸水马达
 Dry & Wet Motor

技术参数 Technical Data

	A-050	A-051	A-066A	A-066B
功率 Power:	1000W	1000W	1000W	1200W
毛重 Gross weight:	13.7kg	14.2kg	12.2kg	12.2kg
电压 Voltage:	220V.AC	240V.AC	220V.AC	220V.AC
包装尺寸 Size:	510×340×230mm	510×340×230mm	510×340×230mm	510×340×230mm
包装规格 Packing:	6个 / 箱 6pcs/box	6个 / 箱 6pcs/box	6个 / 箱 6pcs/box	6个 / 箱 6pcs/box

阿美德格马达

AMETEK MOTOR



A-055
122436-00

吸尘吸水马达
Dry & Wet Motor



A-058
119662-00

吸尘马达
Dry Motor



A-059
119661-00

吸尘吸水马达
Dry & Wet Motor



A-065
116599-13

吸尘马达
Dry Motor

技术参数 Technical Data

	A-055	A-058	A-059	A-065
功率 Power:	1000W	1000W	1000W	500W
毛重 Gross weight:	14.2kg	13.7kg	13.7kg	14.5kg
电压 Voltage:	240V.AC	120V.AC	120V.AC	24V.DC
包装尺寸 Size:	510×340×230mm	510×340×230mm	510×340×230mm	530×340×230mm
包装规格 Packing:	6个 / 箱 6pcs/box	6个 / 箱 6pcs/box	6个 / 箱 6pcs/box	6个 / 箱 6pcs/box

意式马达

CHINA MOTOR

1500W 大功率马达
1500W high power motors



A-053A
GSX-150A
吸尘吸水马达
Dry & Wet Motor



A-053B
GSX-150AL
吸尘吸水马达
Dry & Wet Motor

1000W 大功率马达
1000W power motors



A-045
GX-100A
吸尘马达
Dry Motor



A-049A
GSX-100A
吸尘吸水马达
Dry & Wet Motor



A-049B
GSX-100AL
吸尘吸水马达
Dry & Wet Motor

技术参数 Technical Data

	A-053A	A-053B	A-045	A-049B	A-049A
功率 Power:	1500W	1500W	1000W	1000W	1000W
毛重 Gross weight:	14.5kg	14.5kg	12.5kg	14.5kg	14.5kg
电压 Voltage:	220V.AC	220V.AC	220V.AC	220V.AC	220V.AC
包装尺寸 Size:	510×340×230mm	510×340×230mm	510×340×230mm	510×340×230mm	510×340×230mm
包装规格 Packing:	6个 / 箱 6pcs/box	6个 / 箱 6pcs/box	6个 / 箱 6pcs/box	6个 / 箱 6pcs/box	6个 / 箱 6pcs/box



注：塑料管为 15 升、30 升塑料桶吸尘吸水机专用。

15 升, 20, 30 升吸尘吸水机配件

15L, 20L, 30L wet and dry vacuum cleaner accessories

A-056A

- | | |
|--------|----------------------------|
| ① 直钢管 | ① steel tube |
| ② 圆毛刷 | ② Round brush |
| ③ 尘扒 | ③ Dust vacuuming head |
| ④ 水扒 | ④ water vacuuming head |
| ⑤ 沙发扒头 | ⑤ sofa vacuuming head |
| ⑥ 长扁扒 | ⑥ long flat vacuuming head |
| ⑦ 软管 | ⑦ soft tube |
| ⑧ 短接头 | ⑧ short connector |
| ⑨ 长接头 | ⑨ long connector |

注：15 升单吸尘机不配吸水扒

Note: 15L dust only vacuum cleaner doesn't include ④ water vacuuming head



30 升, 60 升, 80 升, 90 升吸尘吸水机配件

30L, 60L, 80L, 90L wet and dry vacuum cleaner accessories

A-056B

- | | |
|-------|----------------------------|
| ① 弯钢管 | ① steel tube |
| ② 圆毛刷 | ② Round brush |
| ③ 尘扒 | ③ Dust vacuuming head |
| ④ 水扒 | ④ water vacuuming head |
| ⑤ 长扁扒 | ⑤ long flat vacuuming head |
| ⑥ 软管 | ⑥ soft tube |
| ⑦ 长接头 | ⑦ long connector |
| ⑧ 短接头 | ⑧ short connector |

吸尘袋

Dust bag



尘袋规格欢迎客户来样特殊订造
The dust bag's orders with samples are welcome

A-068

布质吸尘袋
Cloth dust bag

A-069

纸质吸尘袋
Paper dust bag

刷机用水箱

Water tank for brush machine



A-008

12L 小水箱
Small Water Tank

A-007A

13L 豪华型大水箱
Big Water Tank

A-009A

13L 中号水箱
Water Tank

技术参数 Technical Data

	A-008	A-007A	A-009A
毛重 Gross Weight:	2kg	2.2kg	2.7kg
尺寸 Size:	270×185×540mm	285×260×490mm	290×210×550mm
包装 Packing:	1 个 / 箱 1 forming/box	1 个 / 箱 1 forming/box	1 个 / 箱 1 forming/box



A-074

小型尘隔 Small dust separator
尺寸 Size: $\Phi 230\text{mm} \times H130\text{mm}$



A-075

中型尘隔 Medium dust separator
尺寸 Size: $\Phi 230\text{mm} \times H220\text{mm}$



A-076

新型中型尘隔
New model medium dust separator
尺寸 Size: $\Phi 230\text{mm} \times H160\text{mm}$

A-019

吸水扒
Water sucker



技术参数 Technical Data

A-019	
净重 Net weight:	3.1kg
毛重 Gross weight:	3.6kg
包装尺寸 Package Size:	800×170×130mm
产品尺寸 Product Size:	780×150×125mm
包装规格 Packing specification:	1个/箱 1bins/box
适用机器 Applicable machines:	SC2A / SC3A / SC3AC / SC50D / SC50C / SC70D / SC70C / AS1050 / AS1050C

A-020

吸水扒
Water sucker

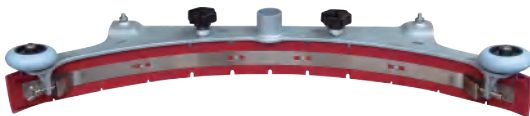

技术参数 Technical Data

A-020	
净重 Net weight:	3.1kg
毛重 Gross weight:	3.6kg
包装尺寸 Package Size:	780×110×230mm
产品尺寸 Product Size:	755×105×210mm
包装规格 Packing specification:	1个/箱 1bins/box
适用机器 Applicable machines:	SC50D / SC50C / SC70D / SC70C / AS1050 / AS1050C / XD-18 / XD-20 / XD-20C / XD-50 / XD-50C / XD-70 / XD-70C / XD-1050 / XD-1050C

卡扣
BUCKLE



A-068A
175 卡扣
175 Buckle



A-068B
154 卡扣
154 Buckle



A-068C
针座盘扣
Pad holder buckle



A-068D
抛光盘扣
Byrnisher plate buckle

适用范围 Suitable machine

A-068A	A-068B
175 机、A-039 机、SC-172 机 175 machine, A-039 mashiche, and SC-172 machine.	154 机、加重翻新机 154 machine and floor renewing machine
A-068C	A-068D
与抛光针座配置使用, 用于固定百洁垫 To be used together with the polishing pad holder surface for fixing the cleaning pad	与抛光针面配置使用, 用于固定抛光垫 To be used together with the polishing needle surface for fastening the polishing mat.

带动盘

DRIVING PLATE



A-071D/A-071D18

154 带动盘
154 Driving plate

A-072D/A-072D18

175 带动盘
175 Driving plate

技术参数 Technical Data				
	A-071D	A-071D18	A-072D	A-072D18
产品尺寸 Product size:	17"	18"	17"	18"
毛重 Gross weight:	2.3kg	2.5kg	2.3kg	2.4kg
尺寸 Size:	380×50×380mm	415×50×415mm	380×50×380mm	415×50×415mm

抛光盘

BURNISHER PLATE



A-073

技术参数 Technical Data	
	A-073
产品尺寸 Product size:	20"
毛重 Gross weight:	1.6kg
尺寸 Size:	500×500×70mm



C-018

地毯吸水钢扒

CARPET WATER SUCKER

技术参数 Technical Data	
产品尺寸 Product size:	Φ38mm
包装尺寸 Packing size:	1580×400×260mm
包装规格 Packing specification:	12个 / 箱 12bins/box

洗地刷

FLOOR BRUSH



A-071A

154 洗地刷
154 Floor brush



A-072A

175 洗地刷
175 Floor brush

技术参数 Technical Data				
	A-071A	A-071A18	A-072A	A-072A18
产品尺寸 Product size:	17"	18"	17"	18"
毛重 Gross weight:	3kg	3.4kg	2.8kg	3kg
尺寸 Size:	385×80×385mm	420×80×420mm	385×80×385mm	420×80×420mm

针座

PAD HOLDER



A-071C

154 针座
154 Pad holder



A-072C

175 针座
175 Pad holder

技术参数 Technical Data

	A-071C	A-071C18	A-072C	A-072C18
产品尺寸 Product size:	17"	18"	17"	18"
毛重 Gross weight:	2kg	2.4kg	2kg	2.3kg
尺寸 Size:	410×65×410mm	435×65×435mm	410×65×410mm	435×65×435mm

地毯刷

CARPET BRUSH



A-071B

154 地毯刷
154 Carper brush



A-072B

175 地毯刷
175 Carper brush



技术参数 Technical Data

	A-071B	A-071B18	A-072B	A-072B18
产品尺寸 Product size:	17"	18"	17"	18"
毛重 Gross weight:	3kg	3kg	2.8kg	3kg
尺寸 Size:	385×80×385mm	420×80×420mm	385×80×385mm	420×80×420mm



A-205

手电钻式抛光机

Hand-held polishing machine



A-057

美国泳池清洁机 (海豚型 -M3)

USA swimming pool cleaner (Dolphin model-M3)

技术参数 Technical Data

	A-205	A-057
功率 Power:	1200W	1000W
转速 Speed:	600-3000r/min	
转盘直径 Rotor plate diameter:	7"	
毛重 Gross weight:	22.5kg	24kg
包装 Packing:	6 台 / 箱 6 forming/box	480×380×440mm

要选好质量 还是超洁亮

Super Clean Super Qualify

Environment
Dustbin Series
环保垃圾桶
系列产品



座地垃圾桶

floor-standing trash bin

B-048

座地垃圾桶

floor-standing trash bin

黑金/黑大理石
Black Gold / Black Marble



玫瑰金/金线米黄大理石
Rose Gold / Golden-Thread
Beige Marble



黑金/金线米黄大理石
Black Gold / Golden-Thread
Beige Marble



玫瑰金/黑白根大理石
Rose Gold / Black and
White Root Marble



砂钢/黑白根大理石
Sand Steel/Black and
White Root Marble



钛金/黑白根大理石
Titanium Gold / Black
and White Root Marble

技术参数 Technical Data

B-048

产品尺寸 Product size:	290×290×720mm
包装尺寸 Packing size:	390×360×820mm
包装规格 Packing specification:	1个 / 箱 1bins/box
毛重 Gross weight:	28k



B-049A
座地垃圾桶
floor-standing
trash bin



B-049B
座地垃圾桶
floor-standing
trash bin



B-050A
座地垃圾桶
floor-standing
trash bin



B-050B
座地垃圾桶
floor-standing
trash bin

技术参数 Technical Data

	B-049A	B-049B	B-050A	B-050B
产品尺寸 Product size:	330×330×770mm	290×290×720mm	330×330×770mm	290×290×720mm
包装尺寸 Packing size:	345×345×790mm	320×320×740mm	345×345×790mm	320×320×740mm
包装规格 Packing specification:	1个 / 箱 1bins/box	1个 / 箱 1bins/box	1个 / 箱 1bins/box	1个 / 箱 1bins/box
毛重 Gross weight:	12k	9k	12k	9k



B-051A
座地垃圾桶
floor-standing
trash bin



B-051B
座地垃圾桶
floor-standing
trash bin



分解图
exploded view

技术参数 Technical Data

	B-051A	B-051B
产品尺寸 Product size:	660×330×770mm	580×290×720mm
包装尺寸 Packing size:	680×345×790mm	600×320×740mm
包装规格 Packing specification:	1个 / 箱 1bins/box	1个 / 箱 1bins/box
毛重 Gross weight:	22kg	17k



B-052A / B-052B
黑金/花石大理石
Black Gold / Flower
Stone Marble



B-054A / B-054B
黑金/黑白根大理石
Black Gold / Black and White
Root Marble



B-056A / B-056B
黑金/灰木纹大理石
Black Gold / Gray Wood
Grain Marble



B-053A / B-053B
玫瑰金/花石大理石
Rose Gold / Flower
Stone Marble



B-055A / B-055B
玫瑰金/黑白根大理石
Rose Gold / Black and White
Root Marble



B-057A / B-057B
玫瑰金/灰木纹大理石
Rose Gold / Gray Wood
Grain Marble

技术参数 Technical Data

	B-052A/B-053A/B-054A/B-055A/B-056A/B-057A	B-052B/B-053B/B-054B/B-055B/B-056B/B-057B
产品尺寸 Product size:	250×250×730mm	280×280×760mm
包装尺寸 Packing size:	390×360×820mm	390×360×820mm
包装规格 Packing specification:	1个 / 箱 1bins/box	1个 / 箱 1bins/box
毛重 Gross weight:	34k	34k



B-001
60 升四轮移动垃圾桶
60L Four-wheel Movable
Garbage Bin



B-002
100 升侧轮垃圾桶
100L Side-wheel
Garbage Bin



B-003
120 升侧轮垃圾桶
120L Side-wheel
Garbage Bin



B-004
240 升侧轮垃圾桶
240L Side-wheel
Garbage Bin



B-001A
60 升脚踏式垃圾桶
60L Foot-pedal
Garbage Bin



B-002A
100 升脚踏式侧轮垃圾桶
100L Foot-pedal
Side-wheel Garbage Bin



B-003A
120 升脚踏式侧轮垃圾桶
120L Foot-pedal
Side-wheel Garbage Bin



B-004A
240 升脚踏式侧轮垃圾桶
240L Foot-pedal
Side-wheel Garbage Bin

产品特点

- 全新优质塑料制成，桶身坚厚平滑，易于清理。
- 外形美观大方，重心负载脚轮，纯橡胶制造；轻巧静音，嵌入式安装，绝不松脱。
- 可轻松跨越梯级或路边石阶。
- 一体成型的结构使其具有卓越的强度及耐用性。
- 适用于各类公共场所的废弃物收集或原料搬运。





Features

- The products are made of high-graded plastic.
- The bins are thick and the surface is smooth, easy cleaning. The products have a beautiful appearance and are durable.
- The heavy-load foot wheels are made of pure rubber, being light and making no noise.
- The wheels are embedded in the bin, so they never get off and can easily get over stairs and curbs.
- The one-piece structure makes it remarkably strong and durable.
- They are suitable for collecting garbage in public sites or for material

技术参数 Technical Data

	B-001/B-001A	B-002/B-002A	B-003/B-003A	B-004/B-004A
容量 Capacity:	60L	100L	120L	240L
产品尺寸 Product size:	410×480×680mm	480×550×800mm	480×550×930mm	720×570×1030mm
包装尺寸 Packing size:	500×420×1030mm	560×500×1130mm	560×500×1235mm	740×590×1290mm
包装规格 Packing specification:	5 个 / 箱 5bins/box	3 个 / 箱 3bins/box	3 个 / 箱 3bins/box	3 个 / 箱 3bins/box
毛重 Gross weight:	21.5kg 25.5kg	29kg 31kg	32kg 34.5kg	45.5kg 48.2kg
颜色 Colour:				



技术参数 Technical Data	B-031	B-032	B-033	B-034	B-035
容量 Capacity:	42L	23L	42L	23L	13L
产品尺寸 Product size:	430×294×655mm	380×280×512mm	387×283×502mm	368×270×379mm	291×207×303mm
包装尺寸 Packing size:	590×410×810mm	575×390×650mm	580×400×660mm	545×380×710mm	435×300×610mm
包装规格 Packing specification:	10个 / 箱 10bins/box	10个 / 箱 10bins/box	10个 / 箱 10bins/box	20个 / 箱 20bins/box	20个 / 箱 20bins/box
毛重 Gross weight:	20.5kg	16kg	15.5kg	21kg	6.9kg
颜色 Colour:					

58L



B-016A
58 升废纸收集桶 A
58L Waste Paper
Gathering bin A



B-016B
58 升废纸收集桶 B
58L Waste Paper
Gathering bin B



B-016C
58 升废纸收集桶 C
58L Waste Paper
Gathering bin C

技术参数 Technical Data

	B-016A	B-016B	B-016C
容量 Capacity:	58L	58L	58L
产品尺寸 Product size:	460×320×805mm	460×320×805mm	460×320×805mm
包装 Packing:	630×480×795mm	630×480×795mm	630×480×795mm
包装规格 Packing specification:	6 个 / 箱 6bins/box	6 个 / 箱 6bins/box	6 个 / 箱 6bins/box
毛重 Gross weigh	19.5kg	19.5kg	19.5kg
颜色 Colour:			

58L



B-016D
58 升弹盖收集桶
58L Turning Cover
Gathering Bin





B-016E
58 升弹盖烟灰垃圾桶
58L Turning Cover
Gathering Bin

技术参数 Technical Data

	B-016D	B-016E
容量 Capacity:	58L	58L
产品尺寸 Product size:	460×320×805mm	460×320×805mm
包装 Packing:	630×480×795mm	630×480×795mm
包装规格 Packing specification:	6 个 / 箱 6bins/box	6 个 / 箱 6bins/box
毛重 Gross weight:	20.3kg	20.5kg
颜色 Colour:		







技术参数 Technical Data

	B-013	B-014	B-015
容量 Capacity:	58L	42L	23L
产品尺寸 Product size:	475×328×752mm	418×318×630mm	310×250×529mm
包装 Packing:	630×480×885mm	590×400×790mm	400×290×970mm
包装规格 Packing specification:	8 个 / 箱 8bins/box	10 个 / 箱 10bins/box	10 个 / 箱 10bins/box
毛重 Gross weight:	26.5kg	19.5kg	16kg
颜色 Colour:			



技术参数 Technical Data

	B-029	B-034B	B-035B	B-030B
容量 Capacity:	12L	12L	8L	8L
产品尺寸 Product size:	295×210×310mm	295×210×310mm	260×175×260mm	260×175×260mm
包装 Packing:	450×300×630mm	585×430×508mm	530×360×400mm	340×245×695mm
包装规格 Packing specification:	20 个 / 箱 20bins/box	20 个 / 箱 20bins/box	20 个 / 箱 20bins/box	20 个 / 箱 20bins/box
毛重 Gross weight:	12.6kg	12.5kg	6.9kg	9.6kg
颜色 Colour:				

9L



B-236A

9 升小号阻燃垃圾桶
9 Plastic Dustbin

10L



B-236B

10 升中号阻燃垃圾桶
10L Plastic Dustbin

技术参数 Technical Data

	B-236A	B-236B
容量 Capacity:	9L	10L
产品尺寸 Product size:	265×200×275mm	265×200×320mm
包装 Packing:	525×400×615mm	535×405×660mm
包装规格 Packing specification:	20 个 / 箱 20bins/box	20 个 / 箱 20bins/box
毛重 Gross weight:	11.6kg	12.9kg
颜色 Colour:		

450L



B-110A

450 升手推式倾斜斗车
450L Tilt Container

350L



B-110B

350 升手推式倾斜斗车
350L Tilt Container

660L



B-109

660 升户外垃圾车
660L Outdoor Garbage Cart

技术参数 Technical Data

	B-110A	B-110B	B-109
容量 Capacity:	450L	350L	660L
产品尺寸 Product size:	1450×750×1050mm	1380×600×900mm	1250×760×1200mm
颜色 Colour:			

B-040/B-040B/B-040D/B-040E

单桶榨水车

Single Mop Wringer Trolley



B-040



B-040B







B-040D



B-040E

技术参数 Technical Data

	B-040	B-040B	B-040D	B-040E
容量 Capacity:	36L	32L	32L	36L
产品尺寸 Product size:	550×390×910mm	540×380×900mm	540×380×900mm	550×390×910mm
包装 Packing:	510×425×360mm	510×405×360mm	510×425×360mm	510×425×360mm
包装规格 Packing specification:	1个 / 箱 1PC/box	1个 / 箱 1PC/box	1个 / 箱 1PC/box	1个 / 箱 1PC/box
毛重 Gross weight:	8.2kg	7.5kg	7.5kg	8.2kg
颜色 Colour:				

B-046/B-046B

下压式双桶榨水车

Down-press Double Mop Wringer Trolley



B-046



B-046B

技术参数 Technical Data

	B-046	B-046B
大桶容量 Big bucket capacity:	35L	35L
中桶容量 Middle bucket capacity:	15L	--
小桶容量 Small bucket capacity:	4L	4L
包装 Packing:	920×440×400mm	510×370×530mm
包装规格 Packing specification:	1个 / 箱 1PC/box	1个 / 箱 1PC/box
毛重 Gross weight:	13.5kg	8.8kg

B-038

轻便式单桶榨水车

Wringer Trolley

技术参数 Technical Data

B-038	
容量 Capacity:	20L
产品尺寸 Product size:	400×270×340mm
包装 Packing:	465×270×290mm
包装规格 Packing specification:	1个 / 箱 1PC/box
毛重 Gross weight:	4.3kg



B-038



B-043A

B-043A\B-043

下压式双桶榨水车

Down-press Double Mop Wringer Trolley

弯手把
Curved Handle



B-043

侧压式双桶榨水车

Side-press Double Mop Wringer Trolley

技术参数 Technical Data

	B-043A	B-043
容量 Capacity:	50L	50L
产品尺寸 Product size:	880×420×800mm	880×420×800mm
包装 Packing:	810×410×385mm	810×410×385mm
包装规格 Packing specification:	1个 / 箱 1PC/box	1个 / 箱 1PC/box
毛重 Gross weight:	10.5kg	10.5kg

B-042

打蜡桶

Cleaning Wax Barrel

技术参数 Technical Data

B-042

产品尺寸 Product size:	514×267×330mm
包装 Packing:	580×580×880mm
包装规格 Packing specification:	10 个 / 箱 10bins/box
容量 Capacity:	26L
毛重 Gross weight:	23.5kg
颜色 Colour:	



B-041

双格桶

Twin Bucket



技术参数 Technical Data

B-041

产品尺寸 Product size:	368×457×254mm
包装 Packing:	730×465×510mm
包装规格 Packing specification:	12 个 / 箱 12PC/box
容量 Capacity:	18L
毛重 Gross weight:	16.5kg
颜色 Colour:	

B-039B

小号手提工具篮

Tool Basket(S)

技术参数 Technical Data

B-039B

产品尺寸 Product size:	381×273×175mm
包装 Packing:	570×400×580mm
包装规格 Packing specification:	20 个 / 箱 20bins/box
毛重 Gross weight:	11.4kg
颜色 Colour:	



告示牌

Caution Board

B-131~B-149

A 字型告示牌

Caution Board



B-131



B-132



B-133



B-134



B-136



B-137



B-138



B-139



B-140



B-141



B-142



B-143



B-144



B-135



B-146



B-147



B-148



B-149

技术参数 Technical Data

材质 Material:	PP 料 / PP materia
产品尺寸 Product size:	295×25×620mm
包装 Packing:	315×275×650mm
包装规格 Packing specification:	10 块 / 箱 10Pieces/box
毛重 Gross weight:	7.3kg
颜色 Colour:	黄色

全新优质塑料注塑成型。产品分 ABS 料和 PP 料两种。外观光洁平整精美厚实。产品不老化变形，高温暴晒及低温严寒情况下使用，一样历久如新。警示图案及字样清晰。配有中英文字体，款式多种多样。适用于宾馆、酒店及各种公共场所使用。欢迎客户来样定制字样。

The product is made of brand new ABS or PP plastic material through injection mould. It has a sheeny and smooth surface, it is being strong and beautiful. The product doesn't get aged and deformed. Even placed in an environment of high temperature, under insolation or in vigorous winter it still keeps new after use a long time. The text in Chinese and English pattern on it are clear. There are many designs of this product. It is suitable for hotels, restaurants and other public sites. Orders with samples or texts are welcome.

告示牌

Caution Cone

B-111~B-121

矮身直立式告示牌

Small Caution Cone



B-111



B-112



B-113



B-114



B-115



B-116



B-117



B-118



B-119



B-120



B-121

技术参数 Technical Data

材质 Material:	PP料 /PP materia
产品尺寸 Product size:	340×320×930mm
包装 Packing:	345×320×940mm
包装规格 Packing specification:	6块 / 箱 6Pieces/box
毛重 Gross weight:	8.8kg
颜色 Colour:	

B-122~B-130

高身直立式告示牌

Large Caution Cone



B-122



B-123



B-124



B-125



B-126



B-127



B-128



B-129



B-130

技术参数 Technical Data

材质 Material:	PP料 /PP materia
产品尺寸 Product size:	320×320×1170mm
包装 Packing:	325×325×1205mm
包装规格 Packing specification:	6块 / 箱 6Pieces/box
毛重 Gross weight:	15.8kg
颜色 Colour:	

全新优质塑料注塑成型。外观光洁平整，精美厚实，稳重大方。产品不老化变形，高温暴晒及低温严寒情况下使用，一样历久如新。警示牌与锥体结合紧密牢固。图案及字样清晰明了。配有中英文字体，款式多种多样。适用于宾馆、酒店及各种公共场所使用。欢迎客户来样定制字样。

The product is made of brand new through injection mould. It has a sheeny and smooth surface. It is strong and beautiful and stable. The product doesn't get aged and deformed. Even placed in an environment of high temperature, under insolation or in vigorous winter it still keeps new after use a long time. The signboard and the cone combine firmly. The text in Chinese and English pattern on it are clear. There are many designs of this product. It is suitable for hotels, restaurants and other public sites. Orders with samples or texts are welcome.



B-150 折叠停车牌

foldable parking sign

技术参数 Technical Data

材质 Material:	201不锈钢 / 201 stainless steel
产品尺寸 Product size:	430×550×580mm
包装 Packing:	410×360×670mm
包装规格 Packing specification:	5个 / 箱 5Pieces/box
毛重 Gross weight:	1.85kg

E-001 伸缩栏杆座

retractable stanchion

技术参数 Technical Data

材质 Material:	201不锈钢/铁烤漆 201 stainless steel/iron with baked coating
产品尺寸 Product size:	ø320×900mm
包装 Packing:	
杆身 shaft	
包装 Packing:	865×335×270mm
包装规格 Packing specification:	20根/箱 20roots/box
毛重 Gross weight:	15.31kg/箱 15.31kg/box
底座面盖 base face cover:	
包装 Packing:	650×320×210mm
包装规格 Packing specification:	20个/箱 20 pcs/box
毛重 Gross weight:	5.5kg/箱 5.5kg/box



底座 base	
包装 Packing:	310×310×210mm
包装规格 Packing specification:	5个/箱 5pcs/box
毛重 Gross weight:	23.5kg/箱 23.5kg/box



E-002

圆座栏杆座
round-based
stanchion

E-003

黑金柱栏杆座
black-gold column
stanchion

E-004

皇冠头栏杆座
crown-headed
stanchion

技术参数 Technical Data

材质 Material:	201不锈钢/铁烤漆 201 stainless steel/iron with baked coating
杆身 shaft	
包装 Packing:	810×320×240mm
包装规格 Packing specification:	20根/箱 20roots/box
毛重 Gross weight:	112.21kg/箱 112.21kg/box
底座面盖 base face cover:	
包装 Packing:	650×320×210mm
包装规格 Packing specification:	20个/箱 20pcs/box
毛重 Gross weight:	5.5kg/箱 5.5kg/box
底座 base	
包装 Packing:	310×310×210mm
包装规格 Packing specification:	5个/箱 5pcs/box
毛重 Gross weight:	23.5kg/箱 23.5kg/box



E-005 立牌指示牌

standing direction sign

技术参数 Technical Data

材质 Material:	201不锈钢/201 stainless steel
产品尺寸 Product size:	
外框尺寸 Outer frame dimensions	350×450mm
高度 Height	920-1350mm
底座直径 Base diameter	ø320mm
包装尺寸 Packaging size	
A3牌 A3board	460×350×360mm 10个/箱 15.4KG/箱 460×350×360mm 110pcs/box 15.4kg/box
杆身 Shaft	650×360×140mm 10根/箱 8KG/箱 650×360×140mm 10 pcs/box 8kg/box
底座 Base	310×310×210mm 5个/箱 23.5KG/箱 310×310×210mm 5 pcs/box 23.5kg/box

要选好质量 还是超洁亮

Super Clean Super Qualify

Cleaning Tools
Series

清洁工具

系列产品

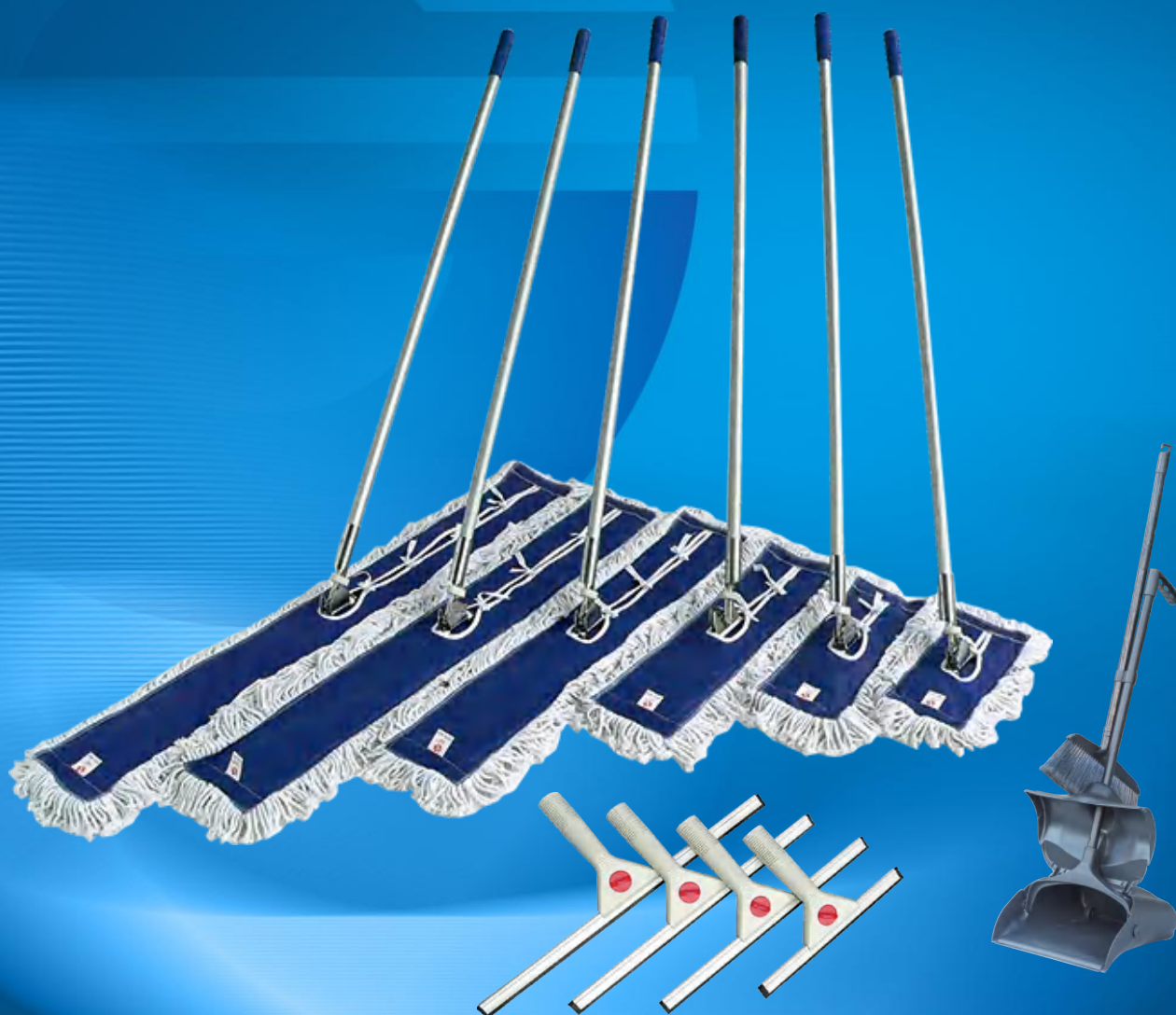

尘推

Lobby Mop

C-007/C-008/C-009
C-010/C-011/C-012
标准型大堂尘推
Standard Lobby Mop



C-012 C-011 C-010 C-009 C-008 C-007

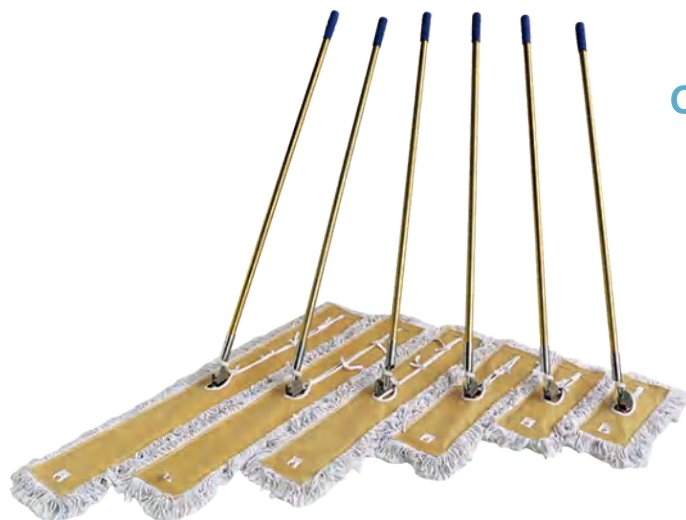

C-001/C-002/C-003
C-004/C-005/C-006
豪华型大堂尘推
Luxury Lobby Mop

C-006 C-005 C-004 C-003 C-002 C-001

尘推均可配 1.2m、1.25m
With handle of 1.2m or 1.25m

技术参数 Technical Data						
豪华型大堂尘推 Luxury lobby mop	C-001	C-002	C-003	C-004	C-005	C-006
产品尺寸 Product size:	12" (300×160mm)	16" (400×160mm)	24" (600×160mm)	36" (900×160mm)	42"(1100×160mm)	48"(1200×160mm)
包装尺寸 Packing size:	400×390×290mm	470×390×290mm	670×390×290mm	970×390×290mm	1160×390×290mm	1270×390×290mm
包装规格 Packing specification:	25个 / 箱 25pcs/box	25个 / 箱 25pcs/box	25个 / 箱 25pcs/box	25个 / 箱 25pcs/box	25个 / 箱 25pcs/box	25个 / 箱 25pcs/box
整箱毛重 Gross weight:	14.5kg	16kg	22.5kg	30.5kg	36kg	43.5kg

技术参数 Technical Data						
标准型大堂尘推 Standard lobby mop	C-007	C-008	C-009	C-010	C-011	C-012
产品尺寸 Product size:	12" (300×160mm)	16" (400×160mm)	24" (600×160mm)	36" (900×160mm)	42"(1100×160mm)	48"(1200×160mm)
包装尺寸 Packing size:	400×390×280mm	460×390×280mm	660×390×280mm	960×390×280mm	1160×390×280mm	1270×390×280mm
包装规格 Packing specification:	25个 / 箱 25pcs/box	25个 / 箱 25pcs/box	25个 / 箱 25pcs/box	25个 / 箱 25pcs/box	25个 / 箱 25pcs/box	25个 / 箱 25pcs/box
整箱毛重 Gross weight:	11kg	15kg	20kg	27.5kg	33.5kg	40.3kg

纱线含棉量高，股束紧密，集尘能力强。能经得起反复洗涤，不易散脱。合成纤维质料背衬，耐磨性高，易磨损部位特设加厚层，经久耐用。
The yarn has a high content of cotton. The strands are closely made. It is good at collecting dust. Repeating washing won't make it loose. The back lining is made of synthetic fibre. It is highly abrasion-proof. The part that is easy to wear is thickened, allowing a long use.

地拖

Mop

C-016

豪华型扣式地拖
Luxury Clip Mop



C-013

豪华型地拖
Luxury Mop



C-202

豪华型夹紧式地拖
Luxury Clamping Mop



C-204

豪华型压紧式地拖
Luxury Pressing Mop



C-203A

压紧式地拖夹
Pressing Mop



C-201A

夹紧式地拖夹
Clamping Mop



C-014A

标准型地拖夹
Clamping Mop



C-015A

扣式地拖夹
Clip Mop

C-203

标准型压紧式地拖
Standard Pressing Mop



C-201

标准型夹紧式地拖
Standard Clamping Mop



C-014

标准型地拖
Standard Mop



C-015

标准型扣式地拖
Standard Clip Mop



彩色地拖

Colorful Mop



C-205

标准型彩杆压紧式地拖
Standard Colourful Pressing Mop



C-206

豪华型彩杆压紧式地拖
Luxury Colourful Pressing Mop



C-207

B型彩杆压紧式地拖
B Colourful Pressing Mop



四色可选
Four Color For Choose



C-208

40CM平板拖把
40CM Flat Mop



C-013E

标准型地拖头
Normal Mop Head



C-013F

豪华型地拖头
Luxury Mop Head



C-013G

B型地拖头
B Mop Head

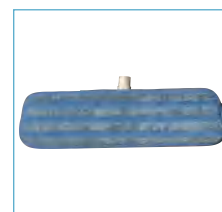

C-208A

尘推平板配布
Dust Extractor Flat Cloth

技术参数 Technical Data

	C-013E	C-013F	C-013G
包装尺寸 Packing size	880×380×360mm	450×330×400mm	880×400×350mm
整箱毛重 Gross Weight	22kg	9kg	24.5kg
包装规格 Packing specification	50套 / 箱 50bins/box	20套 / 箱 20bins/box	50套 / 箱 50bins/box

技术参数 Technical Data

	C-208	C-208A
包装尺寸 Packing size:	1340×335×180mm	520×420×420mm
整箱毛重 Gross Weight:	13kg	17.9kg
包装规格 Packing specification:	50把 / 箱 50bins/box	50个 / 箱 50pcs/box

所有地拖配件不做纸箱，只针对地拖头包装
Only packing for the mop heads

垃圾收集工具 Garbage Collection Tools



C-019

 塑料防风垃圾铲
 Plastic Shovel With Hendrall

C-019C

 塑料防风垃圾铲
 Plastic Shovel With Hendrall

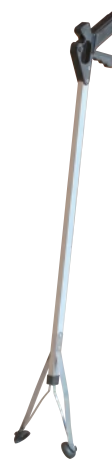
C-019D

 塑料防风垃圾铲 (带扫把)
 Plastic Shovel With Hendrall

C-300A

 捡拾器
 Pick Up Tool

技术参数 Technical Data

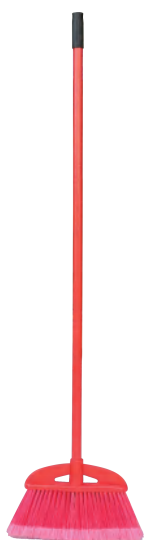
	C-019	C-019C	C-019D	C-300A
包装尺寸 Packing size:	820×330×400mm	820×330×400mm	820×330×400mm	900×350×215mm
整箱毛重 Gross Weight:	15kg	15kg	15kg	7.2kg
包装规格 Packing specification:	12套 / 箱 12bins/box	12个 / 箱 12pcs/box	12套 / 箱 12bins/box	60个 / 箱 60pcs/box
颜色 Colour:	■	■	■	■

C-021

 长柄扫把
 Long Broom

C-021A

 长柄扫把
 Long Broom

C-022B

 短柄扫把
 Short Broom

C-022

 短柄扫把
 Short Broom

C-022B、C-022 可配套 C-019C 防风垃圾铲
 C-022B and C-022 can completed with C-019C
 plastic shovel with handrall.

技术参数 Technical Data

	C-021 头head	C-021 杆handle	C-021A 头head	C-021A 杆handle	C-022	C-022B
包装尺寸 Packing size:	854×290×190mm	1230×230×140mm	810×250×180mm	1230×230×140mm	920×260×200mm	760×250×250mm
高度 Height:	--	1200mm	--	1200mm	950mm	780mm
包装规格 Packing specification:	12个 / 箱 12pcs/box	72把 / 箱 72bins/box	24个 / 箱 24pcs/box	24把 / 箱 24bins/box	30套 / 箱 30bins/box	30把 / 箱 30pcs/box
颜色 Colour:	■	■	■	■	■	■

五色扫把

Multicolored Broom

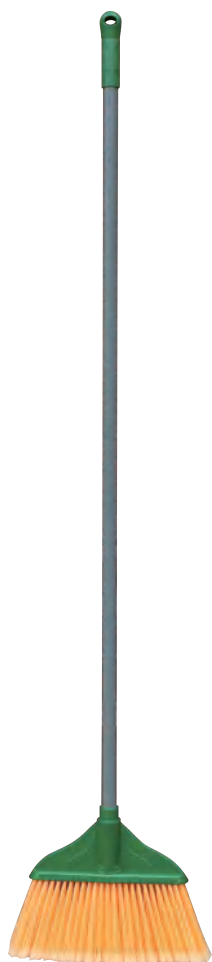

C-509A
五色扫把
Multicolored Broom

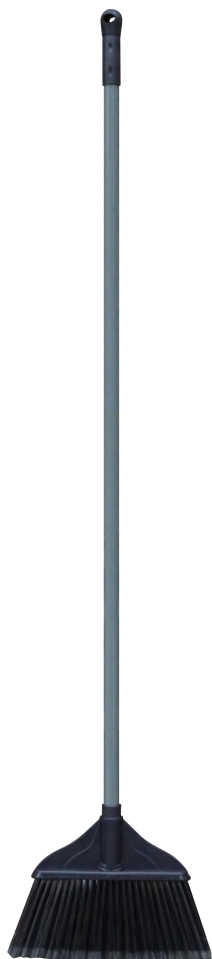

C-509B
五色扫把
Multicolored Broom

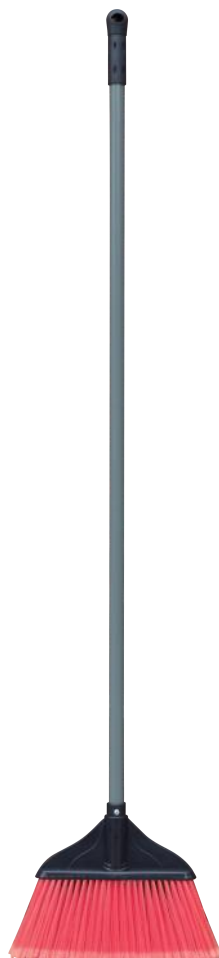

C-509C
五色扫把
Multicolored Broom

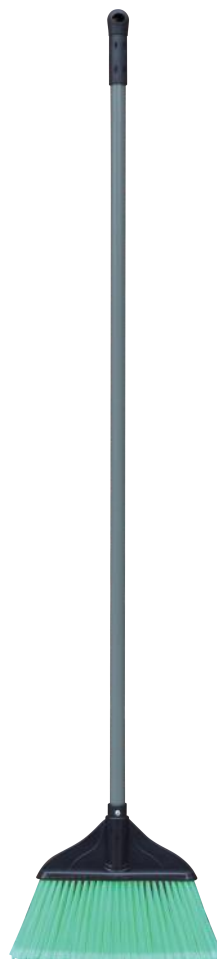

C-509D
五色扫把
Multicolored Broom

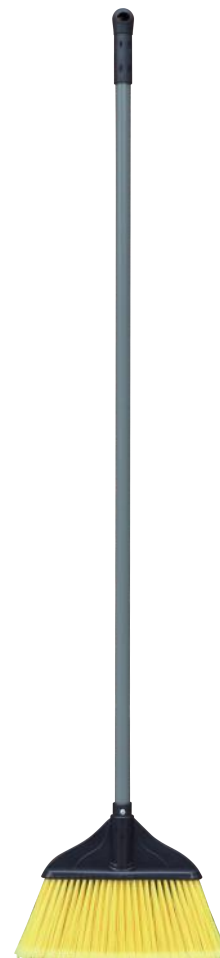

C-509E
五色扫把
Multicolored Broom



手柄套可旋转
revolving grip for
handwheel

技术参数 Technical Data

	C-509A / C-509B / C-509C / C-509D / C-509E 头head	C-509A / C-509B / C-509C / C-509D / C-509E 杆handle
包装尺寸 Packing size	820×270×220mm	122×203×140mm
整箱毛重 Gross Weight	7.3kg	6.3kg
包装规格 Packing specification	24套 / 箱 24bins/box	24套 / 箱 24bins/box

玻璃刮/涂水器

Glass Scrape and Water Scrape

塑料铝合金玻璃刮

Glass-alloy Scrape

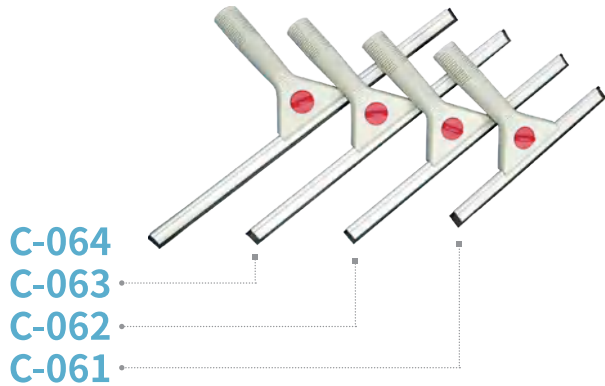

不锈钢玻璃刮

Stainless Steel Glass Scrape

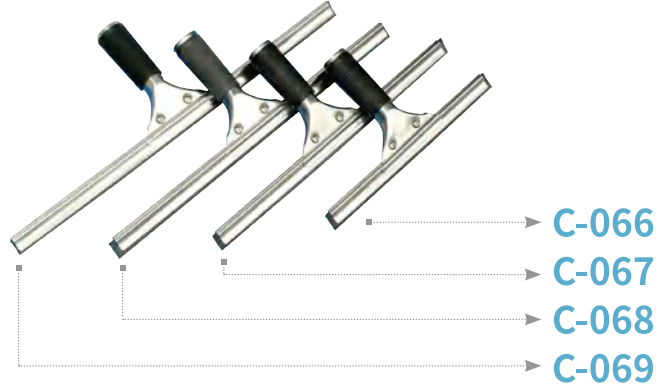

技术参数 Technical Data

	C-069	C-068	C-067	C-066
刮条长度 Scrape length:	18" 45cm	16" 40cm	14" 35cm	10" 25cm
包装尺寸 Packing size:	470×250×145mm	425×250×150mm	380×250×180mm	280×250×220mm
包装规格 Packing specification:	50套 / 箱 50bins/box	50套 / 箱 50bins/box	50套 / 箱 50bins/box	50套 / 箱 50bins/box
整箱毛重 Gross Weight:	11kg	9.5kg	8.9kg	7.6kg
颜色 Colour:				

	C-064	C-063	C-062	C-061
刮条长度 Scrape length:	18" 45cm	16" 40cm	14" 35cm	10" 25cm
包装尺寸 Packing size:	470×360×140mm	425×360×140mm	425×360×140mm	425×360×140mm
包装规格 Packing specification:	50套 / 箱 50bins/box	50套 / 箱 50bins/box	50套 / 箱 50bins/box	50套 / 箱 50bins/box
整箱毛重 Gross Weight:	7.5kg	6.5kg	6kg	5.5kg

涂水器

Glass Water Scrape

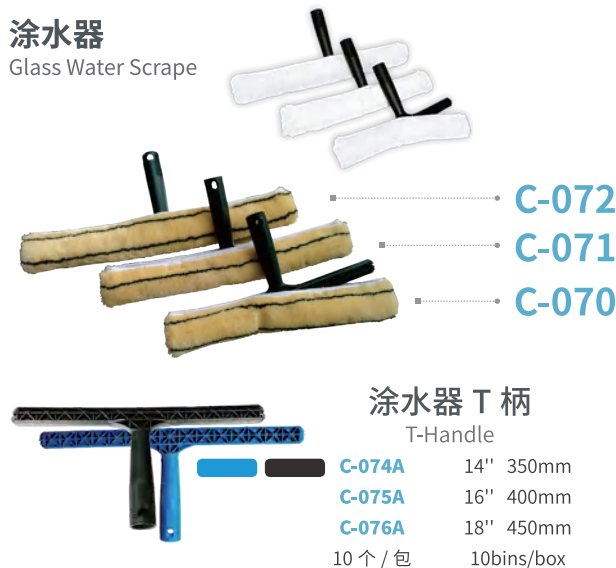

双用玻璃清洁工具

Double Window Cleaner
Window Washer and Squeegee



涂水器 T 柄

T-Handle

C-074A	14" 350mm
C-075A	16" 400mm
C-076A	18" 450mm
10个 / 包	10bins/box

涂水器毛头

Spare for Glass Water Scrape

C-074	14" 350mm
C-075	16" 400mm
C-076	18" 450mm
10个 / 包	10bins/box

技术参数 Technical Data

	C-070	C-071	C-072	C-073
毛头长度 Spare length:	14" 35cm	16" 40cm	18" 45cm	16" 40cm
包装尺寸 Packing size:	520×380×380mm	540×430×380mm	560×480×380mm	420×410×430mm
包装规格 Packing specification:	50套 / 箱 50bins/box	50套 / 箱 50bins/box	50套 / 箱 50bins/box	30套 / 箱 30bins/box
整箱毛重 Gross Weight:	9.1kg	10kg	11.3kg	10.6kg
颜色 Colour:				

推水刮 Squeegee

钢板直胶推水刮
Steel curved squeegee



C-025
C-024
C-023

钢板弯胶推水刮
Steel straight squeegee



C-028
C-027

技术参数 Technical Data

	C-023	C-024	C-025	C-027	C-028
包装尺寸 Packing size:	450×255×100mm	550×255×100mm	750×255×120mm	540×255×135mm	740×255×135mm
刮条长度 Scrape length:	18" 450mm	22" 550mm	30" 750mm	22" 550mm	30" 750mm
包装规格 Packing specification:	25 个 / 箱 25bins/box	25 个 / 箱 25bins/box	30 个 / 箱 30bins/box	30 个 / 箱 30bins/box	30 个 / 箱 30bins/box
整箱毛重 Gross Weight:	14kg	18.5kg	27kg	20kg	26.5kg

钢板直绵推水刮
Steel straight squeegee

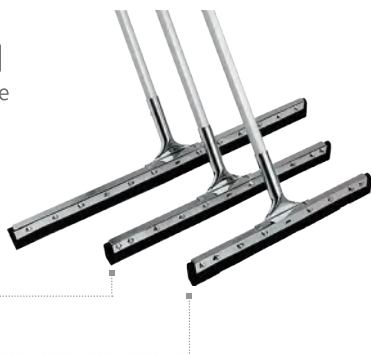

C-031
C-030
C-029

钢板弯绵推水刮
Steel curved squeegee



C-033
C-034

技术参数 Technical Data

	C-029	C-030	C-031	C-033	C-034
包装尺寸 Packing size:	470×270×275mm	570×270×275mm	770×270×275mm	570×220×190mm	760×280×325mm
刮条长度 Scrape length:	18" 450mm	22" 550mm	30" 750mm	22" 550mm	30" 750mm
包装规格 Packing specification:	50 个 / 箱 50pcs/box	50 个 / 箱 50pcs/box	50 个 / 箱 50pcs/box	20 个 / 箱 20pcs/box	50 个 / 箱 50pcs/box
整箱毛重 Gross Weight:	18kg	21.6kg	29.5kg	9kg	28.5kg

塑料海绵推水刮
Plastic sponge squeegee

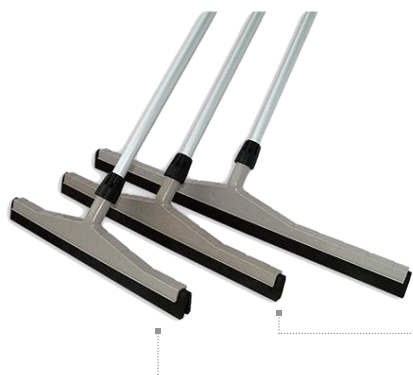

C-037
C-036
C-035

技术参数 Technical Data

	C-035	C-036	C-037
包装尺寸 Packing size:	500×280×420mm	590×280×420mm	790×280×420mm
刮条长度 Scrape length:	18" 450mm	22" 550mm	30" 750mm
包装规格 Packing specification:	20 个 / 箱 20pcs/box	20 个 / 箱 20pcs/box	20 个 / 箱 20pcs/box
整箱毛重 Gross Weight:	5.8kg	6.8kg	8.4kg

伸缩杆

Telescopic Aluminum Lever

铝合金伸缩杆通水刷

Aluminum Alloy Telescopic Rod Water Brush

C-507

C-508



铝合金**两节**伸缩杆通水刷
Two Telescopic Cleaning Brush

铝合金**三节**伸缩杆通水刷
Three Telescopic Cleaning Brush

技术参数 Technical Data

	C-507	C-508
产品特性 Product features:	蓝刷 Blue brush	蓝刷 Blue brush
通水刷尺寸 Brush size:	680×275×270mm	680×275×270mm
通水刷毛重 Brush Weight:	7.4kg	6.5kg
伸缩杆尺寸 Telescopic pole:	1660mm 1050×165×125mm	3400mm 1480×200×125mm
伸缩杆毛重 Telescopic Weight:	4.6kg	13.5kg
包装规格 Packing specification:	12个 / 箱 12pcs/ctn	12个 / 箱 12pcs/ctn

铝合金伸缩杆

Telescopic Aluminum Lever

颜色 Colour:



- C-044 0.6M 单节 Single Level
- C-045 1.2M 单节 Single Level
- C-046 1.2M 双节 Two Level
- C-047 2.4M 双节 Two Level
- C-048 3.0M 双节 Two Level
- C-049 3.6M 双节 Two Level
- C-050 4.0M 双节 Two Level

- C-051 4.5M 双节 Two Level
- C-052 3.6M 三节 Three Level
- C-053 4.0M 三节 Three Level
- C-054 4.5M 三节 Three Level
- C-055 6.0M 三节 Three Level
- C-056 8.0M 三节 Three Level
- C-057 9.0M 三节 Three Level

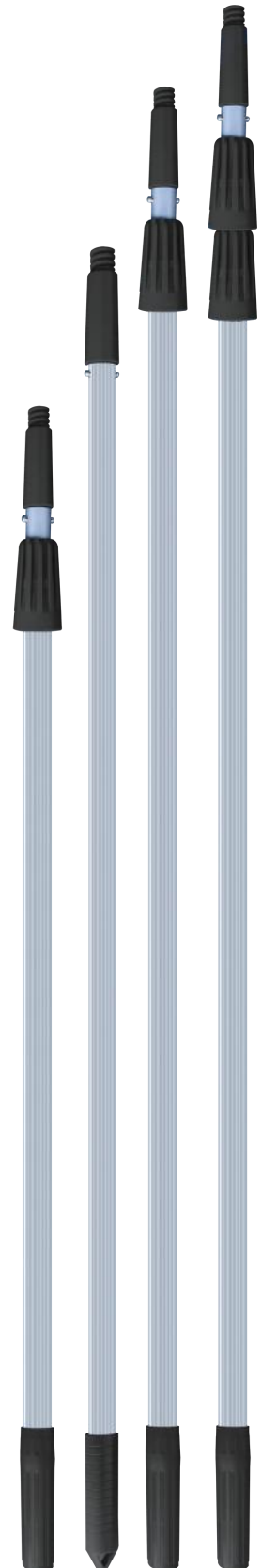

清洁刷 Cleaning Brush

长柄清洁刷 Long Cleaning Brush

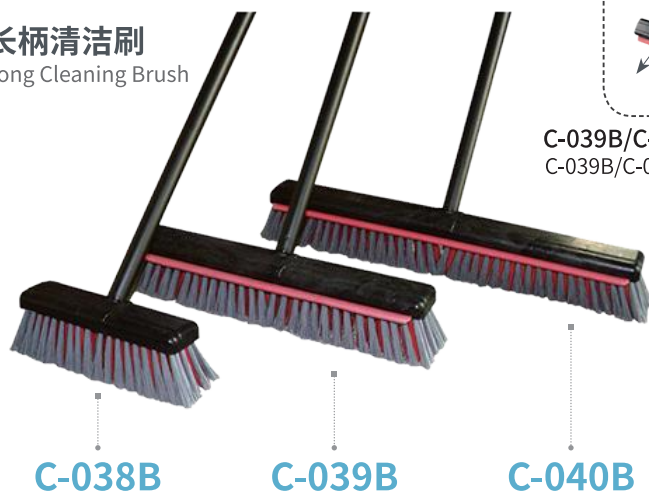

C-039B/C-040B 为带刮胶地板刷
C-039B/C-040B is brush with Stripe



技术参数 Technical Data					
	C-038B	C-039B	C-040B	C-505	C-506
产品特性: Product features:	黑柄, 灰毛刷 Black handgrip, gray brush	黑柄, 灰毛刷 Black handgrip, gray brush	黑柄, 灰毛刷 Black handgrip, gray brush	黑柄, 黄 / 黑刷 Black handgrip, yellow/black brush	黑柄, 红刷 Black handgrip, red brush
包装尺寸 Packing size:	470×290×510mm	520×490×470mm	660×530×470mm	手柄 Handgrip: 1500×175×135mm	1500×175×135mm
刷尺寸 Brush Size:	10" 250mm	18" 450mm	24" 600mm	24" 640×470×435mm	18" 490×470×435mm
包装规格 Packing specification:	20个 / 箱 20pcs/box	20个 / 箱 20pcs/box	20个 / 箱 20pcs/box	20个 / 箱 20pcs/ctn	20个 / 箱 20pcs/ctn

短柄清洁刷 Short Cleaning Brush



长柄清洁刷 Long Cleaning Brush



技术参数 Technical Data				
	C-501	C-502	C-503	C-504
产品特性: Product features:	黑柄, 灰毛刷 Black handgrip, gray brush	黑 / 绿柄, 黄刷 Black/Green handgrip, yellow brush	黑柄, 蓝刷 Black handgrip, blue brush	黑 / 白柄, 黄 / 白刷 Black/White handgrip, yellow/white brush
包装尺寸 Packing size:	620×290×350mm	620×290×350mm	520×270×530mm	520×270×530mm
整箱毛重 Gross weight:	12kg	12kg	13kg	13kg
包装规格 Packing specification:	48个 / 箱 48pcs/box	48个 / 箱 48pcs/box	24个 / 箱 24pcs/box	24个 / 箱 24pcs/box

百洁垫

Floor Pad



C-100B/C-100D

美国 3M 百洁垫
3M Floor Pad



C-101B/C-101D











合资百洁垫
Floor Pad Made In China



C-098

MiNi-18百洁垫
MiNi-18 Floor Pad

合资百洁垫可订做 11",13",15",16",18" 以及蓝色、绿色
Can be made to order 11",13",15",16",18" size or green and blue

技术参数 Technical Data	C-100B	C-100D	C-101B	C-101D	C-098
产品尺寸 Product size:	17"	20"	17"	20"	9"
包装规格 Packing specification:	5片 / 箱 5pcs/box	5片 / 箱 5pcs/box	5片 / 箱 5pcs/box	5片 / 箱 5pcs/box	-
包装尺寸 Packing size:	440×140×440mm	515×140×515mm	440×140×440mm	515×140×515mm	-
整箱毛重 Gross weight:	1.5kg	1.8kg	1kg / 1.1kg / 1.6kg	1.6kg / 1.7kg / 2.3kg	-
颜色 Colour:	   		  	  	



C-099B/C-099D

台湾蝴蝶百洁垫
Floor Pad Taiwan Butterfly

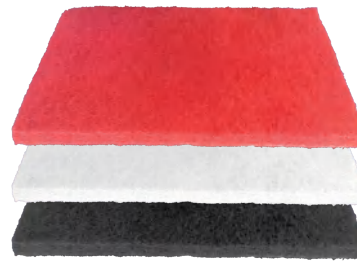

C-097

方块百洁垫
Floor Pad Rectangle

技术参数 Technical Data	C-099B	C-099D	C-097
产品尺寸 Product size:	17"	20"	360×510×25mm
包装规格 Packing specification:	5片 / 箱 5pcs/box	5片 / 箱 5pcs/box	3片 / 箱 3pcs/box
包装尺寸 Packing size:	440×135×440mm	520×135×520mm	512×80×360mm
整箱毛重 Gross weight:	1.18kg / 1.48kg / 1.78kg	1.65kg / 2.1kg / 2.5kg	1.55kg
颜色 Colour:	  	  	  

百洁布

Magic Cloth



C-091B

(美国 3M:9030#)
精细表面无刮伤百洁布
Magic Cloth



C-092B

(美国 3M:6301)
无刮伤海绵百洁布
Magic Sponge Cloth



C-091A

(美国 3M:96#)
高效百洁布
Magic Cloth



C-092A

(美国 3M:7401#)
高效海绵百洁布
Magic Sponge Cloth



C-091C

(美国 3M:9650#)
加厚型高效百洁布
Thick Magic Cloth

技术参数 Technical Data

	C-091B	C-092B	C-091A	C-092A	C-091C
产品尺寸 Product size:	127×89mm	145×75mm	150×100mm	145×75mm	127×89mm
包装规格 Packing specification:	10片 / 盒 10pcs/box 8盒 / 箱 8boxes/case	8片 / 盒 8pcs/box 10盒 / 箱 10boxes/case	5片 / 盒 5pcs/box 20盒 / 箱 20boxes/case	8片 / 盒 8pcs/box 10盒 / 箱 10boxes/case	10片 / 盒 10pcs/box 8盒 / 箱 8boxes/case
包装尺寸 Packing size:	380×250×285mm	765×315×170mm	350×265×280mm	650×320×165mm	380×190×285mm



C-090

腰型百洁布
Magic Cloth



C-091

方型百洁布
Magic Cloth



C-092

起坑海绵百洁布
Magic Sponge Cloth



C-093

腰型海绵百洁布
Magic Sponge Cloth

技术参数 Technical Data

	C-090	C-091	C-092	C-093
产品尺寸 Product size:	115×140×8mm	100×150×8mm	100×70×45mm	82×105×30mm
包装尺寸 Packing size:	230×230×290mm	310×230×210mm	410×240×360mm	320×220×400mm
包装规格 Packing specification:	100片 / 箱 100pcs/box	100片 / 箱 100pcs/box	100片 / 箱 100pcs/box	100片 / 箱 100pcs/box
整箱毛重 Gross weight:	1kg	1.2kg	1.11kg	1kg

喷瓶/清洁小工具

Spray Can / Little Clean Tools

美国高压打气喷瓶
High-pressure spray can



C-081

美国高压打气喷瓶
High-pressure spray can



C-082

美国高压打气喷瓶
High-pressure sparay can



C-083

美国高压打气喷瓶
High-pressure spray can



C-084

塑料小喷瓶
Plastic spray can

技术参数 Technical Data

	C-081	C-082	C-083	C-084
容量 Capacitance:	5L	8L	2L	550mL
包装尺寸 Packing size:	560×380×460mm	565×380×575mm	660×405×335mm	840×430×293mm
包装规格 Packing specification:	6个 / 箱 6pcs/box	6个 / 箱 6pcs/box	15个 / 箱 15pcs/box	60个 / 袋 60pcs/bag
整箱毛重 Gross weight:	10.5kg	11kg	7.1kg	6.8kg



C-041

高级老虎夹
Plastic Fasten Clip
包装 Packing:
25个 / 箱 25pcs/box



C-043

清洁玻璃工具套装
Glass Cleaning Kit
包装 Packing: 1265×265×365mm
5套 / 箱 5pcs/box



C-085

挤水型马桶刷
Toilet Brush
100个 / 袋 100pcs/bag



C-086

浴缸刷
Bathtub Brush
100个 / 袋 100pcs/bag



C-087

圆形尘埃扫
Round Dust Brush



C-087A

杯刷
Cup Brush
100个 / 箱 100bins/box



C-088

腰形管道扫
Waist Pipe Brush



C-089

水池刷
Water Brush
产品尺寸 Size: 90×150×230mm
包装 Packing: 620×320×340mm
100个 / 箱 100pcs/box

清洁配件

Cleaning Accessories



C-042
不锈钢玻璃铲刀
Stainless Steel Glass Knife



C-042A
刀片夹
The Clip Of Knife



C-042B
不锈钢玻璃铲刀 Knife
包装 Packing: 200 片 / 包 200pcs/bag



C-017C
长柄铲刀
Long handle Glass Shovel
包装尺寸 Size: 400×320×190mm
包装 Packing: 50 个 / 箱 50pcs/box



C-017
地板铲刀
Glass Shovel
尺寸 Size: 300×300×250mm
包装 Packing: 50 把 / 箱 50pcs/box



C-017A
地板铲刀片
Glass Shovel
包装 Packing: 100 把 / 包
100bins/bag



C-078/C-079/C-079A
进口双边 / 单边胶条 / 带轮单边胶条
Double/Single Edge Stripe/Wheeled Single
Edge Stripe



C-080
玻璃刮胶条 Glue Stripe
尺寸 Size: 42" 1050mm
包装 Packing: 10 条 / 扎 100pcs/box



C-102
钻石打磨碟
Diamond Mat
产品规格 Product Size:
50#,150#,300#,500#,800#,
1000#,1500#,2000#,3000#
包装 Packing: 6 片 / 盒 6pcs/box



C-103
百亮牌抛光钢丝垫
S.S. Wool
产品规格 Product Size: 0#,1#,2#,3#
包装 Packing: 400×400×620mm
20 片 / 箱 20pcs/box



C-104
百亮牌抛光钢丝球
S.S. Wool
产品规格 Product Size: 0#,1#,2#,3#
包装 Packing: 660×390×390mm
100 个 / 箱 100pcs/box

要选好质量 还是超洁亮

Super Clean Super Qualify

Cleaning
Cart Series

清洁服务车

系列产品



客房服务车

Guest Room Service carts



D-018

标准型客房服务车 (小)
Guest Room Service Cart(Small)



D-017

加高型客房服务车 (大)
Guest Room Service Cart(Large)



D-018A

分隔栏
Compartment Rack



D-018B

标准型客房服务车 (带门)
Guest Room Service Cart(With door)



D-017B

加高型客房服务车 (带门)
Guest Room Service Cart(With door)

技术参数 Technical Data

	D-018	D-018A	D-018B	D-017	D-017B
产品尺寸 Product size:	1480×550×1000mm	638×478×60mm	1480×550×1000mm	1480×550×1200mm	1480×550×1200mm
包装尺寸 Packing size:	1480×556×340mm	650×490×315mm	1480×556×370mm	1480×556×340mm	1480×556×370mm
包装规格 Packing specification:	1台 / 箱 1bins/box	5个 / 箱 5pcs/box	1台 / 箱 1bins/box	1台 / 箱 1bins/box	1台 / 箱 1bins/box
毛重 Gross weight:	37kg	5kg	42.5kg	40kg	47.5kg

客房服务车

Room service cart



D-034

烤漆门盖服务车

baked-paint door-cover service cart



D-035

烤漆弧形服务车

arched baked-paint service cart



D-036

烤漆双边服务车

Double-sided Baking Paint Service Cart



D-037

烤漆双边服务车

Double-sided Baking Paint Service Cart

技术参数 Technical Data

	D-034	D-035	D-036	D-037
产品尺寸 Product size:	1420×460×1150mm	1420×460×1150mm	1420×460×1120mm	1420×460×1120mm
包装尺寸 Packing size:	1460×520×310mm	1460×530×270mm	1460×230×480mm	1460×230×480mm
包装规格 Packing specification:	1台/箱 1bins/box	1台/箱 1bins/box	1台/箱 1bins/box	1台/箱 1bins/box
毛重 Gross weight:	39.4kg	34.6kg	28kg	28kg

布草车

Laundry Cart



D-023
大型圆管布草车
Big Laundry Cart



D-024
中型圆管布草车
Middle Laundry Cart



D-026
长方圆管布草车
Rectangle Laundry Cart



D-027
X型布草车
X Laundry Cart

技术参数 Technical Data

	D-023	D-024	D-026	D-027
产品尺寸 Product size:	980×580×890mm	650×450×830mm	920×560×890mm	680×590×1050mm
包装尺寸 Packing size:	995×595×805mm	670×470×740mm	965×110×630mm	1210×160×640mm
包装规格 Packing specification:	1个 / 箱 1pcs/box	1个 / 箱 1pcs/box	1个 / 箱 1pcs/box	1个 / 箱 1pcs/box
毛重 Gross weight:	16.8kg	12kg	14.96kg	11kg



D-038
布草车(整装)
Linen Cart
(Pre-assembled)



D-039
锥形布草车(不锈钢)
Conical Linen Cart
(Stainless Steel)



D-040
带扶手布草车(整装)
Linen Cart with Armrests
(Pre-assembled)

技术参数 Technical Data

	D-038	D-039	D-040
产品尺寸 Product size:	900×650×800mm	900×650×800mm	1200×640×950mm
包装尺寸 Packing size:	900×650×800mm	900×650×800mm	1200×640×950mm
包装规格 Packing specification:	1个 / 箱 1pcs/box	1个 / 箱 1pcs/box	1个 / 箱 1pcs/box
毛重 Gross weight:	8kg	8kg	8kg



D-041
 手推行李车
 hand-pushed luggage cart



D-042
 客箱包车
 chartered passenger
 compartment vehicle



D-043
 小金顶行李车
 small gold-top luggage cart

技术参数 Technical Data	D-041	D-042	D-043
产品尺寸 Product size:	500×380×1220mm	1050×620×900mm	1070×650×1860mm
包装尺寸 Packing size:	600×500×1250mm	680×230×1110mm	680×520×1520mm
包装规格 Packing specification:	2个 / 箱 2pcs/box	1个 / 箱 1pcs/box	1个 / 箱 1pcs/box
毛重 Gross weight:	26kg	23kg	30kg



D-025A
 大洗衣房车
 Big Laundry Cart



D-025B
 小洗衣房车
 Small Laundry
 Cart



D-028
 大号玻璃钢布草车
 Big Laundry Cart



D-029
 小号玻璃钢布草车
 Small Laundry Cart



D-030
 中号玻璃钢布草车
 Small Laundry Cart

技术参数 Technical Data	D-028	D-029	D-030	D-025A	D-025B
产品尺寸 Product size:	1000×820×840mm	890×690×740mm	1000×800×800mm	1440×780×685mm	1220×760×660mm
包装规格 Packing specification:	1个 / 箱 1pcs/box	1个 / 箱 1pcs/box	1个 / 箱 1pcs/box	1个 / 箱 1pcs/box	1个 / 箱 1pcs/box
容量 Capacity:	410L	280L	350L	350L	250L
毛重 Gross weight:	23kg	18kg	28kg	37kg	31kg
颜色 Colour:					

餐车

Dining Car

技术参数 Technical Data

D-016

产品尺寸 Product size:	800×440×930mm
包装尺寸 Packing size:	780×205×820mm
包装规格 Packing specification:	1个 / 箱 1pcs/box
毛重 Gross weight:	13.7kg

技术参数 Technical Data

D-016B

产品尺寸 Product size:	800×440×930mm
包装尺寸 Packing size:	780×205×820mm
包装规格 Packing specification:	1个 / 箱 1pcs/box
毛重 Gross weight:	14.5kg



D-016

B型餐盘收集车
Dinner Collector Cart B

D-016B

新型餐盘收集车
Dinner Collector Cart



D-014A

不锈钢三层餐车
Three-tier Stainless
Steel Dining Car

技术参数 Technical Data

D-014A	产品尺寸 Product size	包装尺寸 Packing size
大 Big	930×500×950mm	920×520×150mm
中 Middle	850×450×890mm	820×470×150mm
小 Small	750×400×830mm	720×420×150mm

技术参数 Technical Data

D-014B	产品尺寸 Product size	包装尺寸 Packing size
大 Big	950×500×930mm	950×520×140mm
中 Middle	850×450×890mm	850×470×140mm
小 Small	750×400×820mm	750×420×140mm

技术参数 Technical Data

D-014C	产品尺寸 Product size	包装尺寸 Packing size
大 Big	950×500×940mm	960×520×145mm
中 Middle	850×450×890mm	860×470×145mm
小 Small	750×400×820mm	760×420×145mm



D-014B

不锈钢收碗车
Stainless Steel Bowl Car

D-014C

不锈钢酒水车
Stainless Steel Drink Car

多用途手推车

Garbage Collection Tools

技术参数 Technical Data

D-011	
包装尺寸 Product size:	880×260×545mm
产品尺寸 Packing size:	1140×510×980mm
包装规格 Packingspecification:	1台 / 箱 1bins/box
毛重 Gross weight:	14kg
颜色 Colour:	



D-011
多用途清洁手推车
Janitor Cart

技术参数 Technical Data

D-011-1	
包装尺寸 Product size:	880×260×545mm
产品尺寸 Packing size:	1140×510×980mm
包装规格 Packingspecification:	1台 / 箱 1bins/box
毛重 Gross weight:	14.45kg
颜色 Colour:	



D-011-1
多用途带盖清洁手推车
Janitor Cart (With cover)

可替换铁轮
iron wheels optional



手推车使用示意图
The Using Of Janitor Cart

技术参数 Technical Data

D-012	
包装尺寸 Product size:	945×515×270mm
产品尺寸 Packing size:	1020×500×950mm
包装规格 Packingspecification:	1个 / 箱 1pcs/box
毛重 Gross weight:	17kg
净重 Net weight:	14kg
颜色 Colour:	



D-012
大号多用途三层手推车 (不带桶)
Large Dinner Trolley(Without Bucket)



D-012A
大号多用途三层手推车 (带桶)
Large Dinner Trolley(With Bucket)

技术参数 Technical Data

D-012A	
包装尺寸 Product size:	945×515×270mm
产品尺寸 Packing size:	1300×500×950mm
包装规格 Packingspecification:	1个 / 箱 1pcs/box
毛重 Gross weight:	17kg
颜色 Colour:	

要选好质量 还是超洁亮
Super Clean Super Qualify

Hotel
Supplies Series
酒店用品
系列产品



雨伞机/架

Umbrella Holder/Stand

技术参数 Technical Data

D-001

产品尺寸 Product size:	500×330×890mm
包装尺寸 Packing size:	580×385×945mm
包装规格 Packingspecification:	1台 / 箱 1bins/box
毛重 Gross weight:	24kg



D-001
双头伞袋机
Umbrella Holder

技术参数 Technical Data

D-002

产品尺寸 Product size:	1100×450×900mm
包装尺寸 Packing size:	1065×450×120mm
包装规格 Packingspecification:	1台 / 箱 1bins/box
毛重 Gross weight:	



D-002
36头带锁豪华型雨伞架
36 Pcs Umbrella Stand



D-003
24头带锁豪华型雨伞架
24 Pcs Umbrella Stand



D-004
18头带锁豪华型雨伞架
18 Pcs Umbrella Stand



D-005
12头带锁豪华型雨伞架
12 Pcs Umbrella Stand

技术参数 Technical Data

	D-003	D-004	D-005
产品尺寸 Product size:	1100×450×900mm	600×450×900mm	600×300×900mm
包装尺寸 Packing size:	1065×450×120mm	820×470×105mm	820×330×105mm
包装规格 Packingspecification:	1台 / 箱 1bins/box	1台 / 箱 1bins/box	1台 / 箱 1bins/box
毛重 Gross weight:		8.15kg	5.4kg

皂液容器

Soap Dispenser

技术参数 Technical Data

	D-055A	D-325
容量 Capacity:	600mL	700mL
包装尺寸 Packing size:	620×440×350mm	430×410×400mm
包装规格 Packing specification:	24 台 / 箱 24bins/box	24 台 / 箱 24bins/box
整箱毛重 Gross weight:	14.4kg	12.6kg



D-055A

感应式皂液机
Sensitive Soap Dispenser



D-325

感应式皂液机
Sensitive Soap Dispenser



D-723

自动皂液器
Auto Soap Dispenser



D-722

自动皂液器
Auto Soap Dispenser

技术参数 Technical Data

	D-723	D-722
额定电压 Rated voltage:	DC 4×1.5V(LR6)	DC 6V(12W)
容量 Capacity:	800mL	2100mL
每次液量 / 喷雾 Every drop/atomizing:	1mL	0.5-0.6mL
包装尺寸 Packing size:	540×272×367mm	425×400×347mm
配用直流变压器输入电压 Input voltage:	--	220V/50Hz
包装规格 Packing specification:	16 个 / 箱 16pcs/box	6 个 / 箱 6pcs/box
整箱毛重 Gross weight:	16kg	11kg

技术参数 Technical Data

	D-051	D-052
容量 Capacity:	500mL	400mL
包装尺寸 Packing size:	90×210×70mm	165×80×50mm
包装规格 Packing specification:	495×310×465mm	445×265×375mm
整箱毛重 Gross weight:	30 个 / 箱 30pcs/box	30 个 / 箱 30pcs/box
	17kg	15kg



D-051

不锈钢皂液器 (单头)
Stainless steel soap dispenser(Single head)



D-052

手动皂液器
Single Head Steel Soap Dispenser



D-725

双头金属皂液器
Double Head Steel Soap Dispenser



D-726

不锈钢皂液器 (双头)
Stainless steel soap dispenser(Double Head)

技术参数 Technical Data

	D-725	D-726
容量 Capacity:	1000mL	800mL
包装尺寸 Packing size:	165×195×80mm	165×150×52mm
包装规格 Packing specification:	555×360×415mm	525×325×375mm
整箱毛重 Gross weight:	20 个 / 箱 20pcs/box	24 台 / 箱 24pcs/box
	21kg	19.8kg

手动皂液容器

Soap Dispenser



D-708D

手动皂液器

Touch Soap Dispenser



D-708

手动皂液器

Touch Soap Dispenser



D-709A

手动皂液器

Touch Soap Dispenser



D-709B

手动皂液器

Touch Soap Dispenser

技术参数 Technical Data

	D-708D	D-708	D-709A	D-709B
容量 Capacity:	350mL	350mL × 2	300mL	300mL × 2
产品尺寸 Product size:	66×78×195 mm	134×78×195 mm	71×80×177 mm	143×80×177 mm
净重 Net weight:	25 KG	25 KG	29.2 KG	28.75 KG
整箱毛重 Gross weight:	26.14 KG	26.14 KG	30.8 KG	30.8 KG
包装尺寸 Packing size:	725×435×420 mm	725×435×420 mm	770×448×388 mm	770×448×388 mm
包装规格 Packing specification:	100 个 / 箱 100pcs/box	50 个 / 箱 50pcs/box	100 个 / 箱 20pcs/box	50 个 / 箱 50pcs/box



D-706A

手动皂液器

Touch Soap Dispenser



D-707A

手动皂液器

Touch Soap Dispenser



D-707B

手动皂液器

Touch Soap Dispenser

技术参数 Technical Data

	D-706A	D-707A	D-707B
容量 Capacity:	300mL × 2	300mL	300mL × 2
产品尺寸 Product size:	126×73×187mm	71×80×177 mm	143×80×177 mm
净重 Net weight:	20.6 KG	29.2 KG	28.75 KG
整箱毛重 Gross weight:	22.6 KG	30.8 KG	30.8 KG
包装尺寸 Packing size:	690×395×400 mm	770×448×388 mm	770×448×388 mm
包装规格 Packing specification:	50 个 / 箱 50pcs/box	100 个 / 箱 100pcs/box	50 个 / 箱 50pcs/box

手动皂液容器

Soap Dispenser



D-719B

手动皂液器
Touch Soap Dispenser

D-719A

手动皂液器
Touch Soap Dispenser

技术参数 Technical Data

	D-719A	D-719B
容量 Capacity:	380mL	380mL×2
每次滴液 Every Drop:	1mL	1mL
包装尺寸 Packing size:	515×278×422mm	415×349×420mm
包装规格 Packing specification:	30个 / 箱 30pcs/box	16个 / 箱 16pcs/box
整箱毛重 Gross weight:	9.5kg	10kg

手动皂液容器

Soap Dispenser



D-053A
手动皂液器
Soap Dispenser



D-053B
手动皂液器
Soap Dispenser



D-312A
手动皂液机
Soap Dispenser

单头
Single Head

技术参数 Technical Data

	D-053A	D-053B	D-312A
容量 Capacity	400mL	500mL	350mL
产品尺寸 Product size:	80×75×150mm	80×75×150mm	88×85×165mm
包装尺寸 Packing size:	455×425×400mm	520×395×418mm	495×495×364mm
包装规格 Packing specification:	50 个 / 箱 50pcs/box	50 个 / 箱 50pcs/box	50 个 / 箱 50pcs/box
整箱毛重 Gross weight:	12.7kg	16.7kg	14.1kg



D-053A
手动皂液器
Soap Dispenser



D-053B
手动皂液器
Soap Dispenser



D-312B
手动皂液机
Soap Dispenser

双头
Double Head

技术参数 Technical Data

	D-053A	D-053B	D-312B
容量 Capacity	800mL	1000mL	700mL
产品尺寸 Product size:	165×75×150mm	165×75×150mm	180×85×165mm
包装尺寸 Packing size:	547×340×400mm	520×468×418mm	573×400×539mm
包装规格 Packing specification:	24 个 / 箱 24pcs/box	30 个 / 箱 30pcs/box	36 个 / 箱 36pcs/box
整箱毛重 Gross weight:	11.6kg	18.7kg	19.2kg

擦手纸箱

Paper Dispenser



D-095

擦手纸箱

Paper Dispenser



D-096

擦手纸箱

Paper Dispenser



D-099

擦手纸箱

Paper Dispenser



D-100

擦手纸箱

Paper Dispenser



D-101

擦手纸箱

Paper Dispenser

技术参数 Technical Data

	D-095	D-096	D-099	D-100	D-101
产品尺寸 Product size:	270×104×205mm	270×104×205mm	270×110×200mm	270×110×200mm	261×114×213 mm
包装尺寸 Packing size:	575×575×450mm	575×575×450mm	590×550×460mm	590×550×460mm	605×550×465 mm
包装规格 Packing specification:	20 个 / 箱 20pcs/box	20 个 / 箱 20pcs/box	20 个 / 箱 20pcs/box	20 个 / 箱 20pcs/box	20 个 / 箱 20pcs/box
整箱毛重 Gross weight:	12kg	12kg	10.6kg	10.6kg	16.1 kg



D-084/D-085

不锈钢擦手纸箱

Paper Dispenser



D-097

擦手纸箱

Paper Dispenser



D-098

擦手纸箱

Paper Dispenser



D-083

不锈钢擦手纸盒

Paper Dispenser

技术参数 Technical Data

	D-084(大 Large)	D-085(小 Small)	D-097	D-098	D-083
产品尺寸 Product size:	290×100×390mm	290×100×290mm	270×110×330mm	270×110×330mm	135×119×85mm
包装尺寸 Packing size:	570×385×600mm	570×300×560mm	570×355×695mm	570×355×695mm	475×260×380mm
包装规格 Packing specification:	10 台 / 箱 10pcs/box	10 台 / 箱 10pcs/box	12 个 / 箱 12pcs/box	12 个 / 箱 12pcs/box	10 个 / 箱 10pcs/box
整箱毛重 Gross weight:	18kg	17kg	12kg	12kg	11kg

圆形纸箱

Circular Paper Dispenser



D-087
大卷纸箱
Paper Dispenser



D-086
大卷纸箱
Paper Dispenser



D-727
大卷纸箱
Paper Dispenser



D-728
大卷纸箱
Paper Dispenser

技术参数 Technical Data

	D-086/D-087	D-727	D-728
产品尺寸 Product size:	268×127×280mm	254×118×262mm	250×125×260mm
包装尺寸 Packing size:	575×425×590mm	670×540×290mm	645×550×580mm
包装规格 Packing specification:	12台 / 箱 12pcs/box	10台 / 箱 10pcs/box	20台 / 箱 20pcs/box
整箱毛重 Gross weight:	10.6kg	14kg	19kg

大卷纸箱

Paper Dispenser



D-081
大卷纸箱
Paper Dispenser



D-082
大卷纸箱
Paper Dispenser



D-089
大卷纸箱
Paper Dispenser

技术参数 Technical Data

	D-089	D-081	D-082
产品尺寸 Product size:	ø260×120mm	270×131mm	270×130mm
包装尺寸 Packing size:	660×275×560mm	575×420×596mm	575×420×595mm
包装规格 Packing specification:	10台 / 箱 10pcs/box	12台 / 箱 12pcs/box	12台 / 箱 12pcs/box
整箱毛重 Gross weight:	17kg	10kg	10kg

干手机

Hand-dryer



D-064
干手机
Hand-dry



D-065
干手机
Hand-dry



D-067
干手机
Hand-dry

技术参数 Technical Data

	D-064	D-065	D-067
产品尺寸 Product size:	1800W	1600W	1000W
包装尺寸 Packing size:	600×300×470mm	500×330×445mm	715×337×400mm
包装规格 Packing specification:	4台 / 箱 4pcs/box	4台 / 箱 4pcs/box	6台 / 箱 6pcs/box
整箱毛重 Gross weight:	16.5kg	16kg	12.5kg



D-716
干手器
Hand-dry



D-717
干手器
Hand-dry



D-718
喷射式干手器
Jet Hand-dry

技术参数 Technical Data

	D-716	D-717
额定电压 Rated voltage:	250V/50Hz	250V/50Hz
额定功率 Rated power:	2500W	2500W
防水等级 Water proofing grade:	1PX1	1PX1
风速 Wind speed:	30m/S	30m/S
额定电流 Rated current:	11.3A	11.3A
风量 Air volume:	270m ³ /h	270m ³ /h
包装尺寸 Packing size:	560×328×485	574×325×385
包装规格 Packing specification:	4个 / 箱 4pcs/box	4个 / 箱 4pcs/box
毛重 Gross weight:	26.5kg	23.5kg

技术参数 Technical Data

	D-718
额定电压 Rated voltage:	DC 6V
额定功率 Rated power:	1400W
防水等级 Water proofing grade:	1P22
每次喷雾 Every atomizing:	0.5-0.6ml
配用直流变压器输入电压 Input voltage:	220V/50Hz
包装尺寸 Packing size:	735×371×330mm
包装规格 Packing specification:	1个 / 箱 1pcs/box
毛重 Gross weight:	10kg

自动喷香机

Automatic Perfume Dispenser



D-070C

自动喷香机

Perfume Dispenser



D-328

自动喷香机

Perfume Dispenser



D-721

自动喷香机

Perfume Dispenser



D-724

自动喷香机

Perfume Dispenser



D-729

自动喷香机

Perfume Dispenser



D-730

自动喷香机

Perfume Dispenser

技术参数 Technical Data

	D-070C	D-328	D-721	D-724	D-729	D-730
产品尺寸 Producing size:	85×90×240mm	80×80×210mm			86×83×236mm	95×90×225mm
包装尺寸 Packing size:	480×300×515mm	480×300×515mm	510×295×445mm	495×275×530mm	480×470×510mm	520×490×490mm
包装规格 Packing specification:	30 台 / 箱 30pcs/box	30 台 / 箱 30pcs/box	24 / 箱 24pcs/box	30 / 箱 30pcs/box	50 / 箱 50pcs/box	50 / 箱 50pcs/box
毛重 Gross Weight:			14kg	18kg	25kg	18kg

干发机

Hair-dryer



D-061B

700B 干发器

Hair-dryer



D-068

美发器

Hair-dryer

技术参数 Technical Data

	D-061B	D-068
功率 Power:	700W	1200W
包装规格 Packing specification:	8 个 / 箱 8pcs/box	12 个 / 箱 12pcs/box
包装尺寸 Packing size:	500×440×420mm	582×225×412mm
整箱毛重 Gross weight:	22kg	18.5kg

酒店用品

Hotel Supplies



黑白根玻璃盘
Black and White
Root Glass Plate



玫瑰金不锈钢盘
Rose Gold Stainless
Steel Plate



钛金不锈钢盘
Titanium Gold
Stainless Steel Plate



不锈钢盘
Stainless Steel Plate



紫罗兰盘
Violet Plate



D-044 新概念烟灰桶
New Concept Ash Bin



玫瑰金
rose gold



钛金
titanium gold



砂钢
brushed steel

技术参数 Technical Data

D-044

产品尺寸 Product size:	240×280×740mm
包装尺寸 Packing size:	340×320×680mm
包装规格 Packing specification:	1个 / 箱 1pcs/box
毛重 Gross weight:	8k



D-045 新概念烟灰桶
New Concept Ash Bin



玫瑰金
rose gold



钛金
titanium gold



砂钢
brushed steel

技术参数 Technical Data

D-045

产品尺寸 Product size:	330×300×860mm
包装尺寸 Packing size:	350×330×820mm
包装规格 Packing specification:	1个 / 箱 1pcs/box
毛重 Gross weight:	9k

酒店用品

Hotel Supplies



D-032





方形丽格座地烟灰桶
Ground Ash Barrel



D-033

圆网格、菊形果皮箱
Dustbin

技术参数 Technical Data





	D-032	D-033
产品尺寸 Producing size:	255×255×635mm	255×255×630mm
包装尺寸 Packing size:	515×515×635mm	520×520×630mm
包装规格 Packing specification:	4个 / 箱 4pcs/box	4个 / 箱 4pcs/box
整箱毛重 Gross weight:	30kg	14.5kg
颜色 Colour:	 	 



D-105

防尘垫
Floor Mat In Roll

技术参数 Technical Data

	D-105	
材料 Material:	3M6050 料	8A 料
产品尺寸 Producing size:	1.2×24m	1.2×18m
包装规格 Packing specification:	 	 
整箱毛重 Gross weight:	67.68kg	70kg



D-008

A 型豪华弹簧垫折叠加床
A Extra Bed



D-010

C 型豪华海绵压板折叠加床
C Extra Bed



D-010B

豪华海绵压板折叠加床
Extra Bed

技术参数 Technical Data

	D-008	D-010	D-010B
产品尺寸 Producing size:	1950×900×500mm	1930×900×440mm	1930×740×470mm
包装尺寸 Packing size:	950×585×1110mm	950×310×1070mm	780×200×1090mm
包装规格 Packing specification:	1个 / 箱 1pcs/box	1个 / 箱 1pcs/box	1个 / 箱 1pcs/box
床垫厚度 Mattress thickness:	180mm	90mm	60mm
毛重 Gross weight:	48kg	25kg	19.2kg

酒店用品

Hotel Supplies



D-071A
矮身空气清新剂
Short Bottle Air-
refreshing

技术参数 Technical Data

D-071A

容量 Capacitance:	300mL
包装规格 Packing specification:	10 支 / 箱 10pcs/box
气味 Scent:	古龙 / 沙丘 / 柠檬 / 茉莉 Cologne/Sand dunes/Lemon/Jasmine scent

技术参数 Technical Data

D-171G

包装规格 Packing specification:	120 个 / 箱 120pcs/box
-----------------------------	----------------------



D-171G
香精块
Urinal Deodorizer



D-171H
香精球
Urinal Deodorizer

技术参数 Technical Data

D-171H

包装尺寸 Packing size:	380×240×300mm
包装规格 Packing specification:	5 粒 / 包 72 包 / 箱 5grain/bag 72bags/box
整箱毛重 Gross weight:	13.5kg



D-720
自动出纸器
Auto Output Tray

技术参数 Technical Data

D-720

使用电源 Power supply:	DC 1.5V×4 R20S
卷纸尺寸 Size of toilet roll:	Φ 直径 ≤ 200mm
宽度 Width:	195-200mm
包装尺寸 Packing size:	445×345×290
包装规格 Packing specification:	1 个 / 箱 1pcs/box
毛重 Gross weight:	3.5kg

酒店清洁剂

The Hotel Cleaner



KB-3
石材晶硬保养剂
Crystallizing
Pink StaeFor

KB-2
花岗石晶硬剂
大理石晶硬剂
Granite Crystallizing
Marble Crystallizing



D-131
西班牙进口 K2
Spain Granite Crystallizing



D-132
西班牙进口 K3
Spain Granite Crystallizing

技术参数 Technical Data

	D-131	KB-2	KB-3
容量 Capacitance:	6kg	5kg	5kg
包装规格 Packing specification:	3 罐 / 箱 3bins/box	3 罐 / 箱 3bins/box	3 罐 / 箱 3bins/box



DFH017
84消毒液



SC128
超洁亮 128
万能起渍剂
SUPER CLEAN 128
Spot Remover



AS-116A
KIMBO
香口胶溶剂
KIMBO Chewing
Gum Solvent



D-133B
洁而亮
KIP Cleaner



D-122B
凯鹏
FURNITURE POLISH



D-119
KIMBO 擦铜水
KIMBO Pledge Cleanser

技术参数 Technical Data

	DFH017	SC128	AS-116A	D-133B	D-122B	D-119
容量 Capacitance:	750mL	700mL	300mL	500mL	350mL	400mL
包装规格 Packing specification:	24支 / 箱 24pcs/box	12 支 / 箱 12pcs/box	15 支 / 箱 15pcs/box	16 支 / 箱 16pcs/box	12 支 / 箱 12pcs/box	12 支 / 箱 12pcs/box

保温箱系列

Thermal insulation box series



E-25

冰大师保温箱
ICEMASTER PRO



E-50

冰大师保温箱
ICEMASTER PRO



E-70

冰大师保温箱
ICEMASTER PRO



E-120

冰大师保温箱
ICEMASTER PRO

技术参数 Technical Data

	E-25	E-50	E-70	E-120
材质 Material:	HDPE&PP	HDPE&PP	HDPE&PP	HDPE&PP
容量 Capacitance:	25L	50L	70L	120L
净重 Net Weight:	4.63KG	6KG	9.74KG	14.15KG
毛重 Gross Weight:	6.2KG	7.42KG	11.32KG	16.41KG
内尺寸 inner dimension:	298×230×375mm	595×295×269mm	649×330×316mm	778×395×378mm
外型尺寸 Dimensions:	370×320×520mm	707×383×372mm	756×454×416mm	900×523×497mm
包装规格 Packing specification:	390×360×560mm	735×416×430mm	795×465×495mm	932×547×567mm



E-30

冰大师保温箱®
ICEMASTER®



E-65

冰大师保温箱®
ICEMASTER®



E-85

冰大师保温箱®
ICEMASTER®

技术参数 Technical Data

	E-30	E-65	E-85
材质 Material:	HDPE&PP	HDPE&PP	HDPE&PP
容量 Capacitance:	30L	65L	85L
净重 Net Weight:	3.412KG	7.4KG	7.5KG
毛重 Gross Weight:	6.37KG	8.3KG	8.5KG
内尺寸 inner dimension:	416×296×238mm	550×400×270mm	560×450×300mm
外型尺寸 Dimensions:	510×385×305mm	650×500×370mm	640×530×400mm
包装规格 Packing specification:	580×450×369mm	710×575×432mm	703×593×470mm

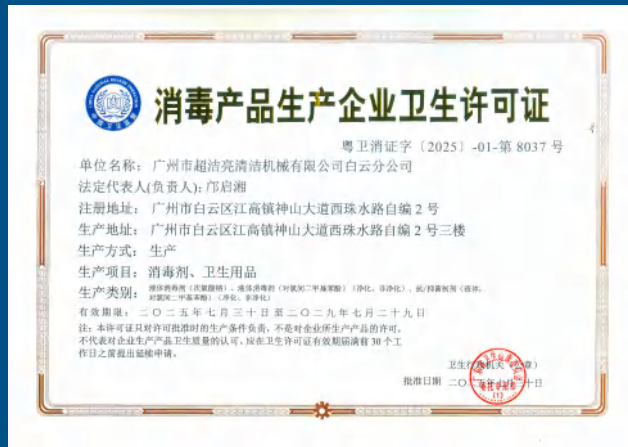

超洁亮获得“消毒产品生产企业卫生许可证”

粤卫消证字 [2025] -01-第8037号

3 大品牌、5 款消毒功能
清洁剂火热供应中

DFF014 中性消毒剂 (绿水)
DFF027 浴室消毒剂
DFG015 消毒剂 (可高倍稀释)
DFH012 抗菌洗手液
DFH017 84 消毒液



要选好质量 还是超洁亮

Super Clean Super Qualify

General
Detergent Series
清洁剂品牌
系列产品



深海洁系列



KIMBO 系列



SUPER·CLEAN

SUPER CLEAN 系列



驰丽洁
驰丽洁系列



更多详情请访问超洁亮官方网站：www.super-clean.com.cn

DFF001 特光超级蜡水 (免抛蜡)

HIGH SPEED FLOOR FINISH



SUPER CLEAN 品牌
Super-clean Brand



KIMBO 品牌
KIMBO Brand



深海洁品牌
Sea Clean Brand



驰丽洁品牌
ChiLiJie Brand

包装容量 Packing Capacition:3.8L/19L

用途特点: 本品为乳白色, 略带氨味。固体含量高, 快干、抗尘、抗滑、不会变黄, 亮度持久, 能清除鞋跟痕迹。适用于胶地板、花岗石、云石地板等。经高速磨光后, 蜡面更光、更硬、更耐磨。

成分特性: 金属交联聚合物。乳白色、略带氨味。

用法用量: 无须稀释, 直接使用干净蜡拖或涂水器均匀涂布, 上蜡前应用起蜡水除去旧蜡层及用清水或中性绿水彻底清洁地面并风干。可视需要涂布多层, 待前一层蜡面干透再涂布第二层。

注意事项: 所用清洁剂应不含肥皂、氨水、强碱和丁基溶剂特质。避免触及眼睛, 若已接触, 立即用大量清水冲洗。切勿入口。使用时建议戴上防护手套。

Use features: This product is milky white and shows a slight smell of ammonia. It is characterized by high solid content, quick drying, anti dust, anti slide and lasting brightness. Meanwhile, it won't become yellow and it enables to clean the traces of shoe heel. It is suitable for rubber floor, granite and marble floor etc. After high speed polishing, wax surface is smoother, harder and more wear-resistant.

Ingredient characteristics: Metal crosslinked polymer. Milky white, slightly ammonia.

Usage and dosage: Without dilution, a clean wax mop or a water scrape is directly used to evenly spread the product. Before waxing, use the stripper to remove the old wax layer, clear water or mild all purpose cleaner to thoroughly clean the ground and dry it. More layers can be coated if required. The second layer wax can be coated after the first wax surface dries.

Note: All detergents shall not contain soap, alkali, ammonia and butyl solvent characteristics. Avoid touching the eyes. In case of contact, rinse immediately with plenty of water. Never eating. It is suggested to wear protective gloves when using.

DFF002 高速面蜡

FLOOR FINISH



SUPER CLEAN 品牌
Super-clean Brand



KIMBO 品牌
KIMBO Brand



深海洁品牌
Sea Clean Brand



驰丽洁品牌
ChiLiJie Brand

包装容量 Packing Capacition:3.8L/19L

用途特点: 本品是一种高档地板上光剂, 适用于高速抛光机磨光。抛光性能好, 亮度高, 不易发黄。日常维护方便。适用于胶地板、花岗石、云石地板等, 形成镜亮表面, 特别持久耐用, 能防止洗涤剂、划痕、滑擦、鞋跟磨擦等伤害。

成分特性: 金属交联聚合物。乳白色、略带氨味。

用法用量:

1. 除去地板旧蜡, 清水洗净并至干燥 (如有必要可以先涂 1-2 层底蜡)。
2. 用清洗拖布或涂蜡机均匀薄层涂布本品, 涂布后干燥 30 分钟以上, 可逐层涂布, 但 24 小时内不能超过 4 次。
3. 平时每天用拖布除去表面污物。如需去除油污痕迹, 可用绿水或中性全能清洗剂稀释后拖布沾湿拖擦。
4. 为恢复蜡面原有光亮度, 先喷洒水后再抛光 (可用高速抛光机抛光)。

注意事项: 所用清洁剂应不含肥皂、氨水、强碱和丁基溶剂特质。避免触及眼睛, 若已接触, 立即用大量清水冲洗。切勿入口。使用时建议戴上防护手套。

Use features: This product is a high-grade floor finish agent and it is suitable for finishing by a high-speed polisher. It is characterized by good polishing performance and high brightness. It is not easy to become yellow and its daily maintenance is convenient. It is suitable for rubber floor, granite and marble floor etc. After using, the floor can form a mirror-glass surface, especially, it is durable. Additionally, it can prevent the damages from detergent, scratches, sliding eraser and shoe heel friction.

Ingredient characteristics: Metal crosslinked polymer. Milky white, slightly ammonia.

Usage and dosage:

1. Remove the old wax on the floor and use clearwater to clean and drying (if necessary, the first 1-2 layer of wax shall be coated).
2. Use a clean mop or a wax spreader to evenly spread the product. After spreading, dry it for more than 30 minutes. Although it can be spread layer by layer, it can't exceed 4 times within 24 hours.
3. Remove the surface dirt with a mop each day. If you need to remove traces of oil, it can be diluted with all purpose cleaner or multi-purpose mild cleaning agent and the mop gets wet with the product to wipe.
4. In order to recover the original light brightness of the wax surface, spray this product first and then polish it (it can be polished by the high speed polisher).

Note: All detergents shall not contain soap, alkali, ammonia and butyl solvent characteristics. Avoid touching the eyes. In case of contact, rinse immediately with plenty of water. Never eating. It is suggested to wear protective gloves when using.

DFF003

清洁磨光蜡

HIGH CLEAN FLOOR POLISH



SUPER CLEAN 品牌
Super-clean Brand



KIMBO 品牌
KIMBO Brand



深海洁品牌
Sea Clean Brand



驰丽洁品牌
ChiLiJie Brand

包装容量 Packing Capacition:3.8L/19L

用途特点: 本品为乳白色,清香的清洁磨光蜡。特别适用于物业管理单位使用。适用于已上蜡地面保养时做修补上蜡用,清洁修补一次完成。

成分特性: 金属交联聚合物、乳化石蜡。乳白色、清香。

用法用量:

1. 日常保养时用清洁剂处理过的拖布除尘。有油污时可用拖布沾稀释的中性全能清洁剂擦清洁。对污垢较多处,全能清洁剂浓度可稍大些。
2. 再用喷壶将清洁磨光蜡喷洒在地面上,用抛光机高速抛光即可。

注意事项: 所用清洁剂应不含肥皂、氨水、强碱和丁基溶剂特质。

Use features: This product is a high gloss floor finish characterized by milky white and delicate fragrance.Especially suitable for the use of the property management unit. Furthermore, it is suitable for supplementing wax,cleaning and repairing in case of maintenance of the waxed surface,

Ingredient characteristics:Metal cross-linked polymer, emulsion paraffin. Milky white and delicate fragrance.

Usage and dosage:1.Of daily maintenance, use the mop soaked with detergent to remove dust. In case of the oil, use the mop soaked with the diluted mild detergent to wipe. As for the place with much dirt, the concentration of the detergent is thicker. 2.Use a spray can to spray the clean polish wax on the floor and then polish with a high speed polisher.

Note: The used detergent shall not contain soap,alkali,ammonia and butyl solvent characteristics.

DFF004

封地底蜡

ACRYLIC SEALER



SUPER CLEAN 品牌
Super-clean Brand



KIMBO 品牌
KIMBO Brand



深海洁品牌
Sea Clean Brand



驰丽洁品牌
ChiLiJie Brand

包装容量 Packing Capacition:3.8L/19L

用途特点: 本品是一种乳白色,略带氨味的,水乳型地板底层涂蜡。具有坚硬、透明、光亮的特性。它能防止水份、油污等渗入地板。适合于纸皮石、花岗岩、塑胶、云石等材质地板。

成分特性: 金属交联聚合物。乳白色、略带氨味。

用法用量:

1. 清洁地面: 扫净地面, 除去粘附物, 铲除旧蜡, 清水洗净并干燥。
2. 涂底蜡: 用清洁线绳拖布或涂蜡机涂布, 均匀涂上薄层底蜡, 30 分钟后干燥。对多孔地面可施予较厚涂层, 浸渍 5 分钟, 在干燥前将多余的蜡液擦去。为改善表面效果, 可在第一层凝固后涂布第二层。
3. 涂布蜡面: 按面蜡使用说明涂布。

注意事项: 所用清洁剂应不含肥皂、氨水、强碱和丁基溶剂特质。

Use features: This product is a milky white and water-emulsion floor prime wax with slightly ammonia smell.It presents hard,transparent,bright characteristics. It can prevent water and oil stain into the floor.It is suitable for ceramic tiles,granite,plastic cement,marble and othe floor materials etc.

Ingredient characteristics:Metal crosslinked polymer. Milky white and slightly ammonia smell.

Use and dosage:

- 1.Clean ground:sweep the ground, remove the adhesion and old wax and use clear water to clean and dry.
- 2.Coat prime wax:use the clear mop string to tie the mop or the wax sprayer to spread the thin prime wax. Dry it after 30 minutes. Thicker coating shall be spread on the porous surface and then immersed for 5 minutes. Remove the excessive liquid wax before dry. In order to improve the surface effect,the second layer can be spread after the first layer is solidified.
- 3.Spreading wax surface:spread it in accordance with the use instructions of surface wax.

Note: The detergent shall not contain soap,alkali,ammonia and butyl solvent characteristics.

DFF005

柠檬家私蜡

LEMON FURNITURE WAX



SUPER CLEAN 品牌
Super-clean Brand



KIMBO 品牌
KIMBO Brand



深海洁品牌
Sea Clean Brand



驰丽洁品牌
ChiLiJie Brand

包装容量 Packing Capacition:3.8L/19L

用途特点: 本品为乳白色,有特檬香味。是浓缩型家俱清漆上光乳剂。清洁、上光、保护,一次完成。本品广泛应用于木制品、高档家俱、台桌柜、塑料容器、搪瓷、陶瓷、胶木、皮革、乙烯塑料、瓷砖、电气仪表、文件柜、金属物品、音响、电视机柜、自动售货机、办公用品以及其它要求清洁光亮表面的各种物品清洁保养。

成分特性: 乳化异链烷烃、二甲硅氧烷。乳白色、柠檬香。

用法用量: 在物品表面喷上少许本品,然后用干布擦亮。或在干抹布上倒入少许本品,抹擦物品表面,再用干布擦亮。

注意事项: 使用时硬表面尽量保持干爽。

Use features: This product is milky white, with lemon fragrance. It is a concentrated-type furniture polish emulsion. Cleaning, polishing and protection are completed once. The product is widely used for clean and maintenance of woodware, high-grade furniture, table cabinet, plastic container, enamel, ceramics, bakelite, leather, vinyl plastic, ceramic tile, electrical instrument, filing cabinet, metal goods, audio, TV cabinet, vending machine, office equipment and other articles that are required to have a clean and bright surface.

Ingredient characteristics: Emulsified ISO paraffin and di-methyl silicone. Milky white and lemon fragrance.

Usage and dosage: A little amount of this product is sprayed on the surface of the article and then polished with a dry cloth. A little amount of this product is poured on the dry cloth to wipe the surface of the article and then polish by the dry cloth.

Note: Try the best to keep the hard surface dry when using.

DFF006

除油剂

DEGREASER



SUPER CLEAN 品牌
Super-clean Brand



KIMBO 品牌
KIMBO Brand



深海洁品牌
Sea Clean Brand



驰丽洁品牌
ChiLiJie Brand

包装容量 Packing Capacition:3.8L/19L

用途特点: 本品是一种多功能的除油剂,适用于清洗地板和其他硬质表面,它能渗透污垢、污渍,且不留下任何斑痕和垢膜。含有金属保护剂,不会对金属产生腐蚀。

成分特性: 非离子表面活性剂、碳酸钠、醇醚、EDTA。

用法用量: 建议一般污垢按10%~20%的比例兑入清水中,严重污垢可直接使用。

注意事项: 避免触及眼睛,若已接触,立即用大量清水冲洗。切勿入口。使用时建议戴上防护手套。

Use features: This product is a multi-purpose cleaner and it is suitable for cleaning the floor and other hard surfaces. Meanwhile, it can penetrate dirt and stain but not leave any black spots and scars and fouling membrane. Because it contains metal protective agent, it will not corrode metal.

Ingredient characteristics: Nonionic surfactant, sodium carbonate, alcohol ether and EDTA.

Usage and dosage: It is recommended that the product is mixed in the clear water in the proportion 10%~20%. It can be directly used to remove the severe dirt.

Note: Avoid touching the eyes. In case of contact, rinse immediately with plenty of water. Never eating. It is suggested to wear protective gloves when using.

DFF007

高泡地毯清洁剂 CARPET SHAMPOO-HIGH FOAM



SUPER CLEAN 品牌
Super-clean Brand



KIMBO 品牌
KIMBO Brand



深海洁品牌
Sea Clean Brand



驰丽洁品牌
ChiLiJie Brand

包装容量 Packing Capacition:3.8L/19L

用途特点: 本品为专业地毯除渍清洁剂。微黄液体。适用于各种长短毛毯。高浓度配方,泡沫丰富.去渍力强.洗后令地毯光洁、柔软、蓬松,鲜艳如新。如配合多功能洗地毯机使用,效果更佳。

成分特性: 非离子活性物、阴离子活性物、丙烯酸聚合物、香精。透明液体、紫金纺香。

用法用量: 用 1 份本品兑 20 份水,加入洗地毯机清水箱内即可。

注意事项: 使用时勿混入化泡剂,否则影响泡沫生成。

Use features: This product is a professional detergent for removing stains on the carpet. It is a light yellow liquid and shows a smell. It is suitable for all kinds of long and short blankets. It is characterized by high concentration formula, rich foam and strong stains removal capability. After the carpet is washed, it becomes smooth, soft, fluffy and bright as new one. If it is matched with multi-function carpet washer for using, the effect is better.

Ingredient characteristics: Non-ionic surfactant, anionic surfactant, acrylic polymer, flavor. Micro yellow liquid and lavender fragrance.

Usage and dosage: The product is diluted by the clear water in the ratio of 1:20 and then added to the water tank of the carpet cleaner.

Note: It shall not be mixed the foam agent, otherwise it affects the foam generation.

DFF008

低泡地毯清洁剂 LOW FOAM CARPET CLEANER



SUPER CLEAN 品牌
Super-clean Brand



KIMBO 品牌
KIMBO Brand



深海洁品牌
Sea Clean Brand



驰丽洁品牌
ChiLiJie Brand

包装容量 Packing Capacition:3.8L/19L

用途特点: 本品为专业地毯除渍清洁剂。微黄液体。适用于各种长短毛毯。高浓度配方,泡沫特少,去渍力强.洗后令地毯光洁柔软、富有弹性、鲜艳如新。如配合蒸汽式洗地毯机使用,效果更佳。

成分特性: 非离子活性物、丙烯酸聚合物、香精。无色或微黄色、紫金纺香。

用法用量: 用 1 份本品兑 12 份水,加入洗地毯机清水箱内即可。

注意事项: 避免触及眼睛,若已接触,立即用大量清水冲洗。切勿入口。使用时建议戴上防护手套。

Use features: This product is a professional detergent for removing stains on the carpet. It is a light yellow liquid and shows a smell. It is suitable for all kinds of long and short blankets. It is characterized by high concentration formula, little foam and strong stains removal capability. After the carpet is washed, it becomes smooth, soft, elastic, and bright as new one. If it is matched with the steam-type carpet washer for using, the effect is better.

Ingredient characteristics: Non-ionic surfactant, acrylic polymer and flavor. Colorless or yellowish and lavender fragrance.

Usage and dosage: The product is diluted by the clear water in the ratio of 1:12 and then added to the water tank of the carpet cleaner.

Note: Avoid touching the eyes. In case of contact, rinse immediately with plenty of water. Never eating. It is suggested to wear protective gloves when using.

DFF009 地毯起渍剂

CARPET STAIN CLEANER



SUPER CLEAN 品牌
Super-clean Brand



KIMBO 品牌
KIMBO Brand



深海洁品牌
Sea Clean Brand



驰丽洁品牌
ChiLiJie Brand

包装容量 Packing Capacition:3.8L/19L

用途特点:本品无色或微黄色。功效特强,适合清洗毛、麻、棉、各种化纤、混纺和尼龙、地毯上的茶渍、咖啡、油渍、饮料等污渍,本品对地毯无任何损伤。

成分特性:非离子活性物、氢氧化钾、溶剂、香精。无色或微黄色、紫金纺香。

用法用量:倒少许本品先喷洒在地毯的污渍上,再用清洗机清洗即可。

注意事项:使用前先沾少量清洁剂在不明显地方试,如掉色即停止使用。避免触及眼睛,若已接触,立即用大量清水冲洗。切勿入口。使用时建议戴上防护手套。

Use features:This product is colorless or yellowish and shows fragrance. Its effect is particularly strong and it is suitable for cleaning wool, linen, cotton, chemical fibers, blends and nylon and all stains on the carpet such as tea stains, coffee, grease stains and beverage. This product won't damage the carpet.

Ingredient characteristics:Nonionic surfactant, potassium hydroxide, solvent and flavor. Colorless or yellowish, lavender fragrance.

Usage and dosage:Spray a little of this product on the carpet stains and then wash them with the carpet cleaner.

Note:Test for fading before use,avoid touching the eyes. In case of contact, rinse immediately with plenty of water. Never eating. It is suggested to wear protective gloves when using.



DFF011

全能清洁剂（碱性配方）

MULTI-PURPOSE ALKALINE CLEANER



SUPER CLEAN 品牌
Super-clean Brand



KIMBO 品牌
KIMBO Brand



深海洁品牌
Sea Clean Brand



驰丽洁品牌
ChiLiJie Brand

包装容量 Packing Capacition:3.8L/19L

用途特点: 本品为翠绿色, 绿茶香。能去除油渍、炭渍、胶渍等。无腐蚀性, 安全可靠, 可用于瓷砖、塑料、金属、橡胶等表面, 是家庭及企事业单位普遍选用的清洁用品。

成分特性: 非离子表面活性剂、阴离子表面活性剂、助洗剂、溶剂。翠绿色、绿茶香。

用法用量: 一般表面清清, 用 1 份本品兑水 100 份, 用抹布揩拭。地板清洗, 用 1 份本品兑水 40 份, 进行清洗。顽固污渍与油胶清洗, 用 1 份本品兑水 5 份, 用喷雾瓶喷洒, 再用抹布揩拭。

注意事项: 避免触及眼睛, 若已接触, 立即用大量清水冲洗。切勿入口。使用时建议戴上防护手套。

Use features: This product is emeralal and shows scent of green tea. It enables to remove grease stains, carbon stains and glue stains etc. It is safe and reliable, without any corrosion. It can be used for ceramic tile, plastic, metal, rubber and other surfaces. It is an ordinary product chosen by the families, enterprises and institutions.

Ingredient characteristics: Nonionic surfactant, anionic surfactant, auxiliary agent and solvent. Emerald and scent of green tea.

Usage and dosage: Of cleaning an ordinary surface, the product is diluted by the clear water in the ratio of 1:100 and then the rag is used to wipe. Of cleaning the floor, the product is diluted by the clear water in the ratio of 1:40 to clean. Of cleaning stubborn stains and factice, the product is diluted by the clear water in the ratio of 1:5 and then a spray bottle is used to spray the product and the rag to wipe.

Note: Avoid touching the eyes. In case of contact, rinse immediately with plenty of water. Never eating. It is suggested to wear protective gloves when using.

DFF011

全能清洁剂（中性配方）

GENERAL PURPOSE CLEANER(NEUTRAL)



SUPER CLEAN 品牌
Super-clean Brand



KIMBO 品牌
KIMBO Brand



深海洁品牌
Sea Clean Brand



驰丽洁品牌
ChiLiJie Brand

包装容量 Packing Capacition:3.8L/19L

用途特点: 本品为翠绿色, 绿茶香。能去除油渍、炭渍、胶渍等。无腐蚀性, 安全可靠, 可用于瓷砖、塑料、金属、橡胶等表面, 是家庭及企事业单位普遍选用的清洁用品。

成分特性: 非离子表面活性剂、阴离子表面活性剂、助洗剂、溶剂、香精。翠绿色、绿茶香。

用法用量: 一般表面清清, 用 1 份本品兑水 100 份, 用抹布揩拭。地板清洗, 用 1 份本品兑水 40 份, 进行清洗。顽固污渍与油胶清洗, 用 1 份本品兑水 5 份, 用喷雾瓶喷洒, 再用抹布揩拭。

注意事项: 避免触及眼睛, 若已接触, 立即用大量清水冲洗。切勿入口。使用时建议戴上防护手套。

Use features: This product is emeralal and shows scent of green tea. It enables to remove grease stains, carbon stains and glue stains etc. It is safe and reliable, without any corrosion. It can be used for ceramic tile, plastic, metal, rubber and other surfaces. It is an ordinary product chosen by the families, enterprises and institutions.

Ingredient characteristics: Nonionic surfactant, anionic surfactant, auxiliary agent and solvent. Emerald and scent of green tea.

Usage and dosage: Of cleaning an ordinary surface, the product is diluted by the clear water in the ratio of 1:100 and then the rag is used to wipe. Of cleaning the floor, the product is diluted by the clear water in the ratio of 1:40 to clean. Of cleaning stubborn stains and factice, the product is diluted by the clear water in the ratio of 1:5 and then a spray bottle is used to spray the product and the rag to wipe.

Note: Avoid touching the eyes. In case of contact, rinse immediately with plenty of water. Never eating. It is suggested to wear protective gloves when using.

DFF012 化泡剂

ANTIFOAM



SUPER CLEAN 品牌
Super-clean Brand



KIMBO 品牌
KIMBO Brand



深海洁品牌
Sea Clean Brand



驰丽洁品牌
ChiLiJie Brand

包装容量 Packing Capacition:3.8L/19L

用途特点: 本品为乳白色,无香气。可用于减除各种水质泡沫,特别适用于硷化物形成的泡沫。适用于地毯、沙发清洗机使用。

成分特性: 乳化二甲硅氧烷、溶剂。

用法用量: 启动机器前,将化泡剂直接倒进清洗机污水箱内即可,每10升容器建议加入25-35ml化泡剂原液。

注意事项: 避免触及眼睛,若已接触,立即用大量清水冲洗。切勿入口。使用时建议戴上防护手套。

Use features: This product is milky white without fragrance. It can be used to reduce water foam, especially the form formed by alkalide. It is suitable for carpet and sofa washers.

Ingredient characteristics: Emulsified dimethyl siloxane and solvent.

Usage and dosage: Before starting the machine, the anti-form is directly poured into the sewage tank of the cleaning machine. It is suggested to add 25-35ml anti-form liquid per 10 liters container.

Note: Avoid touching the eyes. In case of contact, rinse immediately with plenty of water. Never eating. It is suggested to wear protective gloves when using.

DFF013 起蜡水

STRIPPER



SUPER CLEAN 品牌
Super-clean Brand



KIMBO 品牌
KIMBO Brand



深海洁品牌
Sea Clean Brand



驰丽洁品牌
ChiLiJie Brand

包装容量 Packing Capacition:3.8L/19L

用途特点: 本品无色或微黄色,略带氨味,为强力快捷除蜡除渍剂。有强渗透和溶解功效,能快速有效溶解各种蜡质及其它油状物质,是地板重新上蜡之前的必需用品。使用时无需擦地机磨刷。

成分特性: 非离子表面活性剂、氢氧化钠、氧化氨。无色或微黄色,略带氨味。

用法用量: 先用1份本品兑4份水,再用涂蜡拖布将要除蜡的地方涂抹,并使湿润状态保持约10分钟,然后用擦地机进行清洗。如果要清除严重蜡面污渍,则用1份本品兑2份水。

注意事项: 避免触及皮肤及眼睛,若已接触,立即用大量清水冲洗。切勿入口。使用时建议戴上防护手套。

Use features: This product, colorless or slightly yellow, is a strong and fast wax and stain stripper, with a slight ammonia smell. It is proud of a powerful penetration and dissolving effect, that is, it can quickly and effectively dissolve various waxes and other oily substances. It is a necessity before the floor is re-coated with the wax. When using, it is not necessary to use the floor wiping machine to brush.

Ingredient characteristics: Nonionic surfactant, sodium hydroxide and ammonia oxide. Colorless or slightly yellow, a slight smell of ammonia.

Usage and dosage: First, the product is diluted by the clear water in the ratio of 1:4 and then use the mop mixed with the wax to smear the place in which the wax is to be removed. After the wet status is maintained for about 10 minutes, use a floor polishing machine to clean. If it intends to remove serious wax surface stains, the product is diluted by the clear water in the ratio of 1:2.

Note: Avoid touching the eyes. In case of contact, rinse immediately with plenty of water. Never eating. It is suggested to wear protective gloves when using.

DFF014

中性消毒剂(绿水)

粤卫消证字[2025]-01-第8037号

GENERAL PURPOSE CLEANER(NEUTRAL ANTIBACTERIAL CLEANER)



SUPER CLEAN 品牌
Super-clean Brand



KIMBO 品牌
KIMBO Brand



深海洁品牌
Sea Clean Brand



驰丽洁品牌
ChiLiJie Brand

包装容量 Packing Capacition:3.8L/19L

用途特点: 本品为翠绿色, 松香香型, 中性配方, 具有的消毒作用。是日常保养地板的必需品。其气味清新, 泡沫小, 渗透力极强, 能快速清除地面污渍而不损伤蜡面光泽。拖抹后不需过水, 蜡面经磨光处理后更加光亮。

成分特性: 非离子表面活性剂、阴离子表面活性剂、对氯间二甲苯酚。翠绿色、松香香型。

用法用量: 一般表面清洁, 取1份本品兑入30份清水中, 拖抹蜡面地板。重度污渍表面清洁, 取1份本品兑入4份清水中, 拖抹蜡面地板, 再补蜡抛光。

注意事项:

避免触及皮肤及眼睛, 若已接触, 立即用大量清水冲洗。切勿入口。使用时建议戴上防护手套。

Use features: This product is emerald and shows pine scent. Although it is neutral formula, it has a disinfection effect. It is a necessity for daily floor maintenance. It is proud of fresh smell, little foam and strong penetration. It enables to quickly remove the surface stains but not damage the wax gloss. No rinsing is required after wiping. The wax surface is brighter after polishing.

Ingredient characteristics: Nonionic surfactant, anionic surfactant and PCMX. Emerald and pine scent.

Usage and dosage: Of cleaning an ordinary surface, the product is diluted by the clear water in the ratio of 1:30 and then the wax floor is wiped.

Of cleaning a severe stain surface, the product is diluted by the clear water in the ratio of 1:4 and then the wax floor is wiped and polished by the wax later.

Note: Avoid touching the eyes. In case of contact, rinse immediately with plenty of water. Never eating. It is suggested to wear protective gloves when using.

DFF015

洗石水

STONE CLEANER



SUPER CLEAN 品牌
Super-clean Brand



KIMBO 品牌
KIMBO Brand



深海洁品牌
Sea Clean Brand



驰丽洁品牌
ChiLiJie Brand

包装容量 Packing Capacition:3.8L/19L

用途特点: 本品为橘红色, 略带刺激气味, 强酸性。能快速除去马赛克及花岗石面上的顽固污渍, 锈渍, 去污力特强。

成分特性: 盐酸、硝酸等复合酸, 缓蚀剂。橘红色、略带刺激气味。

用法用量: 使用时视污渍程度, 将本品缓慢兑入清水中, 稀释 20-50 倍, 即可使用。

注意事项: 存放在阴凉背光处。使用时穿戴应防护用品, 不可接触皮肤和入口入眼。

一旦误入应立即用大量清水冲洗, 必要时寻求医生帮助。

Use features: This product, jacinth, is a strong acid and shows a slightly irritative smell. Thanks to its strong detergency, it enables to quickly remove stubborn stains and rust stains on the surface of the granite and mosaics.

Ingredient characteristics: Hydrochloric acid, nitric acid and other compound acids. Jacinth and slightly irritative smell.

Usage and dosage: When the product is used, it is diluted by the clear water in the ratio of 1:20-1:50, depending on the stains.

Note: It is stored in a cool and shade place. Wear protective equipment when using. Do not touch the skin, mouth and eyes. If so, rinse immediately with plenty of water. Consult the doctors when necessary.

DFF016

空气清新剂

AIR FRESHENER



SUPER CLEAN 品牌
Super-clean Brand



KIMBO 品牌
KIMBO Brand



深海洁品牌
Sea Clean Brand



驰丽洁品牌
ChiLiJie Brand

包装容量 Packing Capacition:3.8L/19L

用途特点: 本品为微红色,具玉兰香气味。有清新空气,消除环境的异味和臭气的功效。

成分特性: 乳化剂、香精。微红色、玉兰香。

用法用量: 用原液直接喷到物件表面或空间。也可用水稀释 3-5 倍后喷洒。

注意事项: 存放在阴凉背光处,防止误食。

Use features: This product is reddish and shows YuLan fragrance. It has the effect of refreshing air and eliminating the environmental odor and bad smell.

Ingredient characteristics: Emulsifier and essence. Reddish and YuLan fragrance.

Usage and dosage: The liquid is directly sprayed to the surface of the object or space. Or it may be sprayed after it is diluted by water for 3-5 times.

Note: It is stored in a cool and shade place and do not swallow.

DFF017

铝品光亮剂

ALUMINUM CLEANER



SUPER CLEAN 品牌
Super-clean Brand



KIMBO 品牌
KIMBO Brand



深海洁品牌
Sea Clean Brand



驰丽洁品牌
ChiLiJie Brand

包装容量 Packing Capacition:3.8L/19L

用途特点: 本品无色刺激性气味。能消除金属表面的锈斑,适合铝、铝合金、不锈钢、铁器等表面清洁。

成分特性: 非离子表面活性剂、磷酸、缓蚀剂。无色、刺激性气味。

用法用量: 用干布蘸本品反复擦拭金属表面至光亮,最后用清水洗净金属物品。

注意事项: 使用时应戴防护手套,不可入眼入口。一旦误入应立即用清水冲洗。

Use features: This product is colorless and shows irritative smell. It enables to eliminate the metal surface rust and it is suitable for cleaning aluminum, aluminum alloy, stainless steel, iron and other surfaces.

Ingredient characteristics: Nonionic surfactant, phosphoric acid and corrosion inhibitor. Colorless and irritative smell.

Usage and dosage: Use a dry cloth to dip this detergent to wipe the metal surface repeatedly until it is bright. At last, use clear water to clean metal items.

Note: Wear protective gloves when using. Do not touch mouth and eyes, otherwise, rinse immediately with plenty of water.

DFF018 特效洁厕剂

TOILET CLEANER



SUPER CLEAN 品牌
Super-clean Brand



KIMBO 品牌
KIMBO Brand



深海洁品牌
Sea Clean Brand



驰丽洁品牌
ChiLiJie Brand

包装容量 Packing Capacition:3.8L/19L

用途特点: 本品为蓝色液体, 海浪香型。适用于清洁尿槽、坐厕, 同时可清洗洗手盆、浴缸、瓷盘、瓷砖等表面污渍。去污力强, 除臭功能显著, 不会损伤物体表面, 清洗后, 留下清香气味。

成分特性: 非离子表面活性剂、阴离子表面活性剂、磷酸等复合酸、香精。蓝色、海浪香型。

用法用量: 用 1 份本品兑 6 份水, 将其喷洒到清洗物表面, 进行清洗, 数分钟后用清水过净即可。对所洗物表面材质不明者, 应先在不见的地方进行试验。如发现脱色、染色, 即用清水过净, 并立即停止使用。

注意事项: 避免触及皮肤及眼睛, 若已接触, 立即用大量清水冲洗。切勿入口。使用时建议戴上防护手套。

Use features: This product is a blue liquid and shows the sea wave flavor. It is suitable for cleaning toilet, urinal, bathtub, washbasin, dishes, ceramic tile and other surface stains. It is proud of strong detergency and deodorant function. Meanwhile, it will not damage the surface of the object. After cleaning, a scent smell drifts.

Ingredient characteristics: Nonionic surfactant, anionic surfactant, phosphoric acid and flavor etc. Blue and sea wave flavor.

Usage and dosage: The product is diluted by the clear water in the ratio of 1:6 and it is sprayed to the surface of the object for cleaning. After a few minutes, wash it with water. If the material nature of the washing surface is unknown, test one inconspicuous part of the product. In case of bleaching and dyeing, wash it with water and immediately stop using.

Note: Avoid touching the eyes and skin. In case of contact, rinse immediately with plenty of water. Never eating. It is suggested to wear protective gloves when using.

DFF019 酸性清洁剂

ACIDIC CLEANER



SUPER CLEAN 品牌
Super-clean Brand



KIMBO 品牌
KIMBO Brand



深海洁品牌
Sea Clean Brand



驰丽洁品牌
ChiLiJie Brand

包装容量 Packing Capacition:3.8L/19L

用途特点: 本品为红色液体, 略带刺激气味。适合于不能用碱性清洁剂进行清洗的物品, 如纸皮石、瓷、铜、不锈钢等的表面。

成分特性: 非离子表面活性剂、盐酸复合物。红色、略带刺激气味。

用法用量: 将少量清洁剂喷到清洗物表面, 用软布擦拭, 数分钟后用清水冲净。清洗浴盆、马赛克或水泥地面、铝钢表面等, 用 1 份本品兑 6 份水, 进行清洗。

注意事项: 避免触及皮肤及日良睛, 若已接触, 立即用大量清水冲洗。切勿入口。使用时建议戴上防护手套。对所洗物表面性质不明者, 应先在不见的地方进行试验, 如发现脱色、染色, 则用清水过净, 立即停止使用。

Use features: This product is red liquid and shows a slightly irritative smell. It is suitable for the articles that can't be cleaned by the alkaline cleaner, such as copper, ceramic tile, porcelain and stainless steel surfaces etc.

Ingredient characteristics: Nonionic surfactant and hydrochloric acid compound. Red and a slightly irritative smell.

Usage and dosage: Spray a small amount of cleaner to the surface of article subject to washing, wipe it with a soft cloth and rinse it with water after a few minutes. Wash bathtub, mosaic or cement floor and aluminum steel surface. The product is diluted by the clear water in the ratio of 1:6 for cleaning.

Note: Avoid touching the eyes and skin. In case of contact, rinse immediately with plenty of water. Never eating. It is suggested to wear protective gloves when using. If the material nature of the washing surface is unknown, test one inconspicuous part of the product. In case of bleaching and dyeing, wash it with water and immediately stop using.

DFF020

静电吸尘埃剂

ELECTROSTATIC PRECIPITATOR



SUPER CLEAN 品牌
Super-clean Brand



KIMBO 品牌
KIMBO Brand



深海洁品牌
Sea Clean Brand



驰丽洁品牌
ChiLiJie Brand

包装容量 Packing Capacition:3.8L/19L

用途特点: 本品为一种无色、具香蕉香气的专业地面保养用品,能增强地拖吸去污能力,吸尘后的地拖极易抖去尘土,再次使用。适合于打蜡地面、要求高清洁度地面等的使用。

成分特性: 异链烷烃溶剂、石油衍生物、香精。无色、香蕉香。

用法用量: 将本品喷在拖布上,待其漫透拖布后,即可拖地。拖布上尘土收集达到一定程度时,抖去尘土,接着使用。

注意事项: 远离火源存放。

Use features: This product is a colorless and professional ground maintenance supplies with a banana flavor. It can enhance the ability of mop to remove the dust. The mop, which is used to wipe the floor, easily shakes off the dust for using again. It is suitable for the floor waxing and the floor with high cleanliness requirement.

Ingredient characteristics: Isoalkane solvent, petroleum derivatives and essence. Colorless and banana flavor.

Usage and dosage: The product is sprayed on the mop. Once the mop is soaked with the product, wipe the floor. When the dust is collected on the mop to a certain extent, shake off the dust and then use it again.

Note: Keep away from fire.

DFF021

不锈钢保养剂

STAINLESS STEEL CLEANER



SUPER CLEAN 品牌
Super-clean Brand



KIMBO 品牌
KIMBO Brand



深海洁品牌
Sea Clean Brand



驰丽洁品牌
ChiLiJie Brand

包装容量 Packing Capacition:3.8L/19L

用途特点: 本品为无色、具有香蕉气味的不锈钢表面清洁保养剂。其去污力特强,能有效去除油污、锈渍。用后在不锈钢表面形成保护膜,能使金属表面保持光洁如新,防尘防手指印残留。

成分特性: 异链烷烃溶剂、石油衍生物、阳离子表面活性剂。无色、香蕉香。

用法用量: 倒少许本品于干净抹布上,擦拭不锈钢表面。

注意事项: 远离火源存放。

Use features: This product is colorless and stainless steel cleaner with a banana smell. It is proud of strong detergency and it can effectively remove oil stains and rust. After using, a protective film is formed on the surface of stainless steel so as to keep the metal surface as a new one and prevent dust and fingerprints from being left on it.

Ingredient characteristics: Isoalkane solvent, petroleum derivatives and cationic surfactant. Colorless and banana flavor.

Usage and dosage: Pour a little of this product on a clean cloth to wipe the surface of stainless steel.

Note: Keep away from fire.

DFF022 玻璃清洁剂

GLASS CLEANER



SUPER CLEAN 品牌
Super-clean Brand



KIMBO 品牌
KIMBO Brand



深海洁品牌
Sea Clean Brand



驰丽洁品牌
ChiLiJie Brand

包装容量 Packing Capacition:3.8L/19L

用途特点: 本品为蓝色液体,青苹果香气。适用于所有玻璃门窗、镜子及玻璃用具清洁。使用方便,去污力强,能使玻璃表面恢复晶莹通透,无需过水,不留痕迹。可溶解吸附玻璃上的各种污垢。

成分特性: 非离子表面活性剂、溶剂。蓝色、青苹果香。

用法用量: 用本品 1 份兑清水 4 份,用涂水器或擦窗器擦拭玻璃。

注意事项: 勿与其他清洁剂混用。

Use features: This product is blue liquid and shows a green apple aroma. It is suitable for cleaning all glass doors, windows, mirrors and glass utensils. It is easy to use and it is proud of strong detergency. It enables to restore the glass surface to crystal clear, without rinsing and traces. Furthermore, it can dissolve all dirt and stains on the glass.

Ingredient characteristics: Nonionic surfactant, solvent. Blue and green apple flavor.

Usage and dosage: The product is diluted by the clear water in the ratio of 1:4. Use a water sprayer or a window wiper to wipe the glass.

Note: Don't mix it with other chemical cleaners.

DFF023 强力外墙清洁剂

STRONG-EFFECT WALL CLEANER



SUPER CLEAN 品牌
Super-clean Brand



KIMBO 品牌
KIMBO Brand



深海洁品牌
Sea Clean Brand



驰丽洁品牌
ChiLiJie Brand

包装容量 Packing Capacition:3.8L/19L

用途特点: 本品无色、略有刺鼻气味,对瓷砖、马赛克等硬质表面有非同一般的洗涤效果。对特脏及长时间的污垢,效果更佳。

成分特性: 非离子表面活性剂、盐酸、硝酸、复合酸、缓蚀剂。

用法用量: 用本品原液直接喷洒在污渍处,稍等片刻,再清水冲洗干净即可。

注意事项: 存放在阴凉背光处。使用时穿戴防护用具,不触及皮肤和眼睛,如误触及请即时用大量清水冲洗,必要时寻求医生帮助。

Use features: This product is colorless and shows a slightly irritative smell. It is proven to present remarkable washing effect on ceramic tile, mosaic and other hard surfaces, especially on the extremely dirt and stubborn stains.

Ingredient characteristics: Nonionic surfactant, hydrochloric acid, nitric acid, compound acid and corrosion inhibitor.

Usage and dosage: The product liquid is directly sprayed on the stains. After waiting a moment, rinse it with the clear water.

Note: It is stored in a cool and shade place. Wear protective equipment when using. Do not touch the skin and eyes. Otherwise, rinse immediately with plenty of water. Consult the doctors if necessary.

DFF024

浴室清洁剂

BATHROOM CLEANER



SUPER CLEAN 品牌
Super-clean Brand



KIMBO 品牌
KIMBO Brand



深海洁品牌
Sea Clean Brand



驰丽洁品牌
ChiLiJie Brand

包装容量 Packing Capacition:3.8L/19L

用途特点: 本品微兰色,有松香气味。适用于清洗浴缸、洗手盆、尿槽、坐厕、瓷盆、瓷砖等污渍,去污力强,洗后留下清香气味。

成分特性: 非离子表面活性剂、阴离子表面活性剂。微黄色、松香。

用法用量: 用 1 份本品兑 6 份水,将其喷洒到清洗物表面,用软布擦拭,数分钟后用清水冲洗。对所洗物表面材质不明者,应先在不显见的地方进行试验。如发现脱色、染色,即用清水洗净,立即停止使用。

注意事项: 避免触及皮肤及眼睛,若已接触,立即用大量清水冲洗。切勿入口。使用时建议戴上防护手套。

Use features: This product is blue and shows a rosin smell. It is suitable for cleaning bathtub, wash basin, trough urinal, water closet, porcelain bowl and porcelain brick stains. It is proud of strong detergency. After cleaning, a scent smell drifts.

Ingredient characteristics: Nonionic surfactant and anionic surfactant. Yellowish and rosin.

Usage and dosage: The product is diluted by the clear water in the ratio of 1:6 and it is sprayed to the surface of the object. Use the soft cloth to wipe. After a few minutes, wash it with water. If the material nature of the washing surface is unknown, test one inconspicuous part of the product. In case of bleaching and dyeing, wash it with water and immediately stop using.

Note: Avoid touching the eyes and skin. In case of contact, rinse immediately with plenty of water. Never eating. It is suggested to wear protective gloves when using.

DFF026

除胶剂

REMOVER



SUPER CLEAN 品牌
Super-clean Brand



KIMBO 品牌
KIMBO Brand



深海洁品牌
Sea Clean Brand



驰丽洁品牌
ChiLiJie Brand

包装容量 Packing Capacition:3.8L/19L

用途特点: 本品为无色液体,略带刺激气味。用于清除粘贴在地毯、衣物、沙发、鞋底等处的香口胶残渣。对地毯上小面积重油污、油漆、鞋油及各种油性斑痕的清除均有特效。

成分特性: 石油衍生物、卤代烃。无色,刺鼻气味。

用法用量: 将除胶剂喷洒于污渍处(时间较长的胶垢需浸 10 分钟)。然后反复揉刷,抹去胶渍。如污垢严重,请重复使用。

注意事项: 请勿靠近火源,远离儿童,只供专业使用,用后请持紧瓶盖。

Use features: This product is a colorless liquid and shows a slightly irritative smell. It is used to remove the gum residue pasted on the carpet, clothing, sofa and soles etc. It is proven to have remarkable effect on heavy oil stains in small area of the carpet, paint, shoe polish and various oily stains.

Ingredient characteristics: Petroleum derivatives and halogenated hydrocarbons. Colorless and pungent odor.

Usage and dosage: The gum remover is sprayed on the stains(The stubborn gum dirt is required to be soaked for 10 minutes). And then brush it repeatedly until wipe the glue stains. In case of the severe dirt, please repeat operation.

Note: Do not close to the fire. Be away from children. It is provided only for professional use. Please tighten the cap after use.

DFF027

浴室消毒剂 粤卫消证字[2025]-01-第8037号 BATHROOM DISINFECTING CLEANER



SUPER CLEAN 品牌
Super-clean Brand



KIMBO 品牌
KIMBO Brand



深海洁品牌
Sea Clean Brand



驰丽洁品牌
ChiLiJie Brand

包装容量 Packing Capacition:3.8L/19L

用途特点: 本品为淡黄色液体,采用非离子表面活性剂与对氯间二甲基苯酚等多元复配而成。针对浴室的特殊环境而设计。对真菌、大肠杆菌、金色葡萄球菌具有杀灭作用。本品具消毒清洁功能于一体,使用后浴室能达到消毒卫生的要求。

主要成分: 非离子表面活性剂、对氯间二甲基苯酚、阴离子表面活性剂、螯合剂。

用法用量: 日常清洁消毒用 1 份本品兑 10 份水;特别严重污染区按 1:1 兑水使用。

原液具有高效的生物活性,根据不同使用情况,可以用水稀释 100~1000 倍使用。

注意事项: 建议使用时戴上防护手套,避免皮肤接触;外用消毒剂禁止口服,置于儿童不易触及处。

Applications& Features: This product is faint-yellow liquid. It is made from non-ionic surfactant and PCMX. It is designed for special environment of bathroom. It can kill funguses, Escherichia coli and staphylococcus aureus. It possesses the disinfecting and cleaning functions, so it can make a bathroom meet the disinfection and sanitary requirements.

Main Compositions: Non-ionic surfactant, PCMX, cationic surfactant, chelating agent.

Usage and Dosage: This product is diluted with water at the dilution rate of 1:10 for daily cleaning and disinfection; and it is diluted with water at the dilution rate of 1:1 for a especially seriously polluted area. The pure liquid possesses efficient biological activity and can be used after being diluted with water for 100-1000 times as per different purposes.

Considerations: When using this product, it is necessary to wear protective gloves to prevent your skin from contacting this product; it is for external use, so it is prohibited to take it orally. In addition, it should be kept out of children's reach.

DFF028

干泡地毯清洁剂 DRY FOAM RUG SHAMPOO



SUPER CLEAN 品牌
Super-clean Brand



KIMBO 品牌
KIMBO Brand



深海洁品牌
Sea Clean Brand



驰丽洁品牌
ChiLiJie Brand

用途特点: 本品为专业地毯除渍清洁剂。无色液体,艾草香味。适用于各种长短毛毯。高浓度配方,泡沫丰富,去渍力强。洗后令地毯光洁、柔软、蓬松,鲜艳如新。如配合多功能洗地毯机使用,效果更佳。

成分特性: 非离子活性物、阴离子活性物、丙烯酸聚合物、香精。无色液体、艾草香味。

用法用量: 用 1 份本品兑 20 份水,加入洗地毯机清水箱内即可。

注意事项: 使用时勿混入发泡剂,否则影响泡沫生成。

Use features: This product is a professional detergent for removing stains on the carpet. It is a colorless liquid and shows a argy wormwood smell. It is suitable for all kinds of long and short blankets. It is characterized by high concentration formula, rich foam and strong stains removal capability. After the carpet is washed, it becomes smooth, soft, fluffy and bright as new one. If it is matched with multi-function carpet washer for using, the effect is better.

Ingredient characteristics: Non-ionic surfactant, anionic surfactant, acrylic polymer, flavor. colorless liquid and argy wormwood fragrance.

Usage and dosage: The product is diluted by the clear water in the ratio of 1:20 and then added to the water tank of the carpet cleaner.

Note: It shall not be mixed the foam agent, otherwise it affects the foam generation.

包装容量 Packing Capacition:3.8L/19L



超洁亮专业清洁剂实验室
Research And Development Room

DFG001

强力高漂洗衣粉

STRONG DETERGENT POWDER



SUPER CLEAN 品牌
Super-clean Brand



KIMBO 品牌
KIMBO Brand



深海洁品牌
Sea Clean Brand



驰丽洁品牌
ChiLiJie Brand

包装容量 Packing Capacition:20kg

用途特点: 本品为白色粉末状,能很好地去除织物组织的严重污垢,对棉、麻织物的动、植物油重污垢有显著的洁净功效,省时省力(本品不可用于手洗)。

成分特性: 表面活性剂、水处理剂、苛性碱。

用法用量: 视洗涤织物数量和污垢程度,取本品若干完全溶于清水,再将被洗涤织物浸入水中洗涤。洗涤后用清水漂洗 2-3 次即可。将清水加热至 60°C ~80°C 时,去污效果更好。

注意事项: 存放时应防潮。结块时应完全碾碎后使用。防止误食,误食后应寻求医生帮助。

Use features: This product is white powder. It enables to remove the serious dirt on the fabrics. Additionally, it is proven to have a remarkable cleaning effect on heavy animal and vegetable oil stains in cotton, linen fabrics. Save time and effort(it can not be used washing by the hands).

Ingredient characteristics: Surfactant, water treatment chemicals and caustic alkali.

Usage and dosage: Depending on the fabrics quantity and degree of dirt, this product is taken to completely dissolve in water. The fabrics, subject to washing, are soaked in water. After washing, rinse it with clean water for 2-3 times. When the clear water is heated to 60°C ~80°C, the detergency effect is much better.

Note: Damp proof measures shall be taken when storing. In case of caking, it shall be used after completely crushed. Do not swallow. Otherwise, consult the doctors right away.

DFG002

增白彩漂洗衣粉

COMMON DETERGENT POWDER



SUPER CLEAN 品牌
Super-clean Brand



KIMBO 品牌
KIMBO Brand



深海洁品牌
Sea Clean Brand



驰丽洁品牌
ChiLiJie Brand

包装容量 Packing Capacition:20kg

用途特点: 本品为白色粉末状,由高活性物组成。能迅速渗透到织物内层,不但去污能力强。且性质安全温和,不伤织物,再配以特殊的荧光增白剂,更能保持织物的鲜艳光亮。可机洗手洗,省时省力。

成分特性: 表面活性剂、增白剂、过碳酸钠。

用法用量: 推荐每 45~50kg 布草使用本品 200~300g,取本品完全溶于 60°C -80°C 清水,再将被洗涤织物浸入水中洗涤。洗涤后用清水漂洗 2-3 次即可。

注意事项: 存放时应防潮。结块时应完全碾碎后使用。防止误食,误食后应寻求医生帮助。

Use features: This product is a white powder and it is made of high activity substance. It enables to quickly penetrate into the fabric lining but also has strong detergency. Its nature is safe and gentle and it won't damage the fabrics. If a special fluorescent whitening agent is added, the bright fabrics can be kept. It can be used no matter washing by the machine and by hands. Save time and effort.

Ingredient characteristics: Surfactant, brightening agent and sodium percarbonate.

Usage and dosage: It is recommended that 200~300g powder used per 45~50kg clothes. This product is taken to completely dissolve in 60°C -80°C clear water. The fabrics, subject to washing, are soaked in water. After washing, rinse it with clean water for 2-3 times.

Note: Damp proof measures shall be taken when storing. In case of caking, it shall be used after completely crushed. Do not swallow. Otherwise, consult the doctors right away.

DFG003

低温酵素洗衣粉

FERMENT DETERGENT POWDER



SUPER CLEAN 品牌
Super-clean Brand



KIMBO 品牌
KIMBO Brand



深海洁品牌
Sea Clean Brand



驰丽洁品牌
ChiLiJie Brand

包装容量 Packing Capacition:20kg

用途特点: 本品为白色粉末状, 由生物活性酶为基料配制的洗衣粉。专门适应不能使用高温的织物洗涤。其独特的生物活性酶, 能迅速分解织物上的汗迹、血迹、油脂及蛋白质等污垢。可机洗手洗, 清洁效果显著, 且不伤织物。

成分特性: 表面活性剂、硅酸钠、酵素。

用法用量: 推荐每 45~50kg 布草使用本品 300g, 取本品完全溶于常温清水, 再将被洗涤织物浸入水中洗涤。洗涤后用清水漂洗 2-3 次即可。

注意事项: 存放时应防潮。结块时应完全碾碎后使用。防止误食, 误食后应寻求医生帮助。

Use features: This product is white detergent powder and it is prepared by the biological active enzyme as the base material. It is specially used for cleaning the fabrics that can't be cleaned in high temperature. Thanks to its unique biological activity enzyme, it can quickly decompose sweat stains, blood, grease and protein and other dirt on the fabric. It can be used no matter washing by the machine and by hands. Cleaning effect is significant. It doesn't damage the fabrics.

Ingredient characteristics: Surfactant, sodium silicate and enzyme.

Usage and dosage: It is recommended that 300g powder is used per 45~50kg clothes. This product is taken to completely dissolve in the ambient temperature water. The fabrics, subject to washing, are soaked in water. After washing, rinse it with clean water for 2-3 times.

Note: Damp proof measures shall be taken when storing. In case of caking, it shall be used after it is completely crushed. Do not swallow. Otherwise, consult the doctors right away.

DFG004

氯漂粉

BLEACH POWDER



SUPER CLEAN 品牌
Super-clean Brand



KIMBO 品牌
KIMBO Brand



深海洁品牌
Sea Clean Brand



驰丽洁品牌
ChiLiJie Brand

包装容量 Packing Capacition:20kg

用途特点: 本品是白色粉末状, 由高效的有机氯组成的漂白剂。其分解出的活性氯, 能迅速漂白去污, 且不伤织物。

成分特性: 二氯异氰尿酸钠、硫酸钠、粉剂。

用法用量: 推荐每 45~50kg 布草使用本品 100~200g, 限白色布草使用。取本品完全溶于 60°C -80°C 清水, 再将需漂白的涤织物浸入水中。漂白后用清水漂洗 2-3 次即可。

注意事项: 存放时远离酸性清洁剂, 注意防潮。结块时应完全碾碎后使用。防止误食, 误食后应寻求医生帮助。

Use features: This product is a white bleach powder made of high efficiency organic chlorine. The active chlorine decomposed by it can rapidly bleach and remove dirt. It doesn't damage the fabrics.

Ingredient characteristics: Sodium dichloroisocyanurate, sodium sulfate and powder.

Usage and dosage: It is recommended that 100-200g powder used per 45~50kg clothes. It is only limited to use for washing white clothes. This product is taken to completely dissolve in 60 °C -80 °C clear water. The fabrics, subject to washing, are soaked in water. After washing, rinse it with clean water for 2-3 times.

Note: 1. Keep away from acidic cleaner, pay attention to moistureproof. In case of caking, it shall be used after completely crushed. Do not swallow. Otherwise, consult the doctors right away.

DFG005

彩漂粉

OXYGEN BLEACH POWDER



SUPER CLEAN 品牌
Super-clean Brand



KIMBO 品牌
KIMBO Brand



深海洁品牌
Sea Clean Brand



驰丽洁品牌
ChiLiJie Brand

包装容量 Packing Capacition:20kg

用途特点: 本品是高效活性氧组成的漂白剂, 漂白效率高, 并具去污能力, 不伤织物。

成分特性: 过碳酸钠、硫酸钠、粉剂。

用法用量: 推荐每 45~50kg 布草使用本品 100~200g, 可配合强力高漂洗衣粉、增白彩漂洗衣粉使用。取本品完全溶于 60°C -80°C 清水, 再将需彩漂的涤织物浸入水中。彩漂后用清水漂洗 2-3 次即可。

注意事项: 存放时应防潮。结块时应完全碾碎后使用。防止误食, 误食后应寻求医生帮助。

Use features: This product is bleach powder made of high efficiency reactive oxygen. It is proud of high bleaching efficiency and detergency. It doesn't damage the fabrics.

Ingredient characteristics: Sodium percarbonate, sodium sulfate and powder

Usage and dosage: It is recommended that 100-200g powder used per 45~50kg clothes. It can be used together with the high efficiency bleach powder and whitening bleach powder. This product is taken to completely dissolve in 60°C -80°C clear water. The fabrics, subject to bleaching, are soaked in water. After bleaching, rinse it with clean water for 2-3 times.

Note: Damp proof measures shall be taken when storing. In case of caking, it shall be used after completely crushed. Do not swallow. Otherwise, consult the doctors right away.

DFG006

浆粉

STARCH



SUPER CLEAN 品牌
Super-clean Brand



KIMBO 品牌
KIMBO Brand



深海洁品牌
Sea Clean Brand



驰丽洁品牌
ChiLiJie Brand

包装容量 Packing Capacition:10kg

用途特点: 本品为白色粉末状, 由特殊配方制成的升华浆粉, 具有良好的上浆效能, 令织物挺拔平滑, 防止织物起毛, 并有一定的增白效果。

主要成分: 淀粉、助剂、粉剂。白色粉末。

用法用量: 推荐每 45~50kg 布草使用本品 200~300g。

注意事项: 存放时应防潮, 结块时不应继续使用。不能与其他洗涤剂混合使用。防止误食, 误食后应寻求医生帮助。

Use features:

This product is white powder sublimation starch prepared by the special formula. It is proud of good sizing efficiency. After using, the fabrics are straight and smooth. It enables to prevent the fabrics from pilling and whiten fabrics.

Ingredient characteristics:

Starch, additives and powder. White powder.

Usage and dosage:

It is recommended that 200-300g powder is used per 45~50kg clothes.

Note:

Damp proof measures shall be taken when storing. In case of caking, it shall not be used any more. Do not mix it with other chemical cleaners. Do not swallow. Otherwise, consult the doctors right away.

DFG007 除锈酸

RUST REMOVER ACID



SUPER CLEAN 品牌
Super-clean Brand



KIMBO 品牌
KIMBO Brand



深海洁品牌
Sea Clean Brand



驰丽洁品牌
ChiLiJie Brand

包装容量 Packing Capacition:20kg

用途特点: 本品为粉剂, 主要用于清除水质中的铁、钙离子在织物上生成的锈斑。其独特的除锈配方, 能迅速高效地螯合铁、镁、钙离子, 适用于棉、麻、化纤、混纺或其它合成织物。

成分特性: 氟硅酸钠、除锈剂、粉剂。

用法用量: 推荐每 45~50kg 布草使用本品 200g。将本品溶入常温清水中, 再将织物浸入水中漂洗 15 分钟。

注意事项: 存放时应防潮, 结块时不应继续使用。不能与其他洗涤剂混合使用。防止误食, 误食后应寻求医生帮助

Use features: This powder, is mainly used for removing fabric rust generated from iron and calcium ions in water. Thanks to unique rust removal formula, it can quickly and efficiently chelate iron, magnesium and calcium ions, while it is suitable for cotton, linen, chemical fiber, blended fiber or other synthetic fabrics.

Ingredient characteristics: Sodium fluosilicate, rust remover and powder.

Usage and dosage: It is recommended that 200g powder is used per 45~50kg clothes. This product is taken to dissolve in the ambient temperature water and then the fabrics are soaked in water for 15 minutes.

Note: Damp proof measures shall be taken when storing. In case of caking, it shall not be used any more. Don't mix it with other chemical cleaners. Do not swallow. Otherwise, consult the doctors right away.

DFG008 荧光中和酸

FLUORESCENT ACID



SUPER CLEAN 品牌
Super-clean Brand



KIMBO 品牌
KIMBO Brand



深海洁品牌
Sea Clean Brand



驰丽洁品牌
ChiLiJie Brand

包装容量 Packing Capacition:20kg

用途特点: 本品为白色粉末, 是一种具独特荧光效能的酸性物质, 能中和织物中残留的碱性, 螯合水中的铁、钙; 其荧光组份, 能增加织物亮度, 使织物更显光亮鲜艳, 且不伤织物。

成分特性: 氟硅酸钠、助剂、粉剂。白色粉末。

用法用量: 推荐每 45~50kg 布草使用本品 300g, 将本品溶入常温清水中, 再将织物浸入水中漂洗 15 分钟。

注意事项: 存放时应防潮, 结块时不应继续使用。不能与其他洗涤剂混合使用。防止误食, 误食后应寻求医生帮助。

Use features: This white powder, is an acidic substance with the unique fluorescent effect. It enables to neutralize the alkali resided in the fabrics and chelate iron and calcium in water. Additionally, its fluorescent ingredient can enhance the brightness of the fabric and make the fabric brighter. It won't damage the fabrics.

Ingredient characteristics: Sodium silicate, additive and powder. White powder.

Usage and dosage: It is recommended that 300g powder is used per 45~50kg clothes. This product is taken to dissolve in the ambient temperature water and then the fabrics are soaked and bleached in water for 15 minutes.

Note: Damp proof measures shall be taken when storing. In case of caking, it shall not be used any more. Don't mix it with other chemical cleaners. Do not swallow. Otherwise, consult the doctors right away.

DFG009 油污乳化剂

STAINS EMULSIFIER



SUPER CLEAN 品牌
Super-clean Brand



KIMBO 品牌
KIMBO Brand



深海洁品牌
Sea Clean Brand



驰丽洁品牌
ChiLiJie Brand

包装容量 Packing Capacition:3.8L/19L

用途特点: 本品为无色液体, 具强劲乳化脱脂能力。配以特效渗透因子, 荧光素和表面活性剂, 确保织物上的任何顽固油污得以彻底清除。适用于棉、麻、混纺、聚酯及其他合成织物。

成分特性: 醇醚、表面活性剂、溶剂。无色。

用法用量: 推荐每 45~50kg 布草使用本品 500g, 配合强力高漂洗衣粉能有效去除重油污, 提升去污效率。

注意事项: 防止误食, 如有误食请寻求医生帮助。

Use features: This product, a colorless liquid, has a strong emulsification and degreases ability. By adding the special effect permeability factor, fluorescein and surfactant, ensure that any stubborn oil stains on the fabric can be completely removed. It is suitable for cotton, linen, blending, polyester and other synthetic fabrics.

Ingredient characteristics: Ether, surfactant, solvent. Colorless.

Usage and dosage: It is recommended that 500g product is used per 45~50kg clothes. By adding high-efficient bleaching powder for using, it can effectively remove heavy oil stains and improve the detergency.

Note: Prevent eating by mistake. If so, consult the doctors.

DFG010 织物柔顺剂

FABRIC SOFTENER



SUPER CLEAN 品牌
Super-clean Brand



KIMBO 品牌
KIMBO Brand



深海洁品牌
Sea Clean Brand



驰丽洁品牌
ChiLiJie Brand

包装容量 Packing Capacition:3.8L/19L

用途特点: 本品且具清新香味的液体。适用于无上浆织物, 如羊毛织物、混纺质料、毛巾、浴巾等。能迅速消除织物中的静电, 减少织物互相粘连, 使织物松软顺滑, 且具清新的香味。

成分特性: 阳离子表面活性剂、助剂。

用法用量: 推荐每 45~50kg 布草使用本品 50~100g, 将本品兑入常温清水中, 将织物浸泡水中 15 分钟。再用清水漂洗 2-3 遍。

注意事项: 防止误食, 如有误食请寻求医生帮助。

Use features: This product is a liquid with the fresh scent. It is suitable for the fabrics that are not sized, such as wool fabric, blended fabric, towel and bath towel. It enables to quickly eliminate the static electricity of fabrics and reduce the fabric adhesion, so that the fabric is soft and smooth, with a fresh scent.

Ingredient characteristics: Cationic surfactant and additive.

Usage and dosage: It is recommended that 50-100g product is used per 45~50kg clothes. This product is diluted in the ambient temperature water and then the fabrics are soaked for 15 minutes and then rinsed with clear water for 2-3 times.

Note: Prevent eating by mistake. If so, consult the doctors.

DFG011

丝毛洗涤剂

SILK&WOOL DETERGENT



SUPER CLEAN 品牌
Super-clean Brand



KIMBO 品牌
KIMBO Brand



深海洁品牌
Sea Clean Brand



驰丽洁品牌
ChiLiJie Brand

包装容量 Packing Capacition:3.8L/19L

用途特点: 本品为无色液体, 采用特殊的柔和护理配方。针对丝毛制品纤维幼细的特点在清洁的同时, 消除静电, 梳理纤维, 柔软蓬松, 保持织物天然光泽。

成分特性: 非离子表面活性剂、椰油酸烷醇酰胺、助剂。

用法用量: 推荐每 45~50kg 布草使用本品 100~200g, 将本品兑入常温清水中, 将织物在水中漂洗 10~15 分钟。再用清水漂洗 2-3 次。

注意事项: 不应与其它洗涤剂或洗衣粉混用。

Use features: This product, a colorless liquid, is prepared by a special soft care formula. Based on the fine feature of silk and wool fiber products, it needs to eliminate static electricity, tease and soften the fiber and keep its natural luster when cleaning.

Ingredient characteristics: Nonionic surfactant, coconut fatty acid alkanolamide and additive.

Usage and dosage: It is recommended that 100-200 g product is used per 45-50kg clothes. This product is diluted in the ambient temperature water and then the fabrics are soaked for 10-15 minutes and then rinsed with clear water for 2-3 times.

Note: Do not mix it with other cleaners or laundry soap powder.

DFG012

软水剂

WATER SOFTENER



SUPER CLEAN 品牌
Super-clean Brand



KIMBO 品牌
KIMBO Brand



深海洁品牌
Sea Clean Brand



驰丽洁品牌
ChiLiJie Brand

包装容量 Packing Capacition:20kg

用途特点: 本品为白色粉剂, 适应于硬水的快速软化, 可防止织物因硬水矿物质沉积而造成的黄色色斑。提高洗衣功效。

成分特性: NTA、EDTA、粉剂。

用法用量: 推荐每 45~50kg 布草使用本品 20~50g, 在洗衣机中将本品兑入清水中, 按机洗程序洗涤织物。本品适合任何温度下使用。

注意事项: 存放时应防潮湿, 已结块时不能使用。防止误食。

Use features: This product, a white powder, is suitable for rapid softening of hard water, while it can prevent the yellow stain on the fabric caused by the deposition of the hard water minerals. It can improve the laundry effect.

Ingredient characteristics: NTA, EDTA and powder

Usage and dosage: It is recommended that 20-50g product is used per 45-50kg clothes. The product is diluted in clear water in the washing machine and the fabrics are washed on the basis of the procedures in the machine. This product is suitable for using under any temperature.

Note: Damp proof measures shall be taken when storing. In case of caking, it shall not be used again. Prevent eating by mistake.

DFG013 衣领净 (预去斑剂)

PRE-DETERGENT



SUPER CLEAN 品牌
Super-clean Brand



KIMBO 品牌
KIMBO Brand



深海洁品牌
Sea Clean Brand



驰丽洁品牌
ChiLiJie Brand

包装容量 Packing Capacition:3.8L/19L

用途特点: 本品主要对油污及蛋白质引起的污垢有特效, 专用于衣物领口、袖口、袋门等局部重污垢预洗。

成分特性: 非离子表面活性剂、阴离子表面活性剂、除锈剂、溶剂。

用法用量: 在衣物洗涤前, 取适量本品先刷洗衣领等重污渍处。

注意事项: 本品需在常温下使用。

Use features: This product is proven to demonstrate a special effect on oil stains and protein. It is specially used for pre-washing the heavy dirt in local area, such as clothing collar, cuff and bag.

Ingredient characteristics: Nonionic surfactant, anionic surfactant, rust remover and solvent

Usage and dosage: Before washing the clothes, take this product in the appropriate amount to brush the collar and other heavy oil stains etc.

Note: This product shall be used at room temperature.

DFG014 干皂油

DRY CLEANING SOAP



SUPER CLEAN 品牌
Super-clean Brand



KIMBO 品牌
KIMBO Brand



深海洁品牌
Sea Clean Brand



驰丽洁品牌
ChiLiJie Brand

包装容量 Packing Capacition:3.8L/19L

用途特点: 本品为配合特效干洗剂使用的高浓度干洗油。可显著去除织物污垢, 增加织物的光泽和柔软, 保持织物纤维润泽, 防止纤维间静电的形成。

成分特性: 非离子表面活性剂、阴离子表面活性剂、醇醚、卤代烃。

用法用量: 推荐每 45~50kg 布草按 0.3%~0.5% 的比例, 将本品直接添加在特效干洗剂中使用。

注意事项: 避免触及眼睛, 若已接触, 立即用大量清水冲洗。切勿入口。使用时建议戴上防护手套。

Use features: This product is a dry cleaning soap with the high concentration and it can be matched with the special effect dry cleaner for using. It enables to significantly remove the dirt, increase the luster and softness of the fabric, keep smooth of fabric fiber and prevent static electricity from being formed among the fiber.

Ingredient characteristics: Nonionic surfactant, anionic surfactant, alcohol ether and halogenated hydrocarbons.

Usage and dosage: It is recommended that the product is directly added to the special effect dry cleaner for using in a proportion of 0.3%~0.5% per 45~50kg clothes.

Note: Avoid touching the eyes. In case of contact, rinse immediately with plenty of water. Never eating. It is suggested to wear protective gloves when using.

DFG015 消毒剂 (可高倍稀释) 粤卫消证字[2025]-01-第8037号

DISINFECTANT (WHICH CAN BE DILUTED FOR MANY TIMES)



SUPER CLEAN 品牌
Super-clean Brand



KIMBO 品牌
KIMBO Brand



深海洁品牌
Sea Clean Brand



驰丽洁品牌
ChiLiJie Brand

包装容量 Packing Capacition:3.8L/19L

用途特点: 本品为蓝色液体。采用阳离子化合物和二苯醚类化合物交叉和创新设计,对真菌有高效杀灭作用,甚至对芽孢也有杀灭效果。主要用于各类纺织物品、人体、各类工业设备、医院设备和家具表面的消毒和卫生清洁。可以清除衣物静电、柔软衣料,不会使衣物脱色

主要成分: 季铵盐、阳离子化合物、二苯醚类化合物、非离子表面活性剂、脂肪醇。

用法用量: 原液具有高效的生物活性,根据不同使用情况,可以用水稀释100~1000倍使用。

注意事项: 稀释使用,外用消毒剂禁止口服,置于儿童不易触及处。

Applications & Features: This product is blue liquid. It is designed on the basis of mixing and innovation of cationic compound and diphenyl ether compound. It can effectively kill funguses and even can kill gammae. It is mainly used to disinfect and clean the surfaces of various textile, human body, industrial equipment, hospital equipment and furniture. In addition, it can clean various dress materials but not de-color the clothes.

Main Compositions: Quaternary ammonium salt, cationic compound, diphenyl ether compound, non-ionic surfactant, fatty alcohol.

Usage & Dosage: The pure liquid possesses efficient biological activity and can be used after being diluted with water for 100-1000 times as per different purposes.

Considerations: This product should be used after being diluted. It is for external use, so it is prohibited to take it orally. In addition, it should be kept out of children's reach.



超洁亮专业清洁剂实验室
Research And Development Room

床单类洗涤程序

装载量约 50kg

序号	工序	洗涤条件			加入洗涤剂			检测及结果
		水位	温度 /°C	时间 / 分钟	名称	加入量 / 克	加入方法	
1	预洗	高	≈30	3	低温酵素	50-100		
2	主洗	低	70-80	8-10	软水剂	150-200	达到水位后加入	水硬度 < 100PPm PH = 10-12
					彩漂粉	500	加入水处理粉 1-2 分钟后 加入	
					增白彩漂 洗衣粉	350-400	60°C加入一半 4-5 分钟后 另一半	
3	中脱排水			3				
4	第一遍过水	高		3				
5	第二遍过水	高		2				
6	第三遍过水	高		2				
7	过酸中和	低		5	荧光中和酸	200	达到水位后加入	PH = 5-6
8	上浆	中	70-80	5	浆粉	400-500		
9	高脱排水			6-8				

毛巾类洗涤程序

装载量约 50kg

序号	工序	洗涤条件			加入洗涤剂			检测及结果
		水位	温度 /°C	时间 / 分钟	名称	加入量 / 克	加入方法	
1	预洗	高	≈30	3	低温酵素	50-100		
2	主洗	低	70-80	8-10	软水剂	150-200	达到水位后加入	水硬度 < 100PPm PH = 10-12
					彩漂粉	500	加入水处理粉 1-2 分钟后 加入	
					增白彩漂 洗衣粉	350-400		
3	中脱排水			3				
4	第一遍过水	高		3				
5	中脱排水			2				
6	第二遍过水	高		2				
7	中脱排水			1	荧光中和酸	200	达到水位后加入	PH = 5-6
8	过酸中和	低		3-5	柔顺剂	500-600	加入酸剂后加入	
9	柔软							
10	高脱排水			8				

衣物洗涤程序

装载量约 50kg

序号	工序	洗涤条件			加入洗涤剂			检测及结果
		水位	温度 /°C	时间 / 分钟	名称	加入量 / 克	加入方法	
1	预洗	高	≈ 30	3				
2	主洗	低	40-60	1-15	软水剂	150-200	达到水位后加入	水硬度 < 100PPm PH ≈ 10
					增白彩漂洗衣粉	400	加入水处理粉 1-2 分钟后加入	
					洗衣粉	400-600		
3	中脱排水			3				
4	第一遍过水	高		3				
5	中脱排水			1				
6	第二遍过水	高		3				
7	中脱排水			1				
8	第三遍过水	高		3				
9	中脱排水			1				
10	中和柔软	低	35-45	3-5	荧光中和酸 织物柔顺剂	200 450-500	达到水位后加入	Ph ≈ 5-6
11	高脱排水			8-8				

台布洗涤程序

装载量约 50kg

序号	工序	洗涤条件			加入洗涤剂			检测及结果
		水位	温度 /°C	时间 / 分钟	名称	加入量 / 克	加入方法	
1	预洗	中	30-40	3				
2	中脱排水			2				
3	主洗	低	85-90	15-20	软水剂	150-200	达到水位后加入	水硬度 < 100PPm PH ≈ 10
					油污乳化剂	250	加入水处理粉 1-2 分钟后加入	
					强力高飘洗衣粉	500	约 40°C加入	
4	排水							
5	漂洗	低	60-70	6-9				
6	中脱排水			2				
7	第一遍过水	高		3				
8	第二遍过水	高		3				
9	第三遍过水	高		3				
10	中脱排水			2				
11	过酸中和	低	35-40	6	荧光中和酸	200		Ph ≈ 5-6
12	上浆				浆粉	400-500	中和 2 分钟后加入	
13	高脱排水			6				

注：1、必须使用两倍量取或称取标准数量。 2、视具体污垢轻重加减量。 3、以表格用量为参考数据。

DFH001 自动洗碗碟机清洁剂

AUTOMATIC WASHING-UP MACHINE CLEANER



SUPER CLEAN 品牌
Super-clean Brand



KIMBO 品牌
KIMBO Brand



深海洁品牌
Sea Clean Brand



驰丽洁品牌
ChiLiJie Brand

包装容量 Packing Capacition:19L

用途特点: 本品是专为各类洗碗、碟机而设计的强力浓缩液体清洁剂。安全可靠，对水质无特别要求。

成分特性: 氢氧化钾、表面活性剂、缓蚀剂。

用法用量: 用本品 0.2%-2% 加入到清水中，配成洗碗液，用于洗碗机中洗碗。

水温加热至 60°C—70°C 之间洗涤效果更佳。

注意事项: 避免触及眼睛，若已接触，立即用大量清水冲洗。切勿入口。使用时建议戴上防护手套。

Use features: This product is a highly concentrated liquid cleaner specially designed for cleaning all kinds of dishes and bowls. Thanks to its safety and reliability, No special requirement is proposed for water quality.

Ingredient characteristics: Potassium hydroxide, surfactant and corrosion inhibitor.

Usage and dosage: Add 0.2%-2% of this product to the clear water to prepare a dishwashing liquid and then use it in the dishwasher. The washing effect is better if the water temperature is heated to 60°C—70°C.

Note: Avoid touching the eyes. In case of contact, rinse immediately with plenty of water. Never eating. It is suggested to wear protective gloves when using.

DFH002 自动洗碗碟机催干剂

AUTOMATIC WASHG-UP MACHINE DRYER



SUPER CLEAN 品牌
Super-clean Brand



KIMBO 品牌
KIMBO Brand



深海洁品牌
Sea Clean Brand



驰丽洁品牌
ChiLiJie Brand

包装容量 Packing Capacition:19L

用途特点: 本品为各类洗碗碟机使用的超浓缩液体催干剂，能促进器皿迅速干燥，不留斑点。安全可靠，适合任何材料餐具和洗碗碟机。

成分特性: 聚醚、葡萄糖酸钠、溶剂。

用法用量: 将本品按 0.001%-0.1% 的比例加入到洗碗液中，正常洗碗。洗碗液加热到 75°C—85°C 时催干效果最佳。

注意事项: 避免触及眼睛，若已接触，立即用大量清水冲洗。切勿入口。使用时建议戴上防护手套

Use features: This product is a super concentrated liquid catalyst used for washing various types of dishes and bowls. It enables to promote the rapid drying of utensils but not leave spots. Thanks to its safety and reliability, it is suitable for any tableware and dishwasher made of any materials.

Ingredient characteristics: Polyether, sodium hyaluronate and solvent.

Usage and dosage: The product is added to the dishwashing liquid in the proportion of 0.001%-0.1% for normal cleaning. The drying effect is the best if the water temperature is heated to 75°C—85°C.

Note: Avoid touching the eyes. In case of contact, rinse immediately with plenty of water. Never eating. It is suggested to wear protective gloves when using.

DFH004

炉灶清洁剂

COOKING RANGE CLEANER



SUPER CLEAN 品牌
Super-clean Brand



KIMBO 品牌
KIMBO Brand



深海洁品牌
Sea Clean Brand



驰丽洁品牌
ChiLiJie Brand

包装容量 Packing Capacition:3.8L/19L

用途特点: 本品是一种含有碱、溶剂和表面活性剂的低泡液体高效脱脂剂。专为清洁厨房及炉灶油腻污渍而设计,能清洁普通清洁剂所不能去除的坚硬油焦。

成分特性: 苛性碱、两性表面活性剂、溶剂。

用法用量: 推荐用量 3%~10%。

注意事项:

1. 必须紧锁盖口,存放在远离儿童的地方。
2. 使用中应戴防护用具,不接触皮肤、眼睛,不入口。
3. 如沾及眼睛,应立即使用大量清水冲洗。
4. 如沾及皮肤,应立即使用大量清水冲洗。
5. 遇到意外或感到不适时,应立即就医诊治。
6. 油漆或铝制表面禁用。

Use features: This product is low foam liquid and high efficiency degreasing agent,containing alkali, solvent and surfactant. It is specially designed for cleaning the kitchen and cooking oil stains, while it can clean the stubborn oil coke that can't be cleaned by the ordinary cleaner.

Ingredient characteristics: Caustic alkali, amphoteric surfactant and solvent.

Usage and dosage: It is recommended to use 3-10% of the product.

Note:

1. The cap must be tightened and the product shall be stored in the place away from the children.
2. Wear protective equipment when using. It shall not contact the skin and eyes. Never eating.
3. If it contacts eyes, rinse them immediately with plenty of water.
4. If it contacts skin, rinse them immediately with plenty of water.
5. If any accident or discomfort occurs, please consult doctors immediately.
6. It shall not be used for paint or aluminum surface.

DFH005

除垢清洁剂

DIRT CLEANER



SUPER CLEAN 品牌
Super-clean Brand



KIMBO 品牌
KIMBO Brand



深海洁品牌
Sea Clean Brand



驰丽洁品牌
ChiLiJie Brand

包装容量 Packing Capacition:3.8L/19L

用途特点: 本品是由多种复合酸复配而成的低泡除垢清洁剂。对含钙、铁、镁成份的积垢特别有效。适用自动洗碗碟机加热管、抽水泵的水垢清除,延长洗碗碟机使用寿命。他含有金属保护剂,使金属表面清光光亮。

成分特性: 非离子表面活性剂、磷酸等复合酸、缓蚀剂。

用法用量: 直接使用无需稀释。

注意事项: 避免触及皮肤及眼睛,若已接触,立即用大量清水冲洗。切勿入口。使用时建议戴上防护手套。对所洗物表面性质不明者,应先在不见的地方进行试验,如发现脱色、染色,则用清水过净,立即停止使用。

Use features: This product is a low foam dirt cleaner prepared by various compounded acids. It is proven to show a special effect on calcium, iron and magnesium fouling. It is suitable for removing incrustant in heating pipe and water pump in automatic dishwashing machine. Additionally, it can prolong the service life of the dishwashing machine. Because it contains metal protecting agent, the metal surface can be clean and bright.

Ingredient characteristics: Nonionic surfactant, phosphoric acid and other compound acids, corrosion inhibitor.

Usage and dosage: It can be directly used without dilution.

Note: Avoid touching the eyes. In case of contact, rinse immediately with plenty of water. Never eating. It is suggested to wear protective gloves when using. If the material nature of the washing surface is unknown, test the product in the hidden place. In case of bleaching and dyeing, wash it with water and immediately stop using.

DFH006 粉状炉灶清洁剂

POWDER COOKING RANGE CLEANER



SUPER CLEAN 品牌
Super-clean Brand



KIMBO 品牌
KIMBO Brand



深海洁品牌
Sea Clean Brand



驰丽洁品牌
ChiLiJie Brand

包装容量 Packing Capacition:20kg

用途特点: 本品是一种含碱性成份的粉状油垢清洁剂,对清除焦化油垢特别有效。能迅速消除火炉、烤炉、排气罩等物件的燃烧余积物,炭化油脂。

成分特性: 表面活性剂、硅酸钠、碳酸钠、软水剂、苛性碱。

用法用量: 使用时视污渍情况自行调节。

注意事项: 避免触及眼睛,若已接触,立即用大量清水冲洗。切勿入口。使用时建议戴上防护手套。

Use features:This product is oil dirt cleaner in a form of powder, containing alkali ingredient. It shows a special effect on removing coking oil dirt. It enables to quickly eliminate the burning residual and coked grease in furnace, oven, exhaust hood and other objects.

Ingredient characteristics:

Surfactant, sodium silicate, sodium carbonate, water softener and caustic alkali

Usage and dosage:The dosage is adjusted accordingly depending on the dirt when using.

Note:Avoid touching the eyes. In case of contact, rinse immediately with plenty of water. Never eating. It is suggested to wear protective gloves when using.

DFH007 浸银粉

SILVER DIP POWDER



SUPER CLEAN 品牌
Super-clean Brand



KIMBO 品牌
KIMBO Brand



深海洁品牌
Sea Clean Brand



驰丽洁品牌
ChiLiJie Brand

包装容量 Packing Capacition:20kg

用途特点: 本品适用于清洁银质及不锈钢餐具,具清洁及保护双重功能。消除银质餐具表面的硫化物或氧化物,令银质餐具回复其金属光浮,也可防止不锈钢表面斑点腐蚀。

成分特性: 表面清洁剂、还原剂。

用法用量: 在电解槽中,按每 100 公斤 500~1000g。

注意事项: 避免触及眼睛,若已接触,立即用大量清水冲洗。切勿入口。使用时建议戴上防护手套。

Use features:This product is suitable for cleaning silver and stainless steel tableware. It is proud of cleaning and protection functions. It enables to remove sulphide or oxide on the silver tableware surface and restore silver tableware to its metallic luster, while it can prevent corrosion and spots on the stainless steel surface.

Ingredient characteristics: Surface cleaner and reducing agent.

Usage and dosage: 500~1000g product is used per 100 kg tableware in the electrolytic tank.

Note: Avoid touching the eyes. In case of contact, rinse immediately with plenty of water. Never eating. It is suggested to wear protective gloves when using.

DFH008 浸渍粉

SOAK



SUPER CLEAN 品牌
Super-clean Brand



KIMBO 品牌
KIMBO Brand



深海洁品牌
Sea Clean Brand



驰丽洁品牌
ChiLiJie Brand

包装容量 Packing Capacition:20kg

用途特点: 本品为粉状物, 专门用于快速清除塑料、瓷碗碟及金属餐具表面上的污渍, 对碗碟无损害。

成分特性: 表面活性剂、过碳酸钠。

用法用量: 每升清水加入 6-12 克本品配成浸渍液, 将碗碟完全浸没 15~20 分钟后, 再用清水冲洗干净。将浸渍液加热到 60°C—70°C 去污效果更佳。

注意事项: 常温时延长浸没时间。

use Teatures:

This product, a powder, is specifically used for rapidly removing stains on plastic, porcelain bowls and dishes and metal tableware surface without damage.

Ingredientcharacteristics: Surfactant and sodium carbonate.

Usage and dosage: The product is prepared to be a soakage liquid by adding 6-12g product per 1 liter clear water. Dishes and bowls are completely soaked for 15~20 minutes and then rinse them with water. The detergency effect is better when soakage liquid is heated to 60°C—70°C.

Note: It shall extend immersion time at room temperature.

DFH009 通渠粉

POWDER FOR DREDGING



SUPER CLEAN 品牌
Super-clean Brand



KIMBO 品牌
KIMBO Brand



深海洁品牌
Sea Clean Brand



驰丽洁品牌
ChiLiJie Brand

包装容量 Packing Capacition:20kg

用途特点: 本品是一种粉状强碱性渠道疏通剂。适用于被食品残渣阻塞渠道的疏通。超浓缩、化学反应快、易溶、冲洗迅速彻底。

成分特性: 阴离子表面活性剂、苛性碱、硫酸钠。

用法用量: 每次推荐用量 300~500g。

注意事项: 避免触及眼睛, 若已接触, 立即用大量清水冲洗。切勿入口。

Use features: This product is a strong alkaline channel dredge powder. It is suitable for dredging the channel that is blocked by the food residue. It is characterized by super concentration, fast chemical reaction, easy dissolution and quick and thorough rinsing.

Ingredient characteristics: Anionic surfactant, caustic soda and sodium sulfate

Usage and dosage: 300~500g dosage is recommended each time.

Note: Avoid touching the eyes. In case of contact, rinse immediately with plenty of water. Never eating.

DFH011 除菌除味剂

STERILIZATION AND ODOUR-REMOVED AGENT



SUPER CLEAN 品牌
Super-clean Brand



KIMBO 品牌
KIMBO Brand



深海洁品牌
Sea Clean Brand



驰丽洁品牌
ChiLiJie Brand

包装容量 Packing Capacition:3.8L/19L

用途特点: 本品为一种多用途新型季胺化合物消毒剂。它含有水质调节剂、干燥剂以及除臭成份,具有多种功效。适用于卧室、储物室、浴室、厕所、冰箱、仓库、垃圾房等场所消除臭味,控制霉菌。

成分特性: 季胺盐、溶剂、香精。

用法用量: 建议每 1 00 公斤水中兑入 50g 本品。

注意事项:

1. 必须紧锁盖口及摆放在远离儿童的地方。
2. 使用中戴上适当的防护衣物,不触及皮肤和口、眼。
3. 如沾及皮肤和口、眼睛,应立即使用大量清水冲洗。如有不适立即就医。

Use features: This product is a new type and multi-purpose quaternary amine compound disinfectant. It contains water quality regulator, desiccant and deodorant ingredient and it is proud of a variety of effects. It is suitable for eliminating odor and controlling mold in the bedroom, storage room, bathroom, toilet, refrigerator, warehouse, garbage room and other places.

Ingredient characteristics: Quaternary amine salt, solvent and essence.

Usage and dosage: It is recommended that 50g product is added to per 100 kg water.

Note:

1. The cap must be tightened and the product shall be stored in the place away from the children.
2. Wear protective clothes when using. It shall not contact the skin, mouth and eyes.
3. If it contacts the skin, mouth and eyes, rinse them immediately with plenty of water. If any discomfort occurs, please consult doctors immediately.

DFH012 抗菌洗手液

DISINFECTING HAND SOAP

粤卫消证字[2025]-01-第8037号



SUPER CLEAN 品牌
Super-clean Brand



KIMBO 品牌
KIMBO Brand



深海洁品牌
Sea Clean Brand



驰丽洁品牌
ChiLiJie Brand

包装容量 Packing Capacition:3.8L/19L

用途特点: 本品是一种含有杀菌剂,手感温和的浓缩型液体消毒剂。能杀灭细菌、真菌、霉菌,适用于公共场所洗手消毒。他还含有润肤剂,保持手部湿润,防止干燥。

成分特性: 表面活性剂、羊毛脂、丙三醇、对氯二甲苯酚。

用法用量: 建议每次使用 1 0~20m L 本品。

注意事项: 皂液器要定期清洁消毒,避免皂液器细菌污染影响产品品质。

Use features: This product is a concentrated mild liquid disinfectant containing bactericide. It can kill bacteria, fungi and fungi, thus it is suitable for washing hands and disinfection in public places. Additionally, it also contains emollient that can keep your hands moist and prevent dry.

Ingredient characteristics: Surfactant, lanolin, propylene glycol, p-chlorodimethylphenol.

Usage and dosage: It is recommended to use 10~20mL product each time.

Note: The soap dispenser shall be regularly cleaned and disinfected so as to prevent the product quality from being affected by the soap dispenser bacterial contamination.

DFH013

金器清洁剂

COLDWARE CLEANER



SUPER CLEAN 品牌
Super-clean Brand



KIMBO 品牌
KIMBO Brand



深海洁品牌
Sea Clean Brand



驰丽洁品牌
ChiLiJie Brand

包装容量 Packing Capacition:3.8/19L

用途特点: 本品专用于清洗镀金餐具上的顽固污渍, 令已硫化暗淡的金质餐具回复原有光泽。

成分特性: 表面活性剂、磷酸复合酸、还原剂。

用法用量: 建议将本品按 10%~20% 的比例兑入清水中。漫没金器, 待 30~40 分钟后过清水。

注意事项: 避免触及眼睛, 若已接触, 立即用大量清水冲洗。切勿入口。使用时建议戴上防护手套。

Use features: This product is specially used to clean the stubborn dirt on the gilded tableware so as to make a vulcanized dark gold tableware restore the original luster.

Ingredient characteristics: Surfactant, phosphoric acid compound acid and reducing agent.

Usage and dosage: It is recommended that the product is mixed in the clear water in the proportion 10%~20%. Immerse the gilded tableware for 30-40 minutes and then rinse it with water.

Note: Avoid touching the eyes. In case of contact, rinse immediately with plenty of water. Never eating. It is suggested to wear protective gloves when using.

DFH014

强力化油清洁剂

POWER OIL CLEANER



SUPER CLEAN 品牌
Super-clean Brand



KIMBO 品牌
KIMBO Brand



深海洁品牌
Sea Clean Brand



驰丽洁品牌
ChiLiJie Brand

包装容量 Packing Capacition:3.8L/19L

用途特点: 本品为无色或微黄色, 有柠檬香味的清洁剂。适用于厨房内除油。对一切油污有强去污力。特别适用于各种烘炉、平板炉、炸炉、抽油烟机槽及隔网等除油清洁。能迅速渗透并乳化及皂化各种炭焦油污及食物渣滓, 使除油工作变得便捷。

成分特性: 非离子活性物、阴离子活性物、软水剂、丙二醇甲醚、香精。无色或微黄色、柠檬香。

用法用量: 普通污渍: 1份本品兑8倍清水, 或视乎污渍程度而调节。可用作喷洗、浸洗或刷洗。重油污渍: 直接将除油剂喷涂表面, 待5-10分钟, 用刷洗或喷洗方法去掉油污。

注意事项: 请勿与酸性清洁剂共用; 避免触及眼睛, 若已接触, 立即用大量清水冲洗。切勿入口。使用时建议戴上防护手套。

Use features: This product is colorless or yellowish and it is a degreaser with the lemon fragrance. It is suitable for removing greasy dirt in the kitchen. It shows the strong capability to remove all kinds of greasy dirt. It is especially suitable for removing and cleaning greasy dirt in various ovens, flat furnaces, blast furnaces, cooker hood groove and screen. It can quickly penetrate, emulsify various carbon coke oils and food waste and then make them saponification so that the oil removal work is convenient.

Ingredient characteristics: Nonionic surfactant, anionic surfactant, water softener, propylene glycol ether and flavor. It is colorless or yellowish and shows lemon fragrance.

Usage and dosage: Ordinary stains: the product is diluted by the clear water in the ratio of 1:8 or it is adjusted depending on the stains. It can be used in a form of spraying, rinsing or brushing. Heavy oil stains: the degreaser shall be directly sprayed to the surface. 5-10 minutes later, remove grease in a form of brushing or spraying.

Note: It can't be used together with acidic detergent; avoid touching the eyes. In case of contact, immediately rinse with plenty of water. Never eating. It is suggested to wear protective gloves when using.

DFH015 快速浸银水

SILVER DIP



SUPER CLEAN 品牌
Super-clean Brand



KIMBO 品牌
KIMBO Brand



深海洁品牌
Sea Clean Brand



驰丽洁品牌
ChiLiJie Brand

包装容量 Packing Capacition:3.8/19L

用途特点: 本品是一种银器污渍清洗剂,能快速消除氧化银锈,恢复银器的原有光泽。适用于一切中西镀银餐具器皿。

成分特性: 柠檬酸、还原剂、软水剂。

用法用量: 建议按 20%~30% 的比例兑入清水中,浸没银器 30 分钟后用清水。

注意事项: 避免触及眼睛,若已接触,立即用大量清水冲洗。切勿入口。使用时建议戴上防护手套。

Use features: This product is a silver stain cleaner. It enables to quickly remove the oxidized silver rust and restore silver to the original luster. It is suitable for all silver plated cutleries in Chinese and Western restaurants.

Ingredient characteristics: Citric acid, reducing agent and water softener.

Usage and dosage: It is recommended that the product is mixed in the clear water in the proportion 20%~30%. Immerse the silver cutleries for 30 minutes and then rinse it with water.

Note: Avoid touching the eyes. In case of contact, rinse immediately with plenty of water. Never eating. It is suggested to wear protective gloves when using.

DFH016 洗洁精

CLEANSER ESSENCE



SUPER CLEAN 品牌
Super-clean Brand



KIMBO 品牌
KIMBO Brand



深海洁品牌
Sea Clean Brand



驰丽洁品牌
ChiLiJie Brand

包装容量 Packing Capacition:3.8L/19L

用途特点: 本品由阴离子与非离子表面活性剂复配而成的无色粘稠透明液体、柠檬香型,融去污与抑菌功能为一体,去污迅速、泡沫适中、过水容易。

主要成分: 阴离子表面活性剂、非离子表面活性剂。

用法用量: 使用时滴三到五滴本品于常温水中即可。

注意事项: 避免触及眼睛,若已接触,立即用大量清水冲洗。

Applications& Features: This product is composed of anionic and nonionic sullactants, is a combination of decontamination and bacteriostasis function, quickly remove the dirty, foam is moderate, easy clean with water.

Main Compositions: Anionic surfactant, Nonionic surfactant.

Usage and Dosage: Three to five drops when using this product in water with normal temperature.

Considerations: Avoid touching the eyes. In case of contact, rinse immediately with plenty of water.

DFH017 84消毒液

粤卫消证字[2025]-01-第8037号
 DISINFECTANT



SUPER CLEAN 品牌
 Super-clean Brand



KIMBO 品牌
 KIMBO Brand



深海洁品牌
 Sea Clean Brand



新品小瓶装 NEW
 750mL

包装容量 Packing Capacition:3.8/19L

用途特点: 本品为略带浑浊的液体, 主要成分为次氯酸钠。主要用途消毒杀菌, 可杀灭肠道致病菌和化脓性球菌, 并能灭活病毒。

主要成分: 次氯酸钠、表面活性剂和增效剂、稳定剂等。

注意事项: 切勿用于丝绸、毛、尼龙、皮革、油漆表面; 勿用于铝、铜、碳钢制品, 适用于不锈钢器具消毒; 本品只可用于白色织物, 使用时请先稀释后在隐蔽处试用, 勿直接使用原液浸洗; 勿与酸性清洁产品(如洁厕剂、酸性清洁剂、浴室清洁剂)混用; 餐饮具、瓜果蔬菜消毒后, 需用清水洗净; 建议使用时戴上防护手套, 避免接触皮肤和眼睛; 本品须避光、避热, 置于阴暗处保存; 外用消毒液, 禁止口服, 置于儿童不易触及处。

Applications& Features: This product is a little muddy liquid, and its main composition is sodium hypochlorite. It is mainly used for disinfection and sterilization. It can kill pathogenic enteric bacteria and pyogenic cocci as well as inactivate viruses.

Main Compositions: Sodium hypochlorite, surfactant, synergist, stabilizer, etc.

Considerations:

1. Do not use it for surfaces of silk, woolsens, nylon, leather and paint.
2. Do not use it for aluminum, copper and carbon steel products. It is applicable to disinfection of stainless steel utensils.
3. This product can be used for white textile. Please first dilute it and then try it at an inconspicuous position if you want to use it. Please do not directly use the pure liquid to soak the white textile.
4. Please mix this product with acidic cleaning supplies (such as toilet cleanser, acidic cleanser and bathroom cleanser).
5. Please use clean water to wash the food and beverage utensils as well as melons, fruits and vegetables after disinfecting them.
6. You are suggested wearing protective gloves when using this product to prevent your skin and eyes from contacting it.
7. Please keep this product in a dark place without light or heat.
8. The disinfectant is for external use, so it is prohibited to take it orally. In addition, it should be kept out of children's reach.

用法用量 USAGE AND DOSAGE

消毒对象 Disinfection Target		有效氯浓度 Concentration of Effective Chlorine	稀释比例 Dilution Rate	消毒方法 Disinfecting Method	作用时间 Action Time
			原液: 水 Pure Liquid VS Water		
食品接触用 Food	食饮具 瓜果蔬菜 Food & beverage utensils Melons, fruits, vegetables	900	1:15	浸泡擦拭后用水冲洗 Rinse the objects with water after soaking and scrubbing them	20 分钟 20 minutes
		300	1:49		20 分钟 20 minutes
一般物体表面和公众场所环境 Surfaces of ordinary objects and environments of public places		300	1:49	擦洗 Scrub	20 分钟 20 minutes
织物 Textile		300	1:49	浸洗 Soak rinse	20 分钟 20 minutes

品种 Varieties	页码 Page number	品种 Varieties	页码 Page number
--------------	----------------	--------------	----------------

PA清洁剂系列 PA General Cleaner

DFF001 特光超级蜡水 (免抛蜡) HIGH SPEED FLOOR FINISH	152
DFF002 高速面蜡 FLOOR FINISH	
DFF003 清洁磨光蜡 HIGH CLEAN FLOOR POLISH	153
DFF004 封地底蜡 ACRYLIC SEALER	
DFF005 柠檬家私蜡 LEMON FURNITURE WAX	154
DFF006 除油剂 DEGREASER	
DFF007 高泡地毯清洁剂 CARPET SHAMPOO-HIGH FOAM	155
DFF008 低泡地毯清洁剂 LOW FOAM CARPET CLEANER	
DFF009 地毯起渍剂 CARPET STAIN CLEANER	156
DFF011 全能清洁剂 (碱性配方) MUI TI-PURPOSE CLEANER (ALKALINE)	157
DFF011 全能清洁剂 (中性配方) GENERAL PURPOSE CLEANER (NEUTRAL)	
DFF012 化泡剂 ANTI-FOAM	158
DFF013 起蜡水 STRIPER	
DFF014 [消]中性消毒剂(绿水) GENERAL PURPOSE CLEANER (NEUTRAL ANTIBACTERIAL CLEANER)	159
DFF015 洗石水 STONE CLEANER	
DFF016 空气清新剂 AIR FRESHENER	160
DFF017 铝品光亮剂 ALUMINUM CLEANER	
DFF018 特效洁厕剂 TOILET CLEANER	161
DFF019 酸性清洁剂 ACIDIC CLEANER	
DFF020 静电吸尘剂 ELECTROSTATIC PRECIPITATOR	162
DFF021 不锈钢保养剂 STAINLESS STEEL CLEANER	
DFF022 玻璃清洁剂 GLASS CLEANER	163
DFF023 强力外墙清洁剂 STRONG-EFFECT WALL CLEANER	
DFF024 浴室清洁剂 BATHROOM CLEANER	164
DFF026 除胶剂 REMOVER	
DFF027 [消]浴室消毒剂 BATHROOM DISINFECTING CLEANER	165
DFF028 干泡地毯清洁剂 DRY FOAM RUG SHAMPOO	165

洗衣房清洁剂系列 Laundry Detergent Series

DFG001 强力高漂洗衣粉 STRONG DETERGENT POWDER	166
DFG002 增白彩漂洗衣粉 COMMON DETERGENT POWDER	

DFG003 低温酵素洗衣粉 FERMENT DETERGENT POWDER	167
DFG004 氯漂粉 BLEACH POWDER	
DFG005 彩漂粉 OXYGEN BLEACH POWDER	168
DFG006 浆粉 STARCH	
DFG007 除锈酸 RUST REMOVER/ACID	169
DFG008 荧光中和酸 FLUORESCENT/ACID	
DFG009 油污乳化剂 STAINS EMULSIFIER	170
DFG010 织物柔顺剂 FABRIC SOFTENER	
DFG011 丝毛洗涤剂 SILK&WOOL DETERGENT	171
DFG012 软水剂 WATER SOFTENER	
DFG013 衣领净 (预去斑剂) PRE-DETERGENT	172
DFG014 干皂油 DRY CLEANING SOAP	
DFG015 [消]消毒剂 (可高倍稀释) DISINFECTANT (WHICH CAN BE DILUTED FOR MANY TIMES)	173

厨房清洁剂系列 Kitchen Cleaning Detergent Series

DFH001 自动洗碗机清洁剂 AUTOMATIC WASHING-UP MACHINE CLEANER	176
DFH002 自动洗碗碟机催干剂 AUTOMATIC WASHING-UP MACHINE DRYER	
DFH004 炉灶清洁剂 COOKING RANGE CLEANER	177
DFH005 除垢清洁剂 DIRT CLEANER	
DFH006 粉状炉灶清洁剂 POWDER COOKING RANGE CLEANER	178
DFH007 浸银粉 SILVER DIP POWDER	
DFH008 浸渍粉 SOAK	179
DFH009 通渠粉 POWDER FOR DREDGING	
DFH011 除菌除味剂 STERILIZATION AND ODOUR-REMOVED AGENT	180
DFH012 [消]抗菌洗手液 DISINFECTING HAND SOAP	
DFH013 金器清洁剂 COLDWARE CLEANER	181
DFH014 强力化油清洁剂 POWER OIL CLEANER	
DFH015 快速浸银水 SILVER DIP	182
DFH016 洗洁精 CLEANSER ESSENCE	
DFH017 [消]84消毒液 DISINFECTANT	183



SUPER·CLEAN
超洁亮

要选好质量，还是超洁亮

